

# PHILIPS

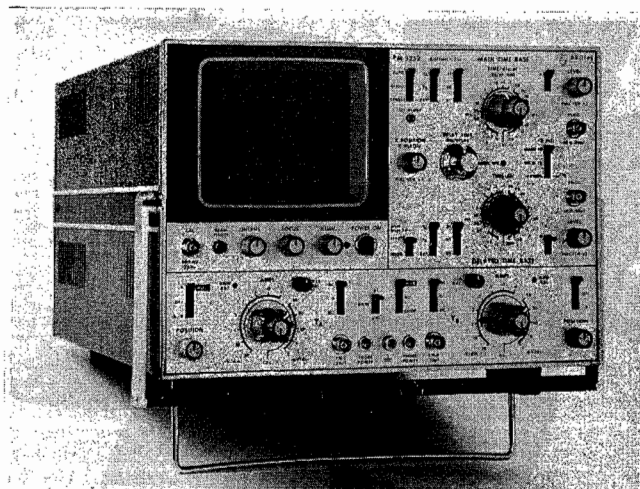

## Anleitung

(siehe auch Anleitung PM 3250)

HF-Multiplikator-Oszillograf **PM 3252**

(9444 032 52..1)

# Inhaltsverzeichnis

<b>1. ALLGEMEINE ANGABEN</b>	<b>3</b>
1.1. Einleitung	3
1.2. Technische Daten	4
1.3. Beschreibung des Blockschaltbildes	6
1.4. Verzeichnis von Multiplikatorausdrücken	10
<b>2. GEBRAUCHSANWEISUNG</b>	<b>15</b>
2.1. Bedienungsanleitung	15
<b>3. KUNDENDIENSTINFORMATIONEN</b>	<b>18</b>
3.1. Schaltungsbeschreibung	18
3.2. Prüfen und Einstellen	21
3.3. Einzelteilliste	26
<b>ABBILDUNGEN</b>	
1.2.1. Typische Frequenzkennlinie bei Multiplikatorbetrieb	5
1.3.1. Blockschaltbild	8
2.1.1. Bedienungsorgane an der Vorderseite	16
2.1.2. Rückseite des Gerätes mit Ausgang AxB	16
3.1.1. Prinzipschaltung des Multiplikators	18
3.1.2. Vereinfachtes Schaltbild des Multiplikators im PM 3252	19
3.2.1. Empfohlene Messgeräte	21
3.2.2. Lage des Transistors TS313 (TS113) im Vorverstärker	22
3.2.3. Einstellorgane der Multiplikatorplatte	22
3.2.4. Stellung "AUGENBLICKSWERT" der Drahtbrücken SK 2201/SK 2202	23
3.2.5. Stellung "MITTELWERT" der Drahtbrücken SK 2201/SK 2202	23
3.3.1. Frontansicht, Ausschnitt	26
3.4.1. Leiterplatte des Multiplikators, Einheit 45	30
3.4.2. Schaltbild des Multiplikators	32

# 1. ALLGEMEINE ANGABEN

## 1.1. Einleitung

Der PM 3252 ist ein 50-MHz-Zweikanaloszillograf mit eingebautem HF-Multiplikator, mit dem das Produkt von 2 Signalen auf dem Schirm der Elektronenstrahlröhre dargestellt werden kann.

Dieses Produktsignal  $Y_A \times Y_B$  kann zugleich mit dem Signal an Eingang  $Y_B$ , entweder in Abhängigkeit von der Zeit oder in Abhängigkeit vom Signal an Eingang  $Y_B$ , aufgezeichnet werden.

Dieser Oszillograf besitzt alle Messmöglichkeiten und Daten des 50-MHz-Oszillografen PM 3250, nur im Multiplikatorbetrieb ist die Bandbreite auf 40 MHz reduziert.

Ein weiteres besonderes Merkmal des PM 3252: Das Produktsignal kann an einem BNC-Konnektor an der Rückseite des Gerätes abgenommen werden. Man kann zwischen dem Augenblickswert und dem Mittelwert des angezeigten Produkts wählen.

Mit Hilfe dieses Ausgangs können die Messwerte auch auf einem Voltmeter oder Schreiber registriert oder einer Datenverarbeitungsanlage zugeführt werden. Ein Gleichspannungs-Voltmeter ist dann ein den Mittelwert anzeigendes Wattmeter.

## 1.2. Technische Daten

Zahlenwerte mit Toleranzangabe werden bei nominaler Netzspannung garantiert. Zahlenwerte ohne Toleranzangabe sind nur zur Information und geben die Eigenschaften eines durchschnittlichen Gerätes an.

Es folgen hier nur die Daten des Multiplikatorteils des PM 3252.

Die hier nicht aufgeführten Daten sind den Unterlagen des PM 3250 zu entnehmen.

Folgende technische Daten gelten nach einer Anwärmzeit von 30 min und bei einer Umgebungstemperatur von 23 °C, sofern nicht anders angegeben.

1.2.1.	Darstellungsmöglichkeiten des Multiplikators	Nur das Produkt (Signal A x Signal B) Das Produkt (Signal A x Signal B) und Signal $\pm B$ geschaltet mit 1 MHz Das Produkt (Signal A x Signal B) in Y-Richtung und Signal B in X-Richtung
1.2.2.	Bandbreite des Multiplikators	40 MHz (-3 dB) 35 MHz (-3 dB), in dem gesamten Temperaturbereich von 0 - 40 °C. Typische Frequenzkennlinie im Multiplikatorbetrieb siehe in Abb. 1.2.1. (Gemessen mit einem Sinussignal im einen und einer Gleichspannung im anderen Kanal)
1.2.3.	Anstiegszeit des Multiplikators	$\leq 9$ ns $\leq 10$ ns im gesamten Temperaturbereich von 0 - 40 °C
1.2.4.	Masstabfaktor	$1 \pm 2$ % (Temperaturkoeffizient 0,1 %/°C) (Das Produkt eines Signals A an Eingang $Y_A$ und eines Signals B an Eingang $Y_B$ wird in linearem Masstab, bezogen auf die Eingangssignale, mit einer Fehlergrenze von 2 % auf dem Schirm abgebildet).
1.2.5.	Dynamischer Bereich des Multiplikators	Signal A max. 8 Teile Spitze-Spitze ( $\pm 4$ Teile ab Schirmmitte) Signal B max. 8 Teile Spitze-Spitze ( $\pm 4$ Teile ab Schirmmitte) Produkt AxB 8 Teile Spitze-Spitze ( $\pm 4$ Teile ab Schirmmitte)
1.2.6.	Linearitätsfehler	max. 4 % der Schirmhöhe ( $\pm 0,16$ Teile) (Der Linearitätsfehler ist die Abweichung, gemessen als Spitzenwert, von $(AxB) = f(B)$ von einer idealen Geraden, gemessen mit 1000 Hz).
1.2.7.	Übersprechen	$\leq 0,2$ Teile (-32 dB) (Unerwünschtes Produkt, wenn ein Signal = Null und das andere Signal ein Sinussignal von 8 Schirmteilen ist).
1.2.8.	Produktverschiebung (off-set)	$\leq 0,2$ Teile bei 23 °C (Verschiebung der Nulllinie beim Umschalten von ALT oder CHOP. nach MULT.)
1.2.9.	Drift der Produktverschiebung	$\leq 0,03$ Teile/°C
1.2.10.	Fortpflanzungsverzögerung	Die Verzögerung zwischen dem Produkt und einem seiner Faktoren beträgt 8 ns.
1.2.11.	Ausgang AxB Art des Anschlusses Masstabfaktor  Ausgangspegel Ausgangsdrift	BNC an der Rückseite des Gerätes 100 mV $\pm 2$ % an $\geq 10$ k $\Omega$ für jeden auf dem Schirm dargestellten Teil des Produkts. 50 mV $\pm 2$ % an 50 $\Omega$ für jeden auf dem Schirm dargestellten Teil des Produkts 0 V $\pm 10$ mV bei 23 °C $\leq 3$ mV/°C an $\geq 10$ k $\Omega$ (1,5 mV/°C and 50 $\Omega$ )

Zeitkonstante  
(durch Drahtbrücke auf der  
Multiplikator-Leiterplatte wählbar)

1. Augenblickswert des Produkts
2. Mittelwert des Produkts; Integrationszeitkonstante ca. 100 ms

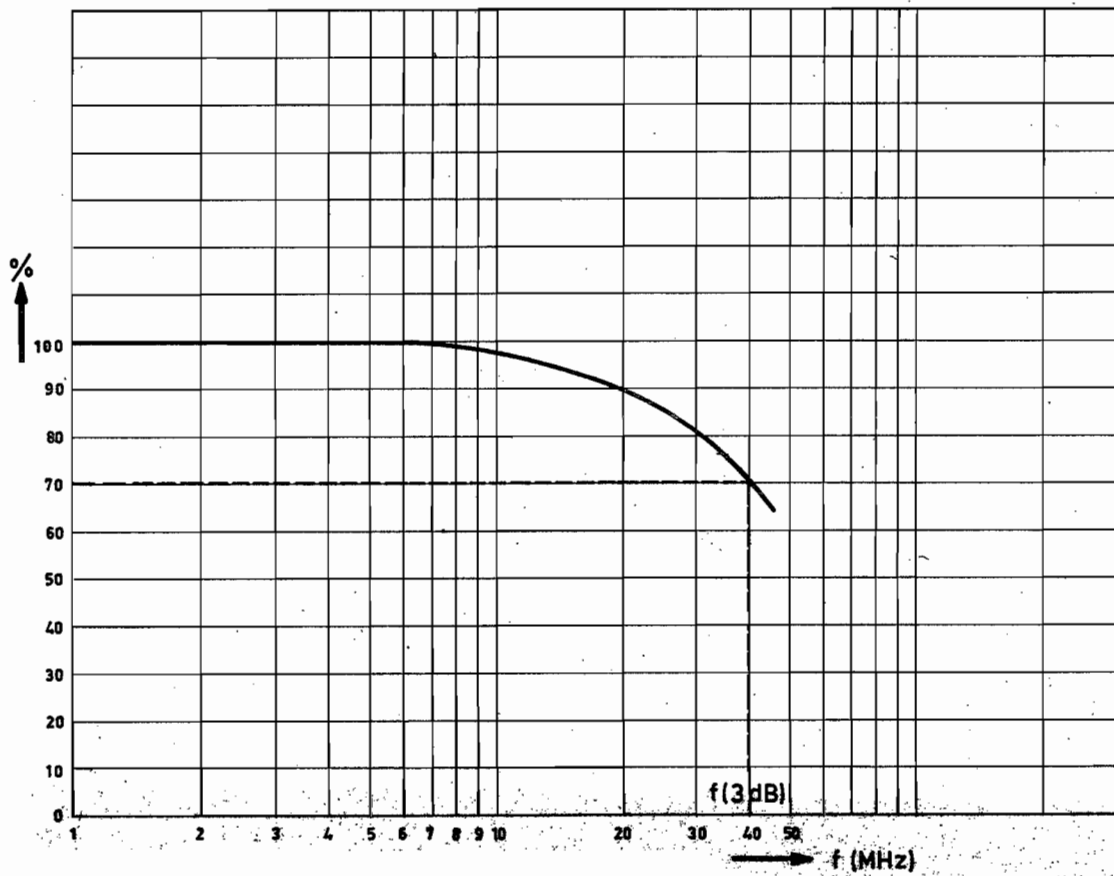

MA7905

Abb. 1.2.1. Typische Frequenzkennlinie bei Multiplikatorbetrieb

### 1.3. Beschreibung des Blockschaltbildes

In dieser Beschreibung wird der Multiplikator des PM 3252 beschrieben, der sich in dem roten Rechteck befindet (siehe Abb. 1.3.1.). Die in diesem Blockschaltbild nicht angegebenen Teile wurden bereits beim PM 3250 beschrieben (Kapitel IV).

Zum Einschalten des Multiplikators des Oszilloskops ist Schalter A (MULT)/OFF/A–B in Stellung A (MULT) und Schalter AxB/ALT/CHOP in Stellung AxB zu stellen.

Die für den Multiplikator benötigten Signale werden hinter dem Vorverstärker abgenommen.

Vor dem Multiplizieren kommt Signal A an einen Phasenspalter und Signal B an einen Spannungs-Strom-Wandler.

In diesen Stufen werden die Verschiebespannungen am Eingang des Multiplikators mit den Potentiometern 0xB (R21) und 0xA (R22), an der Vorderseite des Geräts kompensiert.

Der Multiplikator ist ein Vier-Quadrantentyp und arbeitet nach dem Prinzip der veränderlichen Steilheit.

Das Produktsignal läuft anschliessend durch einen Differentialverstärker, in dem es auf den erforderlichen Pegel verstärkt wird.

Dann kommt das Signal über eine Pufferstufe an den Zwischenverstärker.

Ausserdem kommt das Produktsignal über eine Pufferstufe an die BNC-Buchse (BU13) an der Rückseite des Geräts. Hierbei kann das Signal entweder direkt vom Differenzverstärker zur Pufferstufe geführt werden, dann steht an der Buchse der Augenblickswert zur Verfügung, oder über einen Integrator, so dass der Mittelwert des Produkts abgegeben wird.

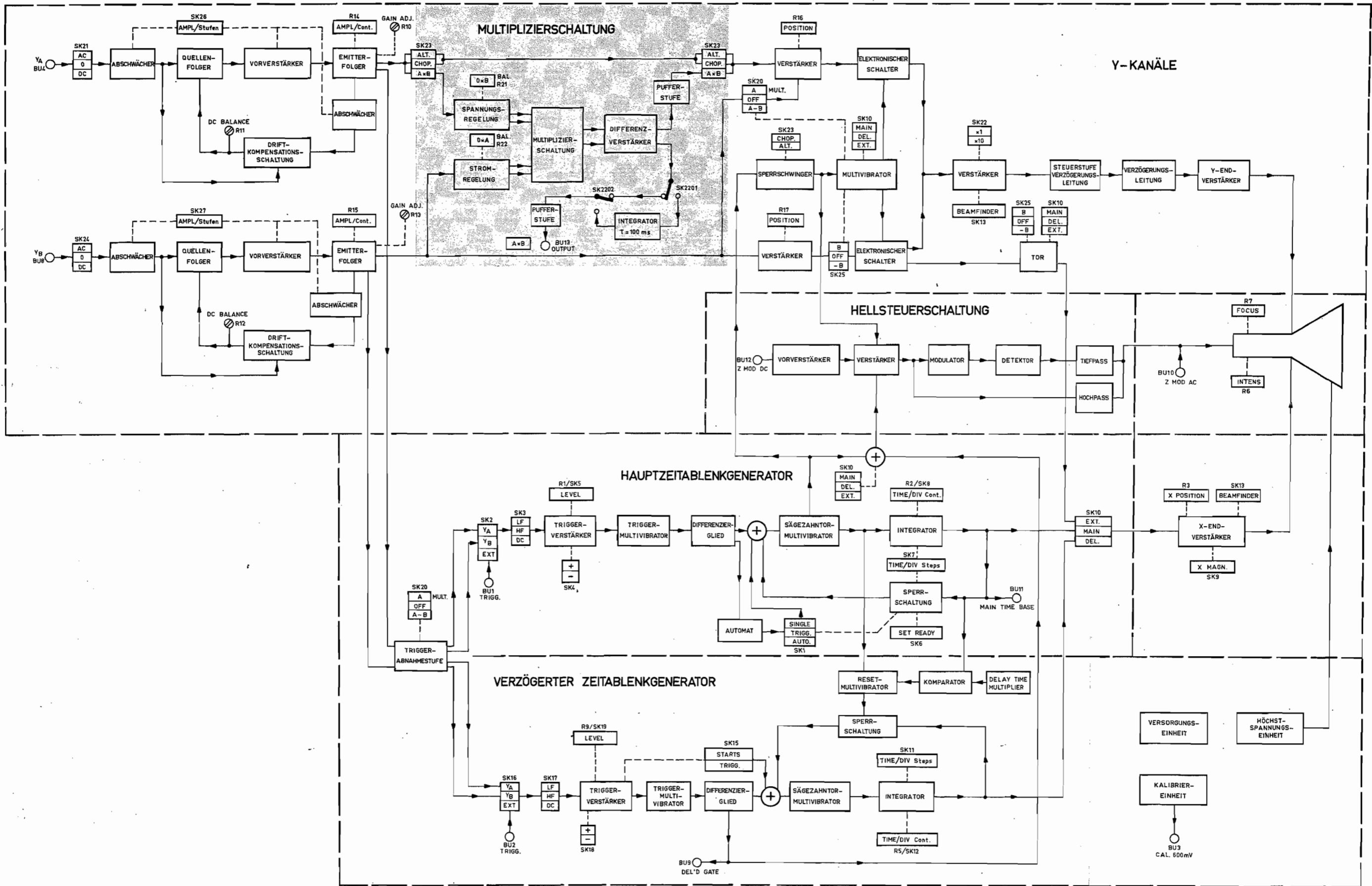

MA7736D

Abb. 1.3.1. Blockschaltbild

## 1.4. Verzeichnis von Multiplikatordrucken

### 1.4.1. Analoger Multiplikator

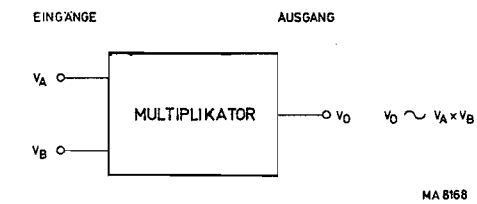

Ein analoger Multiplikator ist eine nichtlineare Vorrichtung, die eine Ausgangsspannung abgibt, die dem algebraischen Produkt von zwei Eingangsspannungen proportional ist.

### 1.4.2. Bandbreite des Multiplikators

Die Bandbreite des Multiplikators ist der Frequenzbereich zwischen Null und der Frequenz, bei der die Ausgangsspannung des Multiplikators um 3 dB gegenüber der Ausgangsspannung bei tiefen Frequenzen abgefallen ist. Diese Amplitude wird spezifiziert bei einer konstanten Sinusamplitude mit veränderlicher Frequenz an einem Eingang und einer Gleichspannung am anderen.

### 1.4.3. Anstiegszeit des Multiplikators

Die Anstiegszeit des Multiplikators ist die Ansprechzeit der Ausgangsamplitude, wenn an einen Eingang eine Sprungfunktion und an den anderen eine Gleichspannung angeschlossen wird. Diese Zeit wird zwischen den 10 %- und 90 %-Punkten der Sprungfunktion gemessen.

### 1.4.4. Vier-Quadrantenbetrieb

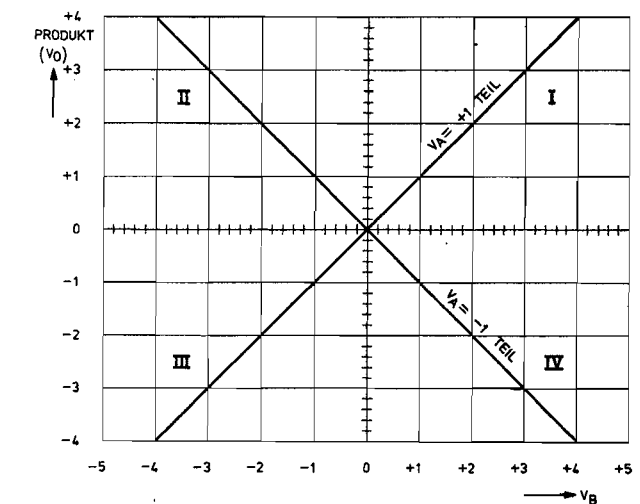
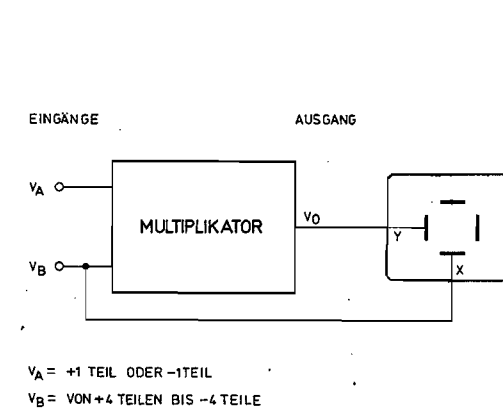

MA8150

Ein Vier-Quadranten-Multiplikator kann in jedem der vier Quadranten I bis IV des kartesischen Koordinatensystems ein Ausgangssignal liefern.



1.4.5. Eingangsverschiebung (off-set)

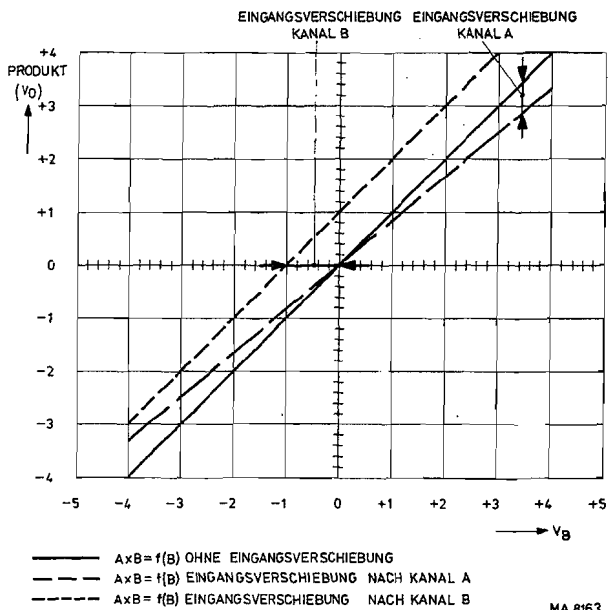
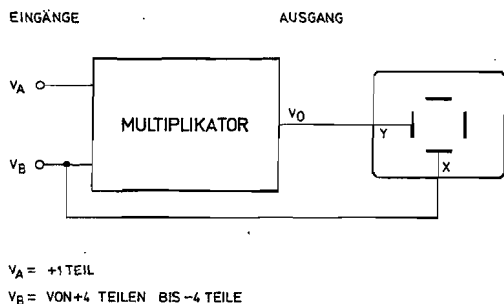

Die Eingangsverschiebung ist die tatsächliche Spannung am Eingang des Multiplikators, wenn kein Eingangssignal anliegt. Dieser Spannung kann durch eine Gleichspannungssymmetrierung entgegengewirkt werden.

1.4.6. Ausgangsverschiebung (off-set)

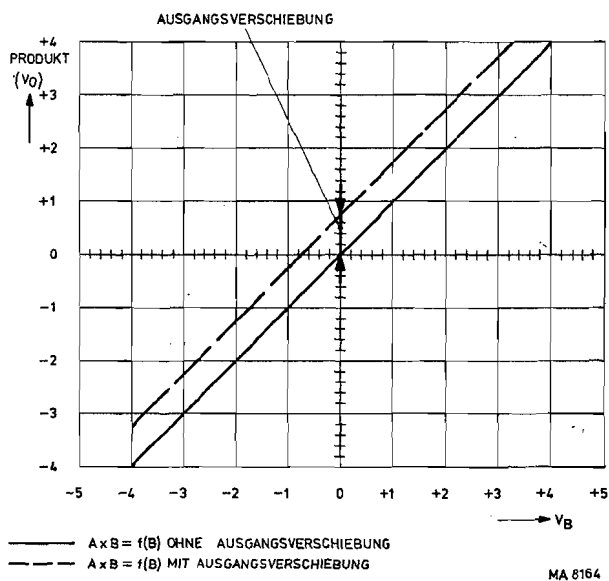
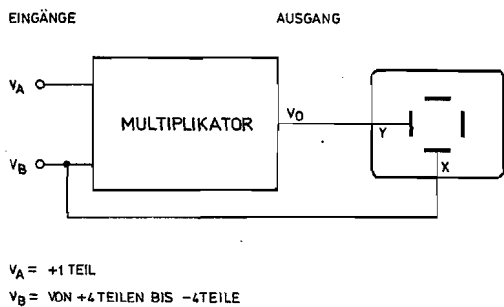

Die Verschiebung der Ausgangsspannung ist die unerwünschte Spannung am Ausgang des Multiplikators, wenn beide Eingangssignale Null sind. Diese Spannung ist als Vertikalverschiebung des Produkts sichtbar.

1.4.7. Masstabfaktor

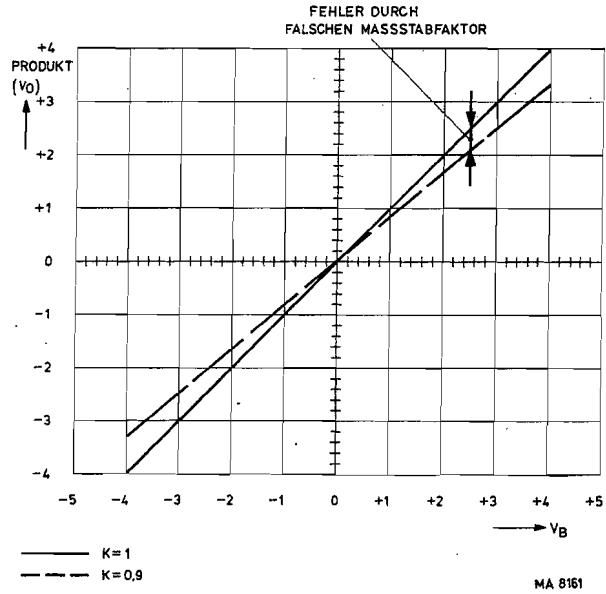
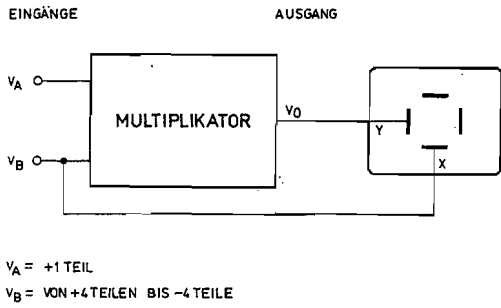

Der Masstabfaktor K ist die Proportionalitätskonstante, die das Verhältnis der Ablenkung der Elektronenstrahlröhre zu den Spannungen an den Eingängen A und B im Multiplikatorbetrieb angibt.

1.4.8. Linearitätsfehler

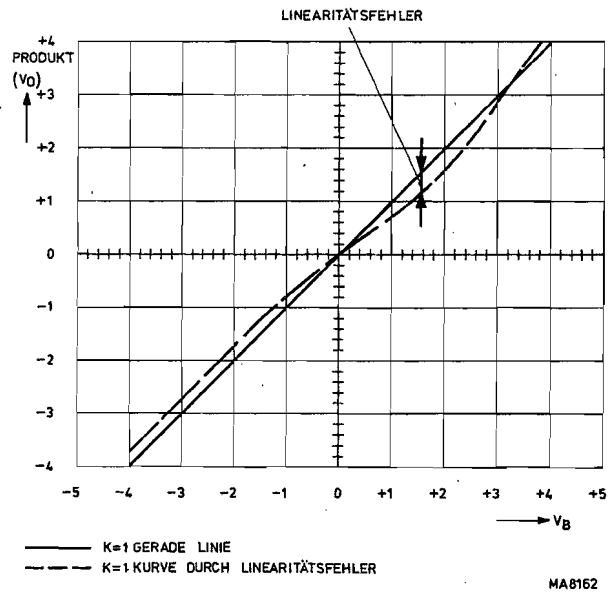
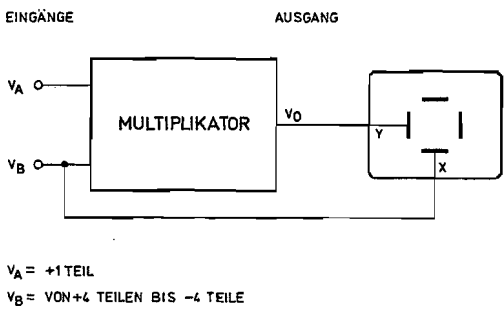

Der Linearitätsfehler ist die Abweichung, gemessen als Spitzenwert, von  $(A \times B) = f(B)$  von einer idealen Geraden. Er wird als Prozentsatz der Schirmhöhe angegeben.

1.4.9. Übersprechen

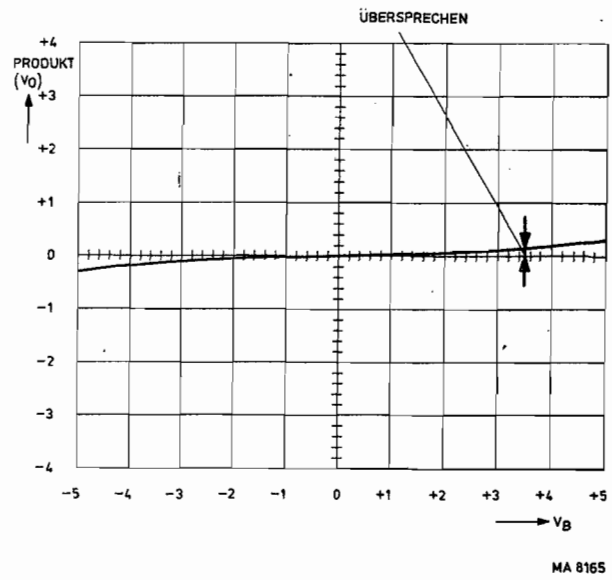
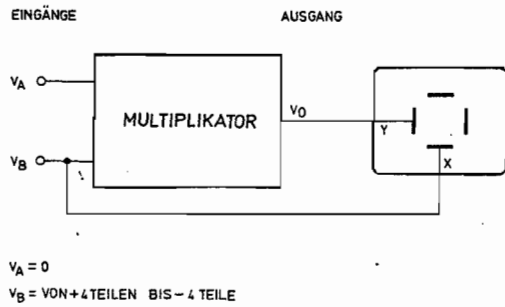

Das Übersprechen ist diejenige Wechselfspannung am Ausgang des Multiplikators, die nach Symmetrierung der Eingangsverschiebung gemessen wird, wenn ein Eingang auf Null gehalten und an den anderen ein maximales Signal angeschlossen wird.

1.4.10. Fortpflanzungsverzögerung

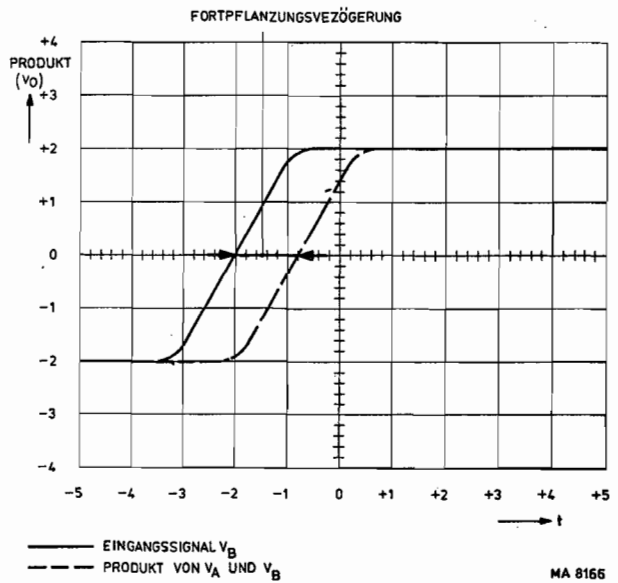
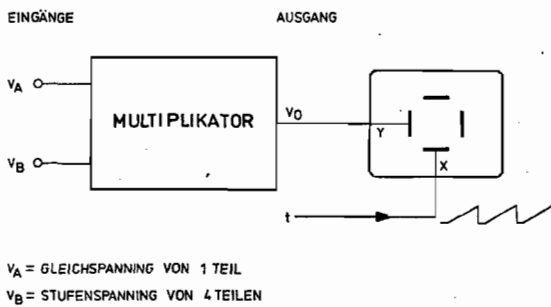

Die Fortpflanzungsverzögerung ist die Verzögerung zwischen den Eingangssignalen und dem Ausgangssignal, die durch die Verarbeitung der Eingangssignale im Multiplikator bedingt ist.

### 1.4.11. Rauschen

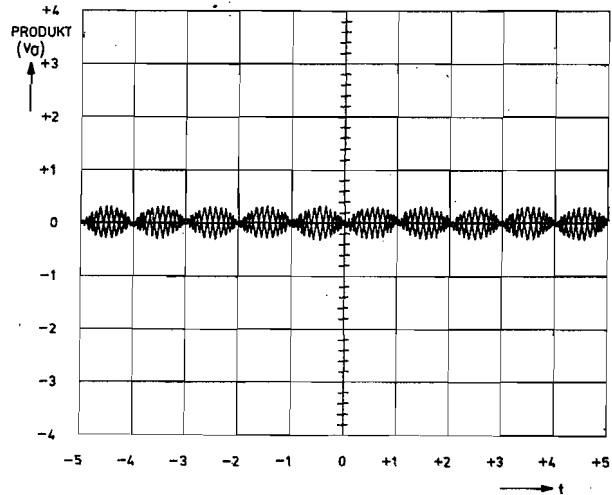
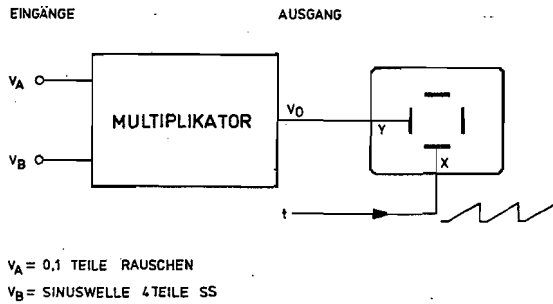

MA 8167

Der Multiplikator erzeugt kein nennenswertes Rauschen. Eine Eingangsspannung von A Teilen des einen Kanals multipliziert sich jedoch mit einem am Eingang des anderen Kanals liegenden Rauschen. Hierdurch kann eine Modulation gebildet werden, die als wellige Nulllinie erscheint.

### 1.4.12. Dynamischer Bereich des Eingangs

Das maximale Signal, das den Eingängen A und B zugeführt werden kann, ohne dass die Linearität beeinträchtigt wird.

### 1.4.13. Dynamischer Bereich des Ausgangs

Das maximale Signal am Ausgang, das noch linear wiedergegeben wird.

## 2. GEBRAUCHSANWEISUNG

### 2.1. Bedienungsanleitung

Für die allgemeinen Einstellungen gilt die Bedienungsanleitung des Grundgeräts PM 3250. Hier werden lediglich die den Multiplikator betreffenden Einstellungen beschrieben.

#### 2.1.1. Dynamischer Bereich

Beide Faktoren  $Y_A$  und  $Y_B$  müssen im dynamischen Bereich des Multiplikators und der Vorverstärker liegen. Da eine Übersteuerung dieser Schaltungen nicht ohne weiteres im Produkt zu erkennen ist, ist sehr darauf zu achten, dass jedes Eingangssignal innerhalb des spezifizierten dynamischen Bereichs liegt, d.h., dass die Amplitude maximal 8 Teile beträgt.

Für das dargestellte Produkt gilt wiederum eine maximale Amplitude von 8 Teilen. Wenn das maximal zulässige Ausgangssignal überschritten wird, muss die Amplitude von einem der Eingangssignale herabgesetzt werden.

#### 2.1.2. Symmetrierung des Multiplikators

Wenn entweder  $Y_A$  oder  $Y_B$  mit Null multipliziert wird, muss das Ergebnis ebenfalls Null sein. Durch Verschiebepotentialen an den Eingängen des Multiplikators kann jedoch auf dem Schirm eine gewisse Ablenkung auftreten. Diese Verschiebepotentialen lassen sich wie folgt auf ein Minimum herabsetzen:

- Das Gerät mindestens 15 Minuten, besser noch 30 Minuten, vorwärmen lassen.
- An Eingang  $Y_A$  und Eingang  $Y_B$  eine Wechselspannung anschliessen, deren Amplitude im spezifizierten dynamischen Bereich liegt.
- Folgende Bedienungsorgane einstellen:  
Schalter AxB/ALT/CHOP auf AxB  
Schalter A (MULT)/OFF/A–B auf A (MULT)  
Schalter AC/0/DC von Kanal A auf 0  
Schalter AC/0/DC von Kanal B auf AC  
Schalter GAIN auf x1.
- Mit Potentiometer OxB BAL minimale Ablenkung einstellen, ohne dabei die Einstellung des Abschwächers zu ändern.
- Schalter AC/0/DC von Kanal A auf AC stellen.
- Schalter AC/0/DC von Kanal B auf 0 stellen.
- Mit Potentiometer OxA BAL minimale Ablenkung einstellen, ohne den Abschwächer zu ändern.
- Schalter AC/0/DC von Kanal B zurück auf AC stellen; das Gerät ist nun betriebsbereit.

#### 2.1.3. Ausgangspegel des Multiplikators

Wie im Blockschaltbild gezeigt, erscheint das Ausgangssignal des Multiplikators auf Kanal A. Deshalb muss der Schalter A (MULT)/OFF/A–B immer in Stellung A (MULT) stehen, wenn der Oszilloskop als Multiplikator arbeitet. Das abgebildete Produkt enthält normalerweise eine Gleichspannungskomponente, auch wenn beide Eingangssignale Wechselspannungen sind. Deshalb muss der Nullpegel des abgebildeten Produkts unbedingt bekannt sein. Wenn einer der Schalter AC/0/DC auf 0 gestellt wird, kann die Gleichspannungs-Nulllinie mit der Strahlverschiebung von Kanal A in die günstigste Stellung geschoben werden.

#### 2.1.4. Ausgangsbuchse des Multiplikators

Das Ausgangssignal des Multiplikators liegt an einem BNC-Konnektor an der Rückseite des Geräts. Je nach Stellung der beiden Drahtbrücken auf der Multiplikator-Leiterplatte kann entweder der Augenblickswert oder der Mittelwert abgenommen werden.

Das Ausgangssignal hängt direkt von der Ablenkung der Elektronenstrahlröhre ab: Ein Teil entspricht 100 mV bei einer hochohmigen Belastung ( $\geq 10 \text{ k}\Omega$ ) oder 50 mV an  $50 \Omega$ .



Abb. 2.1.1. Bedienungsorgane an der Vorderseite



Abb. 2.1.2. Rückseite des Gerätes mit Ausgang AxB

### 3. KUNDENDIENSTINFORMATIONEN (Schaltbild, Abb. 3.4.2.)

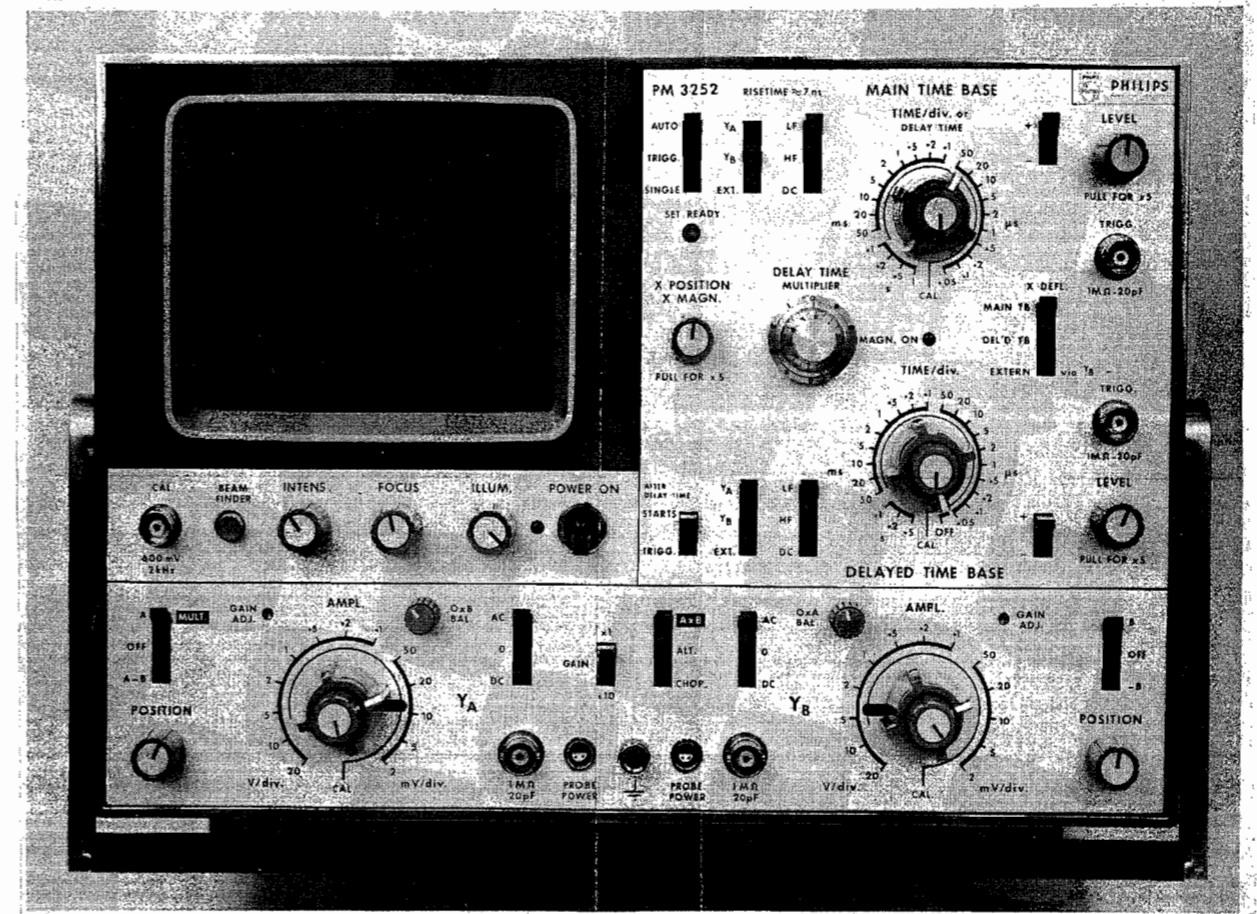
#### 3.1. Schaltungsbeschreibung

##### 3.1.1. Einfügen des Multiplikators

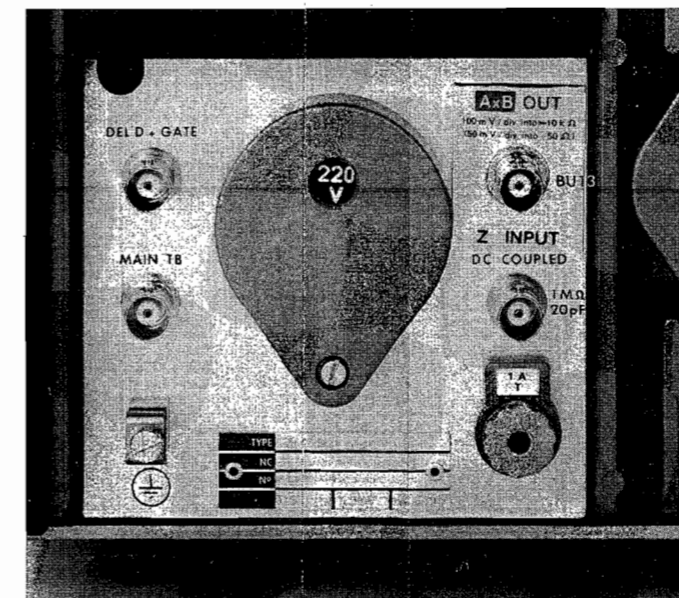
Der Multiplikator wird mit Hilfe von Schutzrohrrelais zwischen die beiden Vorverstärker und den Zwischenverstärker von Kanal A in den Oszillografen eingefügt. Die Relais werden mit Schalter SK23 an der Vorderseite des Geräts betätigt. Wenn Schalter SK23 sich in der oberen Stellung (MULT) befindet, kommt die Betriebsspannung von  $-12\text{ V}$  an die Spulen der Relais RE2201/RE2202, wodurch deren Kontakte geschlossen werden. Die Kontakte der Relais RE2203/RE2204 werden geöffnet, da eine negative Spannung über Widerstand R2292 den Transistor TS2214 sperrt.

Eine negative Spannung über Widerstand R2294 bringt die Dioden GR2208/GR2209 zum Leiten. Eventuelle HF-Spannungen, die über die Streukapazität der Relaiskontakte gelangen, werden über Kondensator C2218 und Diode GR2209 an Erde abgeleitet. Gleichzeitig werden die Dioden GR2211/GR2212 durch die negative Spannung, über Widerstand R2297, an der Anode der Diode GR2211 gesperrt.

In den beiden anderen Positionen (ALT/CHOP) von SK23 ist die Betriebsspannung von  $-12\text{ V}$  unterbrochen, so dass die Kontakte der Relais RE2201/RE2202 geöffnet sind.

Die Basis von Transistor TS2214 wird über Widerstand R2295 positiv, wodurch dieser Transistor leitet und die Kontakte der Relais RE2203/RE2204 geschlossen werden. Die Dioden GR2208/GR2209 werden durch eine positive Spannung über Widerstand R2296 an der Katode der Diode GR2208 gesperrt.

Gleichzeitig leiten die Diode GR2211/GR2212, wodurch eventuelle HF-Spannungen von der Multiplikatorstufe über Kondensator C2219 und Diode GR2212 an Erde abgeleitet werden.

##### 3.1.2. Arbeitsweise

Der gewählte Multiplikatortyp\* nutzt eine bekannte Eigenschaft des bipolaren Transistors aus, nämlich, dass seine Steilheit linear proportional zum Emittterstrom ist.



Abb. 3.1.1. Prinzipschaltung des Multiplikators

\* Das Prinzip der Multiplikatoren wurde in Abschnitt 7.5.5. des Buches *Operationsverstärker von Tobey, Graeme & Huelsman* beschrieben.

Herausgegeben von Mc-Graw-Hill Book Company, New York 1971.

Wenn zwei ausgesuchte bipolare Transistoren aus einer gemeinsamen Emittterstromquelle gespeist werden (siehe Abb. 3.1.1.), ist der differentielle Kollektorstrom proportional dem Produkt der differentiellen Eingangsspannung  $V_A$  und der Steilheit  $g_m$ :

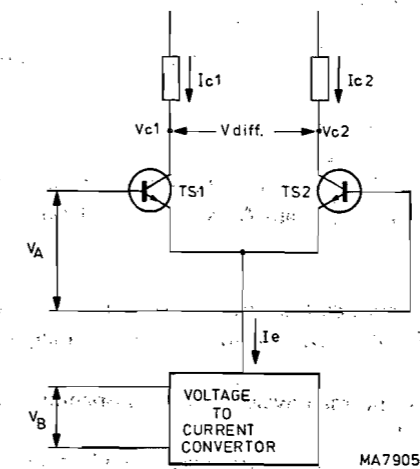
$$I_{c1} - I_{c2} \sim V_A \times g_m \quad (1)$$

Da  $g_m$  eine lineare Funktion von  $I_e$  ist, wird Formel (1):

$$I_{c1} - I_{c2} \sim V_A \times I_e \quad (2)$$

$I_e$  wird von einem Spannungs-Strom-Umsetzer gesteuert.

Der Ausgangsstrom dieses Umsetzers kann als lineare Funktion von  $V_B$  angesehen werden und deshalb ist:

$$I_{c1} - I_{c2} \sim V_A \times V_B \quad (3)$$

$I_{c1}$  und  $I_{c2}$  fließen durch die Kollektorwiderstände und erzeugen dort die Spannungen  $V_{c1}$  und  $V_{c2}$ .

$$V_{c1} - V_{c2} = V_{diff.} \sim V_A \times V_B \quad (4)$$

Daraus folgt, dass die Grundschaltung von Abb. 3.1.1. multiplizieren kann.

Diese Schaltung besitzt jedoch einige schwerwiegende Nachteile:

- Durch die Diodencharakteristik der Eingangsimpedanz hängt die Linearität der Kennlinie stark von  $V_A$  ab.
- Wenn der Multiplikator in allen 4 Quadranten arbeiten soll, muss der Spannungs-Strom-Umsetzer vorgespannt werden, so dass ein beträchtlicher  $I_e$  fließt, wenn  $V_B$  0 ist. Positive und negative Steuerung von  $V_B$  ist nun allerdings möglich, doch wird hierdurch das Übersprechen von  $V_A$  auf die Ausgangsspannung erheblich vergrößert, da  $g_m$  höher als 0 ist, wenn  $V_B = 0$ .
- Die Gleichtaktspannungen an den Kollektoren ändern sich mit  $I_e$  und damit mit  $V_B$ . Obgleich dies die differentielle Ausgangsspannung nicht beeinflusst, erfordert diese Änderung der Gleichtaktspannung einen Ausgangsverstärker mit einer sehr hohen Gleichtaktunterdrückung, um Rückwirkungen von  $V_B$  auszuschalten.
- Dieser Multiplikator ist wegen der "harten" Spannungsansteuerung von Eingang A besonders temperatur-empfindlich.



Abb. 3.1.2. Vereinfachtes Schaltbild des Multiplikators im PM 3252

In der Multiplikatorschaltung von Abb. 3.1.2. kann das Grundprinzip von Abb. 3.1.1. leicht wiedererkannt werden. Die wesentlichen Unterschiede zwischen den beiden Schaltungen sind:

- Das Transistorpaar von Abb. 3.1.1. wurde aufgeteilt in zwei Paare TS1/TS2 und TS3/TS4, von denen jedes mit der Hälfte einer symmetrischen Emittterstromquelle gespeist wird. Durch diese Aufteilung und das kreuzweise Anschliessen der Eingänge und der Ausgänge der beiden Transistorpaare wird das Übersprechen von einem Eingangssignal, wenn das andere Null ist, durch Symmetrierung ausgeschaltet.

- b. Die "harte" Ansteuerung von Eingang A wurde durch eine Ansteuerung über eine Diodentransistorschaltung ersetzt, die als "Stromspiegel" (current mirror) bekannt ist. Die Linearitätsfehler der Schaltung von Abb. 3.1.1. wurden mit den Dioden GR1 und GR2 reduziert, die von der symmetrischen Stromquelle TS5/TS6 gespeist werden. GR1 und GR2 sind als Dioden geschaltete Transistoren. Diese Transistoren befinden sich in demselben monolithischen Chip wie die Transistoren TS1, TS2, TS3 und TS4, damit einwandfreie Anpassung und Temperaturgleichlauf gewährleistet sind. Auf diese Weise wird eine gute Linearität in einem grossen Spannungsbereich erreicht und werden Temperatureinflüsse ausgeschaltet.

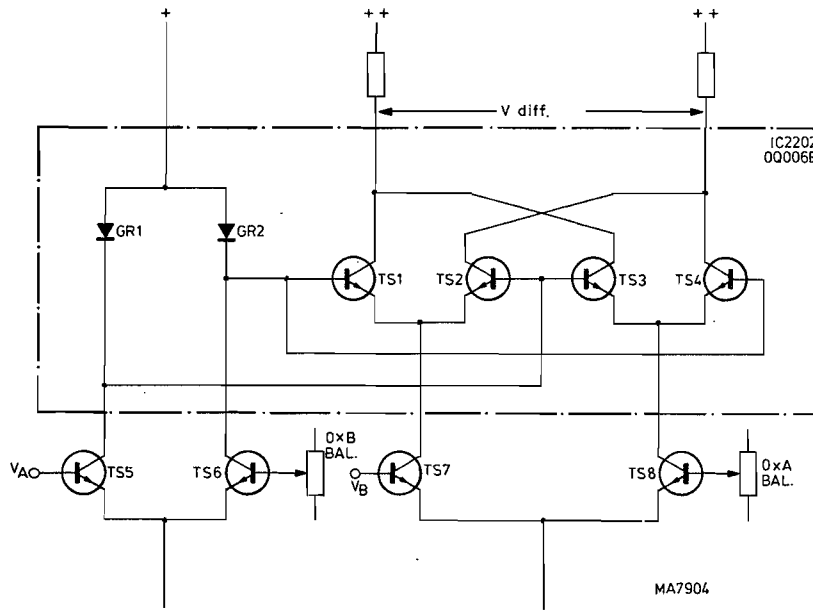
Die Gleichtaktspannung am Ausgang ist eine konstante Gleichspannung, die in einem Differentialverstärker abgetrennt werden kann, in dem aus einem Differenzsignal ein auf den Nullpegel bezogenes Eintaktsignal gemacht wird. Da die Eingangssignale dieses Multiplikators unsymmetrische Spannungen sind, wird mit einem Pol dieses Eingangssignals der Signaleingang gesteuert und erhält der andere eine einstellbare Gleichspannung, mit der die Verschiebung des Eingangs eliminiert werden kann.

### 3.1.3. Signalverarbeitung

Die Eingangssignale für den Multiplikator werden von den Vorverstärkern der beiden Kanäle abgenommen. Das Signal von Kanal A (R191, Einheit 15) gelangt über Relais RE2201 an den Phasenspalter, die integrierte Schaltung IC2203, der für eine symmetrische Steuerung der Stromquelle IC2201/TS2208 sorgt. Die Kollektorspannungen der Transistoren in der Stromquelle IC2201 steuern die Basisspannungen der Transistoren in der integrierten Schaltung IC2202. Die Spannungszuführung für die integrierte Schaltung IC2201 erfolgt über den Emitterfolger TS2208, der mit der Diode GR2204 temperaturstabilisiert ist. Das Signal von Kanal B (R15, Einheit 19) gelangt über den Feldeffekttransistor TS2216a an den Spannungs-Strom-Umsetzer IC2204, der die Emitterströme der Transistoren in IC2202 steuert. TS2202, TS2203, TS2209 und TS2211 bilden einen Differentialverstärker mit hoher Gleichtaktunterdrückung. Er besitzt zwei asymmetrische Ausgänge mit Erdpotential, einen für die Ablenkung der Elektronenstrahlröhre und den anderen für externe Zwecke.

In dieser Stufe wird die Verstärkung so eingestellt, dass der gesamte Massstabfaktor 1 beträgt.

Mit Potentiometer R2223 ist der Massstabfaktor des Produktsignals für die Ablenkung der Elektronenstrahlröhre einzustellen. Über die Pufferstufe TS2206/TS2207 kommt das Produktsignal bei R1601 (Einheit 26) in den Zwischenverstärker. Mit Potentiometer R2229 kann die Verschiebung der Ausgangsspannung beseitigt werden.

Der Massstabfaktor des Produktsignals am Ausgang AxB muss mit R2272 eingestellt werden. Je nach Lage der Drahtbrücken SK2201/SK2202 kommt das Signal direkt oder über den integrierenden Kreis mit IC2206 an die Pufferstufe TS2212/TS2213.

Die Verschiebespannungen können mit Potentiometer R2283 eliminiert werden.

Die Ausgangsimpedanz wird mit Potentiometer R2286 auf  $50 \Omega$  eingestellt.

Mit einem  $50\text{-}\Omega$ -Kabel kommt das Produktsignal an die Buchse BU13 an der Rückseite des Oszillografen.



## 3.2. Prüfen und Einstellen

### 3.2.1. Allgemeine Hinweise

Hier werden nur die Punkte beschrieben, die der PM 3250 nicht besitzt.

Vor den folgenden Prüf- und Einstellarbeiten ist es unbedingt erforderlich, dass der Oszilloskop, mit Ausnahme des Multiplikators, so eingestellt ist, wie es in Abschnitt IX der Anleitung des PM 3250 beschrieben ist.

Vor den Prüf- und Einstellarbeiten das Gerät 30 Minuten bei einer Temperatur von wenigstens 23 °C vorwärmen lassen. (Bei grossen Temperaturabweichungen müssen die Temperaturkoeffizienten mit berücksichtigt werden.)

Für eine genaue Kalibrierung wird eine Anwärmzeit von 1 Stunde empfohlen, wobei die Gehäuseplatten nicht abgenommen sein dürfen.

Alle hier genannten Einstellorgane ohne Positionsnummer befinden sich an der Vorderseite.

Folgende Knöpfe sind einzustellen:

Triggerschalter der Hauptzeitablenkung auf: AUTO,  $Y_A$ , LF und +.

Schalter MAIN TIME-BASE auf 0,1 ms/Teil (stufenlose Einstellung auf CAL).

Schalter X DEFL auf MAIN TB

Triggerschalter der verzögerten Zeitablenkung auf: STARTS,  $Y_A$ , LF und +.

Schalter DELAYED TIME-BASE auf OFF (stufenlose Einstellung auf CAL).

Schalter GAIN auf x1

Feineinstellung AMPL auf CAL

Die übrigen Bedienungsorgane sind den Erfordernissen entsprechend einzustellen.

Empfohlene Messgeräte (siehe Abb. 3.2.1.).

Digital-Multimeter (z.B. Philips PM 2422A).

Konstant-Amplitude-Generator (z.B. Tektronix Generator Typ 191)

NF-Generator, Klirrfaktor < 0,5 % (z.B. Philips PM 5126).

HF-Oszilloskop mit 50- $\Omega$ -Eingang, Bandbreite  $\geq$  150 MHz (z.B. Philips PM 3400)

Gleichspannungsquelle (z.B. Philips PE 1509).

Impulsgenerator mit einer Anstiegszeit < 2 ns (z.B. Philips PM 5775).



Abb. 3.2.1. Empfohlene Messgeräte

### 3.2.2. Gleichspannungssymmetrie

- Schalter A (MULT)/OFF/A–B auf A (MULT) stellen.
- Beide Schalter AC/0/DC auf 0 stellen.
- Schalter AxB/ALT/CHOP auf ALT stellen.
- Schalter B/OFF/–B auf B stellen.
- Beide Schalter AMPL auf 20 mV/Teil stellen.
- Die Spannungen an den Emittern von TS313 (TS113) (Abb. 3.2.2.) mit einem Digital-Multimeter messen. Diese Spannungen müssen  $0\text{ V} \pm 1,0\text{ mV}$  betragen.
- Falls erforderlich, die Gleichspannungssymmetrie korrigieren, wie es in der Anleitung des PM 3250 in Abschnitt XI, Punkt D.a. beschrieben ist.
- Schalter AxB/ALT/CHOP auf AxB stellen.

- Mit einem Digital-Multimeter prüfen, ob die Spannung an Eingang A der Multiplikatorleiterplatte (siehe Abb. 3.2.3.) nicht mehr als  $\pm 0,5$  mV von der am Emitter von TS113 gemessenen Spannung abweicht. Falls erforderlich, R2258 auf der Multiplikatorleiterplatte neu einstellen (siehe Abb. 3.2.3.).
- Mit einem Digital-Multimeter prüfen, ob die Spannung an Eingang B der Multiplikatorleiterplatte (siehe Abb. 3.2.3.) nicht mehr als  $\pm 0,5$  mV von der am Emitter von TS313 gemessenen Spannung abweicht. Falls erforderlich, R452 auf der Zwischenverstärker-Leiterplatte neu einstellen (siehe Abb. XIV-7 in der Anleitung des PM 3250).

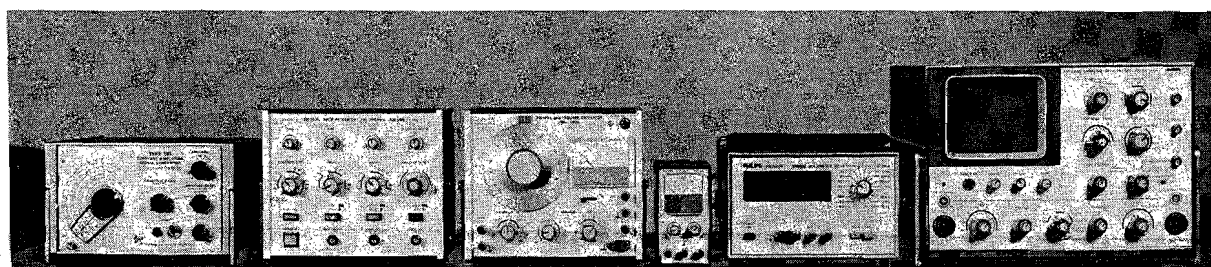

Abb. 3.2.2. Lage des Transistors TS313 (TS113) im Vorverstärker



Abb. 3.2.3. Einstellorgane der Multiplikatorplatte

### 3.2.3. 0xA-Symmetrierung

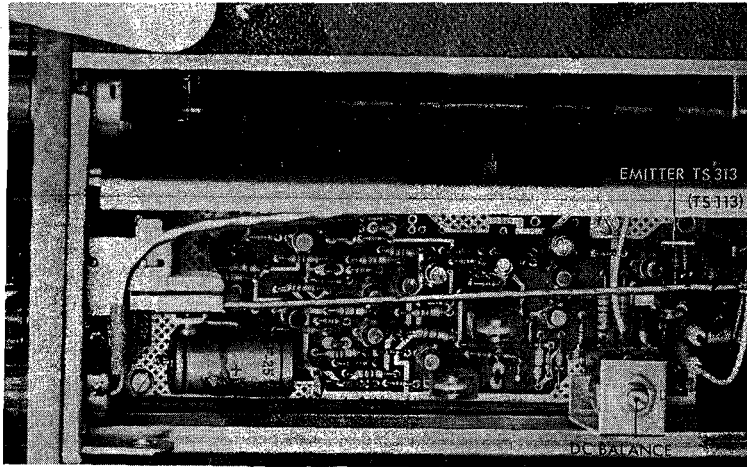
- Schalter A (MULT)/OFF/A–B in Stellung A (MULT) stellen.
- Schalter AC/0/DC von Kanal A auf AC stellen.
- Schalter AC/0/DC von Kanal B auf 0 stellen.
- Schalter AxB/ALT/CHOP auf ALT stellen.
- Schalter B/OFF/–B auf B stellen.
- Beide Schalter AMPL auf 20 mV/Teil stellen.
- Die Spur mit Potentiometer  $Y_A$  POSITION auf dem Schirm zentrieren.
- Eine Sinusspannung mit einer Amplitude von  $160\text{ mV}_{SS}$  und einer Frequenz von 2 kHz an Eingang  $Y_A$  anschliessen.
- Schalter AxB/ALT/CHOP auf AxB stellen.
- Potentiometer 0xA BAL so einstellen, dass das Signal als gerade horizontale Linie abgebildet wird. Die Abweichungen müssen kleiner als 0,2 Teile sein.

### 3.2.4. 0xB-Symmetrierung

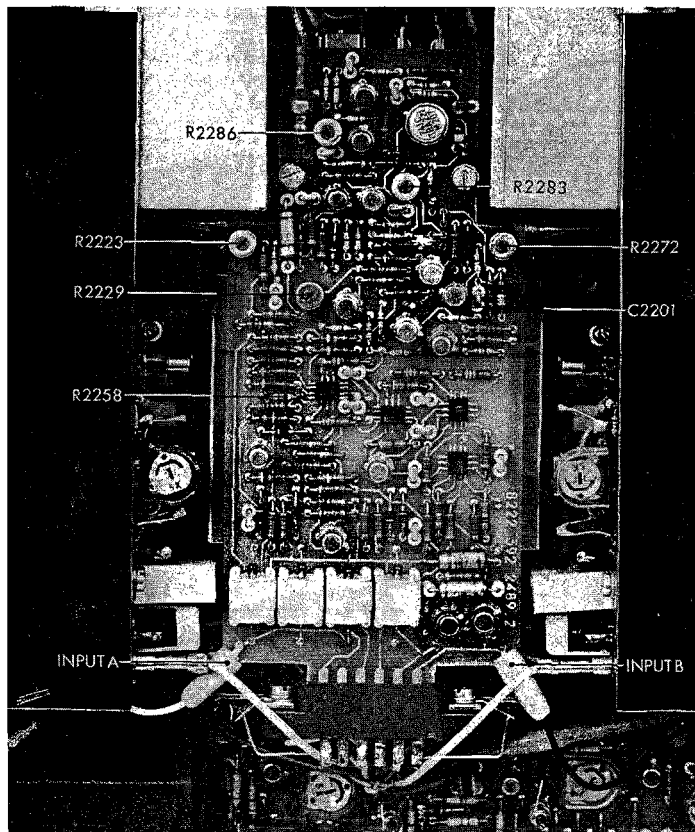
- Schalter A (MULT)/OFF/A–B auf A (MULT) stellen.
- Schalter AC/0/DC von Kanal A auf 0 und den von Kanal B auf AC stellen.
- Schalter AxB/ALT/CHOP auf ALT stellen.
- Schalter B/OFF/–B auf B stellen.
- Beide Schalter AMPL auf 20 mV/Teil stellen.
- Die Spur mit Potentiometer  $Y_B$  POSITION auf dem Schirm zentrieren.
- Eine Sinusspannung mit einer Amplitude von  $160\text{ mV}_{SS}$  und einer Frequenz von 2 kHz an Eingang  $Y_B$  anschliessen.
- Schalter AxB/ALT/CHOP auf AxB stellen.
- Potentiometer 0xB BAL so einstellen, dass das Signal als gerade horizontale Linie abgebildet wird. Die Abweichungen müssen kleiner als 0,2 Teile sein.

*Anmerkung: Die Stellung der beiden Potentiometer 0xA BAL und 0xB BAL darf bei den folgenden Einstellungen nicht geändert werden.*

### 3.2.5. Verschiebung (off-set)

- Schalter A (MULT)/OFF/A–B auf A (MULT) stellen.
- Beide Schalter AC/0/DC auf AC stellen.
- Schalter B/OFF/–B auf B stellen.
- Schalter AxB/ALT/CHOP von ALT auf AxB umschalten.
- Prüfen, ob bei diesem Umschalten die Nulllinie auf dem Schirm um nicht mehr als 0,2 Teile springt.
- Falls erforderlich, Potentiometer R2229 neu einstellen (siehe Abb. 3.2.3.).

### 3.2.6. Verschiebung des externen Ausgangs

- Schalter A (MULT)/OFF/A–B auf A (MULT) stellen.
- Beide Schalter AC/0/DC auf AC stellen.



Abb. 3.2.4. Stellung "AUGENBLICKSWERT" der Drahtbrücken SK2201/SK2202



Abb. 3.2.5. Stellung "MITTELWERT" der Drahtbrücken SK2201/SK2202

- Schalter AxB/ALT/CHOP auf AxB stellen.
- Schalter B/OFF/–B auf B stellen.
- Die Drahtbrücken SK2201 und SK2202 auf der Multiplikator-Leiterplatte auf "AUGENBLICKSWERT" stellen (siehe Abb. 3.2.4.).
- Prüfen, ob der Ausgangspegel an Buchse BU13 an der Rückseite des Gerätes 0 ist, mit einer maximalen Abweichung von  $\pm 10$  mV.
- Falls erforderlich, Potentiometer R2283 neu einstellen (siehe Abb. 3.2.3.).

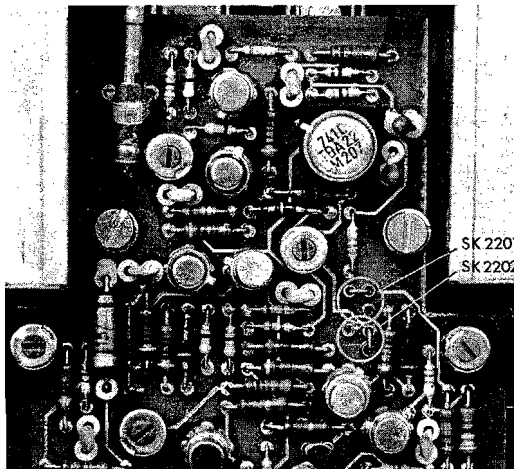
### 3.2.7. Masstabfaktor

- Schalter A (MULT)/OFF/A–B auf A (MULT) stellen.
- Beide Schalter AC/0/DC auf AC stellen.
- Schalter AxB/ALT/CHOP auf ALT stellen.
- Schalter B/OFF/–B auf B stellen.
- Beide Schalter AMPL auf 20 mV/Teil stellen.
- Die Drahtbrücken SK2201 und SK2202 auf der Multiplikatorleiterplatte auf "MITTELWERT" stellen (siehe Abb. 3.2.5.).
- Eine Sinusspannung von 2 kHz mit einer Amplitude von 80 mV<sub>SS</sub> an beide Eingänge Y<sub>A</sub> und Y<sub>B</sub> anschliessen.
- Schalter AxB/ALT/CHOP auf AxB stellen.
- Prüfen, ob die Höhe des Oszillogramms genau vier Teile beträgt.  
Falls erforderlich, R2223 neu einstellen (siehe Abb. 3.2.3.).
- Ein Digital-Multimeter an die Ausgangsbuchse AxB (BU13) an der Rückseite des Gerätes anschliessen.
- Beide Schalter AC/0/DC auf 0 stellen.
- Die Ausgangsverschiebespannung V<sub>off</sub> messen.
- Beide Schalter AC/0/DC auf AC zu stellen.
- Prüfen, ob die Ausgangsspannung V<sub>off</sub> +200 mV  $\pm 2$  mV beträgt.
- Falls erforderlich, Potentiometer R2272 neu einstellen (siehe Abb. 3.2.3.).
- Den Ausgang AxB mit 50  $\Omega$  abschliessen.
- Mit dem Digital-Multimeter prüfen, ob die Ausgangsspannung gegenüber dem bei nicht abgeschlossenen Ausgang gemessenen Wert halbiert ist.  
Falls erforderlich, Potentiometer R2286 neu einstellen (siehe Abb. 3.2.3.).

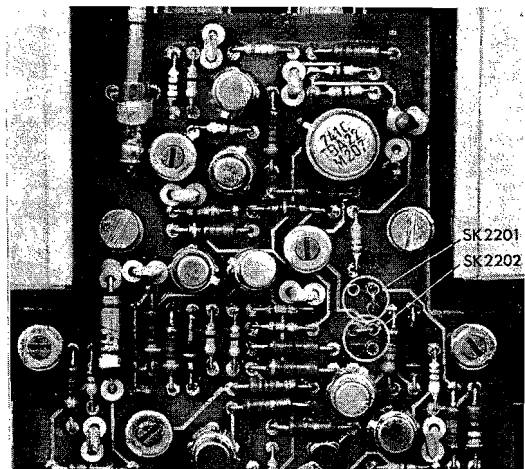
### 3.2.8. Linearitätsfehler

- Schalter A (MULT)/OFF/A–B auf A (MULT) stellen.
- Schalter AC/0/DC von Kanal A auf DC stellen.
- Schalter AC/0/DC von Kanal B auf AC stellen.
- Schalter AxB/ALT/CHOP auf AxB stellen.
- Schalter B/OFF/–B auf B stellen.
- Beide Schalter AMPL auf 20 mV/Teil stellen.
- Schalter X DEFL auf EXTERN via Y<sub>B</sub> stellen.
- Die Potentiometer Y<sub>A</sub> und Y<sub>B</sub> POSITION so einstellen, dass der abgebildete Punkt sich in Schirmmitte befindet. Eine Sinusspannung mit einer Amplitude von 160 mV<sub>SS</sub> und einer Frequenz von 1 kHz an Eingang Y<sub>B</sub> anschliessen.
- Nacheinander Gleichspannungen mit Amplituden von –4 Teilen, –2 Teilen, –1 Teil, –0,5 Teil, 0 Teil, +0,5 Teil, +1 Teil, +2 Teile und +4 Teile an Eingang Y<sub>A</sub> anschliessen. Den Abschwächerschalter Y<sub>A</sub> jeweils richtig einstellen.
- Jede Gleichspannung ergibt eine Linie, die durch den Schirmmittelpunkt läuft und sich in einem bestimmten Winkel zur horizontalen Linie befindet.
- Prüfen, ob die Nichtlinearität, das ist die maximale Abweichung der abgebildeten Linie gegenüber einer Geraden, 0,16 Teile nicht überschreitet (siehe Punkt 1.4.8.).

### 3.2.9. Anstiegszeit des Multiplikators

- Schalter A (MULT)/OFF/A–B auf A (MULT) stellen.
- Schalter AC/0/DC von Kanal A auf AC und den von Kanal B auf DC stellen.
- Schalter X DEFL auf MAIN TB stellen.
- Schalter AxB/ALT/CHOP auf ALT stellen.
- Schalter B/OFF/–B auf B stellen.
- Beide Schalter AMPL auf 20 mV/Teil stellen.
- Schalter MAIN TIME-BASE auf 0,05  $\mu$ s/Teil stellen.
- Einen Impuls mit einer Anstiegszeit  $< 2$  ns und einer Amplitude von 40 mV an Eingang Y<sub>A</sub> anschliessen.

- Eine Gleichspannung mit einer Amplitude von 1 Teil an Eingang  $Y_B$  anschliessen.
- Schalter X MAGN in Stellung x5 herausziehen.
- Schalter AxB/ALT/CHOP auf AxB stellen.
- Prüfen, ob die Oberseite des abgebildeten Impulses gerade ist.  
Falls erforderlich, Kondensator C2201 einstellen (siehe Abb. 3.2.3.).
- Prüfen, ob die Anstiegszeit  $\leq 9$  ns ist.
- Die Impulswiedergabe und die Anstiegszeit auch prüfen, wenn das Gleichspannungssignal an Eingang  $Y_A$  und der Impuls an Eingang  $Y_B$  angeschlossen wird.
- Falls erforderlich, Kondensator C2227 einstellen (Lage siehe Abb. 3.4.1., MA7995).

### 3.2.10. Bandbreite des Multiplikators

- Schalter A (MULT)/OFF/A–B auf A (MULT) stellen.
- Schalter AC/0/DC von Kanal A auf AC und den von Kanal B auf DC stellen.
- Schalter AxB/ALT/CHOP auf ALT stellen.
- Schalter B/OFF/–B auf B stellen.
- Schalter AMPL von Kanal A auf 20 mV/Teil und den von Kanal B den Erfordernissen entsprechend einstellen.
- Schalter MAIN TIME-BASE auf 0,1 ms/Teil stellen.
- Einen Konstant-Amplitude-Generator an Eingang  $Y_A$  anschliessen.
- An diesen Eingang eine Sinusspannung mit einer Amplitude von 80 mV<sub>SS</sub> und einer Frequenz von 50 kHz anschliessen.
- An Eingang  $Y_B$  eine Gleichspannung mit einer Amplitude von 2 Teilen anschliessen.
- Schalter AxB/ALT/CHOP auf AxB stellen.
- Prüfen, ob das Schirmbild genau 8 Teile einnimmt.  
Falls erforderlich, die Amplitudeneinstellung des Konstant-Amplitude-Generators korrigieren.
- Die Generatorfrequenz erhöhen, bis das Signal von 8 Schirmteilen auf 5,6 Teile abgenommen hat.
- Prüfen, ob diese Frequenz  $\geq 40$  MHz ist.
- Die Bandbreite auch prüfen, wenn das Gleichspannungssignal an Eingang  $Y_A$  und das Wechsellspannungssignal an Eingang  $Y_B$  angeschlossen wird.

### 3.2.11. Bandbreite des Multiplikators am Ausgang AxB

- Schalter A (MULT)/OFF/A–B auf A (MULT) stellen.
- Schalter AC/0/DC von Kanal A auf AC und den von Kanal B auf DC stellen.
- Schalter AxB/ALT/CHOP auf ALT stellen.
- Schalter B/OFF/–B auf B stellen.
- Schalter AMPL von Kanal A auf 20 mV/Teil stellen.
- Schalter AMPL von Kanal B so einstellen, wie es erforderlich ist.
- Die Drahtbrücken SK2201 und SK2202 auf "AUGENBLICKSWERT" bringen (siehe Abb. 3.2.4.).
- Einen Konstant-Amplitude-Generator an Eingang  $Y_A$  anschliessen.
- Diesem Eingang eine Sinusspannung mit einer Amplitude von 80 mV<sub>SS</sub> und einer Frequenz von 50 kHz zuführen.
- Eine Gleichspannung mit einer Amplitude von 2 Teilen an Eingang  $Y_B$  anschliessen.
- Den Oszillografen mit 50- $\Omega$ -Eingang an die Ausgangsbuchse AxB (BU13) anschliessen. Schalter mV/cm dieses Oszillografen auf 50 mV stellen und während der Messung für eine Triggerung des Signals sorgen. Prüfen, ob das dargestellte Signal genau 8 Teile beträgt.  
Falls erforderlich, die Amplitude des Konstant-Amplitude-Generators korrigieren.
- Die Generatorfrequenz erhöhen, bis die Amplitude des Signals nur noch 5,6 Teile beträgt. Prüfen, ob diese Frequenz  $\geq 40$  MHz ist.

*Anmerkung: Die Bandbreite kann auch mit einem HF-Voltmeter an der Ausgangsbuchse AxB gemessen werden, die dann mit 50  $\Omega$  abzuschliessen ist.*

### 3.2.12. Übersprechen

- Den Prüf- und Einstellvorgang mit einem Signal von 40 MHz wiederholen, wie es in Abschnitt 3.2.3. und 3.2.4. beschrieben wurde.

### 3.3. Einzelteilliste

#### 3.3.1. Mechanische Einzelteile und komplette Einheit

Pos.	Bestellnummer	Beschreibung
—	5322 455 84011	Textplatte PM 3252
R21, R22	5322 414 34091	Knopf $\varnothing$ 10 mm, Achse $\varnothing$ 4 mm
	5322 414 74015	Kappe für Knopf $\varnothing$ 10 mm
SK23	5322 277 34005	Schiebeschalter
—	5322 267 40115	6 poliger Konnektor für Multiplikator, Einheit 45
Einheit 45	5322 216 54087	Multiplikatorschaltung



Abb. 3.3.1. Frontansicht, Ausschnitt

#### 3.3.2. Halbleiter

Typ	Bestellnummer	Beschreibung
BAX13	5322 130 40182	Diode
BZX79/C15	5322 130 30781	Z-Diode
BY127	5322 130 30259	Diode
OQ002	5322 209 84355	Integrierte Schaltung
OQ006B	5322 209 84356	Integrierte Schaltung
TBA221	5322 209 84112	Integrierte Schaltung
BC109	5322 130 40144	Transistor
BFS21A	5322 130 40709	Feldeffekttransistor
BCY71	5322 130 40373	Transistor
BFY90	5322 130 40493	Transistor
BSX29	5322 130 40205	Transistor

#### 3.3.3. Relais

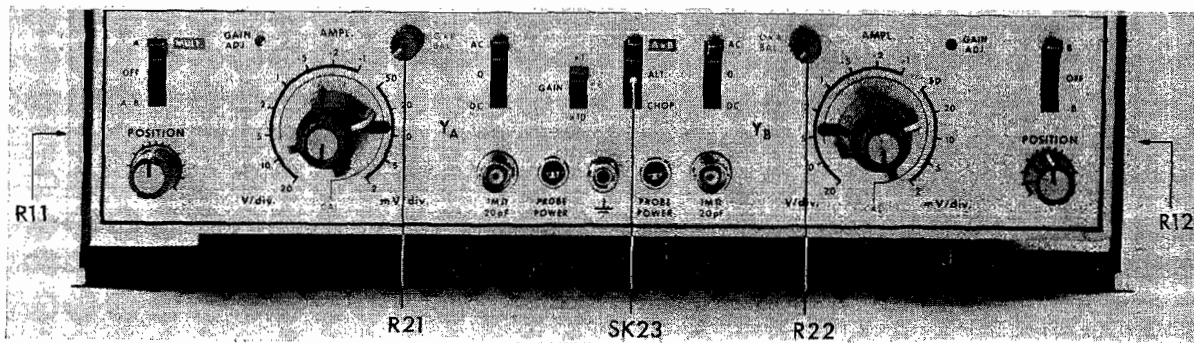
Pos.	Bestellnummer	Beschreibung
RE2201...RE2204	5322 281 64149	Relaisspule (6 V)
	5322 280 24036	Relaiskontakt

## 3.3.4. Kondensatoren

Pos.	Bestellnummer	F	%	V	Beschreibung
C2202...C2204	5322 122 30027	1 n	10	100	Keramischer Scheibenkondensator
C2205	4822 122 30016	33 p	2	100	Keramischer Scheibenkondensator
C2206	4822 124 20358	15 $\mu$		16	Elektrolyt
C2207...C2211	5322 122 30027	1 n	10	100	Keramischer Scheibenkondensator
C2212, C2213	5322 124 14059	22 $\mu$		1.6	Tantalelektrolyt
C2214	5322 122 30043	10 n	-20+100	40	Keramischer Scheibenkondensator
C2216...C2220	5322 122 30027	1 n	10	100	Keramischer Scheibenkondensator
C2221, C2222	4822 124 20355	10 $\mu$		25	Elektrolyt
C2223, C2224	4822 124 20358	15 $\mu$		16	Elektrolyt
C2225	5322 122 30027	1 n	10	100	Keramischer Scheibenkondensator
C2226	4822 122 31165	330 p	10	100	Keramischer Scheibenkondensator

## 3.3.5. Widerstände

CR16 : Kohle-Schichtwiderstand  
 Tmax. hot spot = 155 °C  
 Typische Belastbarkeit bei Umgebungstemperatur (70 °C) = 0,2 W

MR25 : Metall-Schichtwiderstand  
 Tmax. hot spot = 175 °C  
 Typische Belastbarkeit bei Umgebungstemperatur (70 °C) = 0,4 W

Pos.	Bestellnummer	$\Omega$	%	Beschreibung
R11, R12	5322 101 20075	47 k		Kohle-Schichtpotentiometer (CP16)
R21, R22	5322 101 24034	50 k		Kohle-Schichtpotentiometer (Dralowid)
R2201	5322 116 54292	1,69 k	1	MR25
R2202	5322 116 50915	9,53 k	1	MR25
R2204, R2206	5322 116 54248	866	1	MR25
R2207, R2208	5322 116 54183	383	1	MR25
R2211, R2212	5322 111 44012	27	5	CR16
R2213	5322 111 30401	47	5	CR16
R2215	5322 116 50614	3,57 k	1	MR25
R2216, R2217	5322 116 51069	49,9	1	MR25
R2218	5322 116 50524	3,01 k	1	MR25
R2219	5322 116 54136	681	1	MR25
R2221	4822 111 30271	820	5	CR16
R2222	5322 116 54494	187	1	MR25
R2223	5322 100 10144	2 k		Kohle-Schichtpotentiometer (Helitrim)
R2224	5322 116 50664	2,05 k	1	MR25
R2226	5322 116 54283	4,02 k	1	MR25
R2227	4822 111 30272	680	5	CR16
R2228, R2231	5322 111 30356	43	5	CR16
R2229	5322 100 10133	200		Kohle-Schichtpotentiometer (Helitrim)
R2232	5322 116 54283	4,02 k	1	MR25
R2233	4822 111 30272	680	5	CR16
R2234, R2236	5322 116 50832	51,1	1	MR25
R2237	5322 116 50474	42,2 k	1	MR25
R2238, R2239	5322 116 50747	1 k	1	MR25
R2241	5322 116 50608	6,19 k	1	MR25
R2242	5322 116 50749	1,4 k	1	MR25
R2243, R2244	5322 116 54364	59	1	MR25
R2246	5322 116 50747	1 k	1	MR25
R2247, R2249	5322 116 50979	8,25 k	1	MR25

<i>Pos.</i>	<i>Bestellnummer</i>	$\Omega$	%	<i>Beschreibung</i>
R2248	5322 116 50746	100	1	MR25
R2251	5322 116 50669	205	1	MR25
R2252	5322 116 54155	100 k	1	MR25
R2253	5322 116 50747	1 k	1	MR25
R2254, R2257	5322 116 50729	4,22 k	1	MR25
R2255	4822 111 30324	100	5	CR16
R2256	5322 116 50521	56,2	1	MR25
R2259, R2260	5322 116 54538	787	1	MR25
R2261, R2262	5322 116 50571	715	1	MR25
R2263	5322 116 50746	100	1	MR25
R2264	5322 116 54155	100 k	1	MR25
R2265	5322 116 50614	3,57 k	1	MR25
R2266, R2268	5322 111 44012	27	5	CR16
R2267	5322 111 30401	47	5	CR16
R2269	4822 111 30271	820	5	CR16
R2270	5322 116 54283	4,02 k	1	MR25
R2271	5322 116 54358	348	1	MR25
R2272	5322 100 10144	2 k		Kohle-Schichtpotentiometer (Helitrim)
R2273	5322 111 30296	100 k	5	CR16
R2274	4822 111 30333	1 M	5	CR16
R2275	5322 116 54283	4,02 k	1	MR25
R2276	5322 116 50664	2,05 k	1	MR25
R2277, R2279	5322 116 54327	10 k	1	MR25
R2278	5322 111 30378	200	5	CR16
R2280	5322 116 50452	10	1	MR25
R2281	5322 116 54283	4,02 k	1	MR25
R2282	4822 111 30272	680	5	CR16
R2283	5322 100 10133	200		Kohle-Schichtpotentiometer (Helitrim)
R2284, R2288	5322 111 30356	43	5	CR16
R2286	5322 100 10138	100		Kohle-Schichtpotentiometer (Helitrim)
R2287	5322 111 30365	51	5	CR16
R2289	5322 116 54283	4,02 k	1	MR25
R2291	4822 111 30272	680	5	CR16
R2292	5322 116 54327	10 k	1	MR25
R2293	5322 116 50572	12,1 k	1	MR25
R2294, R2297	5322 116 50762	5,11 k	1	MR25
R2296, R2298	5322 116 54327	10 k	1	MR25



**ANMERKUNGEN:**

Die integrierten Schaltungen müssen so angeordnet werden, dass der Kreis auf dem Gehäuse sich bei dem Strich auf der Leiterplatte befindet.

Diodenplatine, Einheit 8 (siehe Bedienungsanleitung des PM 3250, Abb. XIV-15c):

Im PM 3252 wurden zusätzlich 4 Dioden GR2213/14/16/17 (BY127) parallel zu den Dioden GR1201/2/3/4 gelegt, um einen höheren Strom entnehmen zu können.



Abb. 3.4.1. Leiterplatte des Multiplikators, Einheit 45



Abb. 3.4.2. Schaltbild des Multiplikators

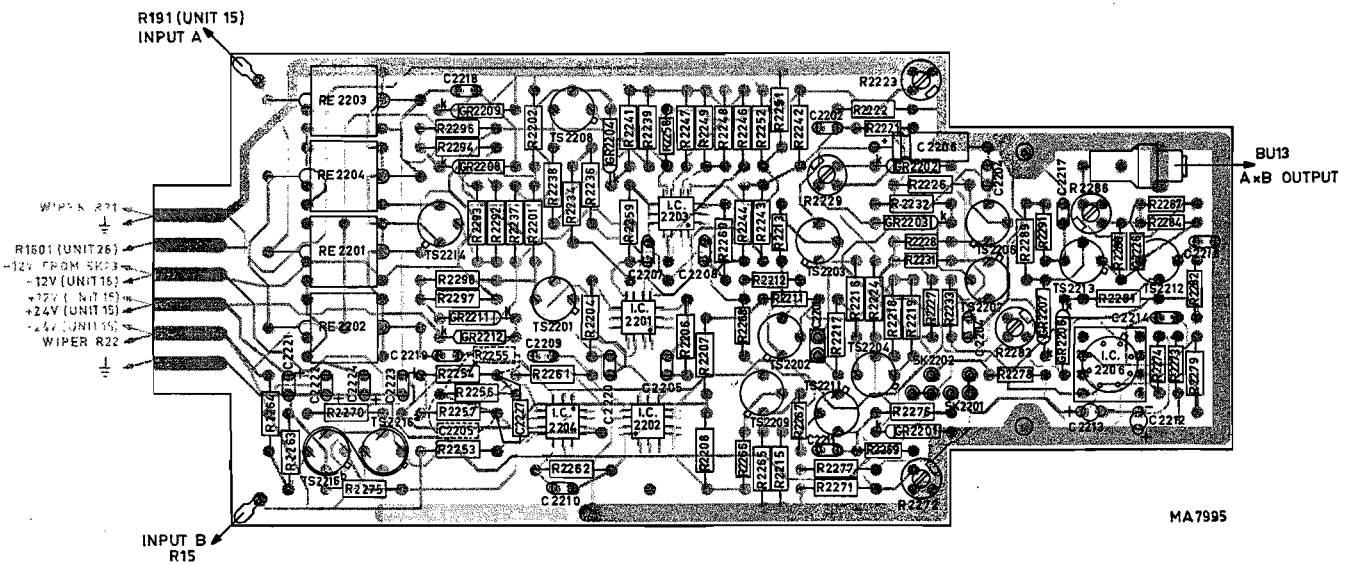
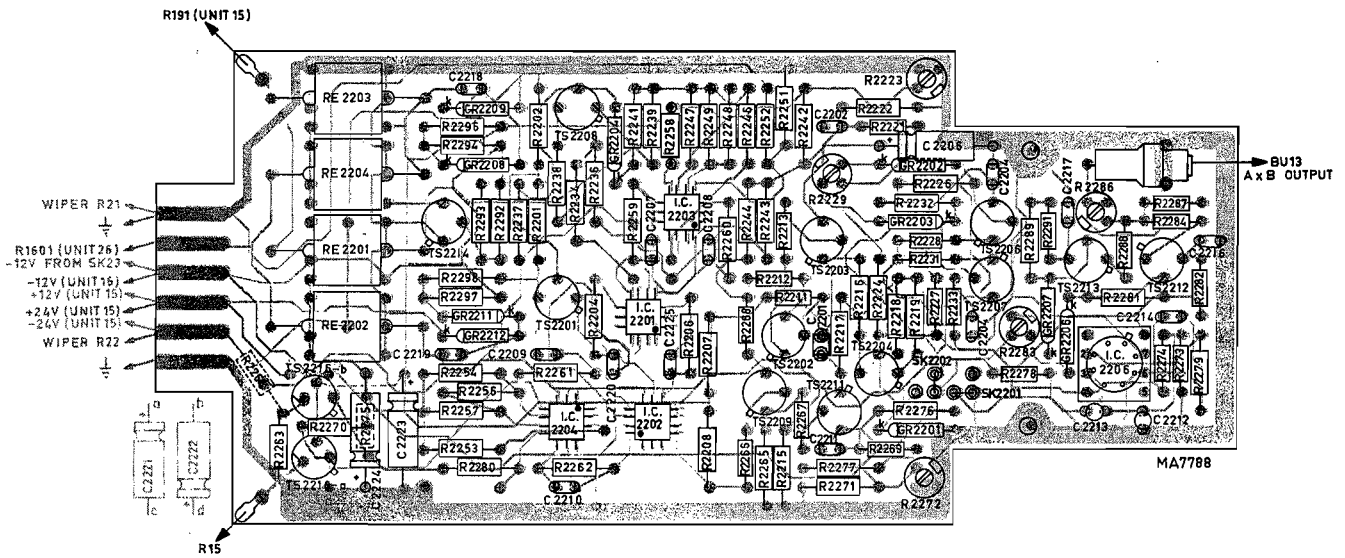

# PHILIPS

## OPERATING MANUAL

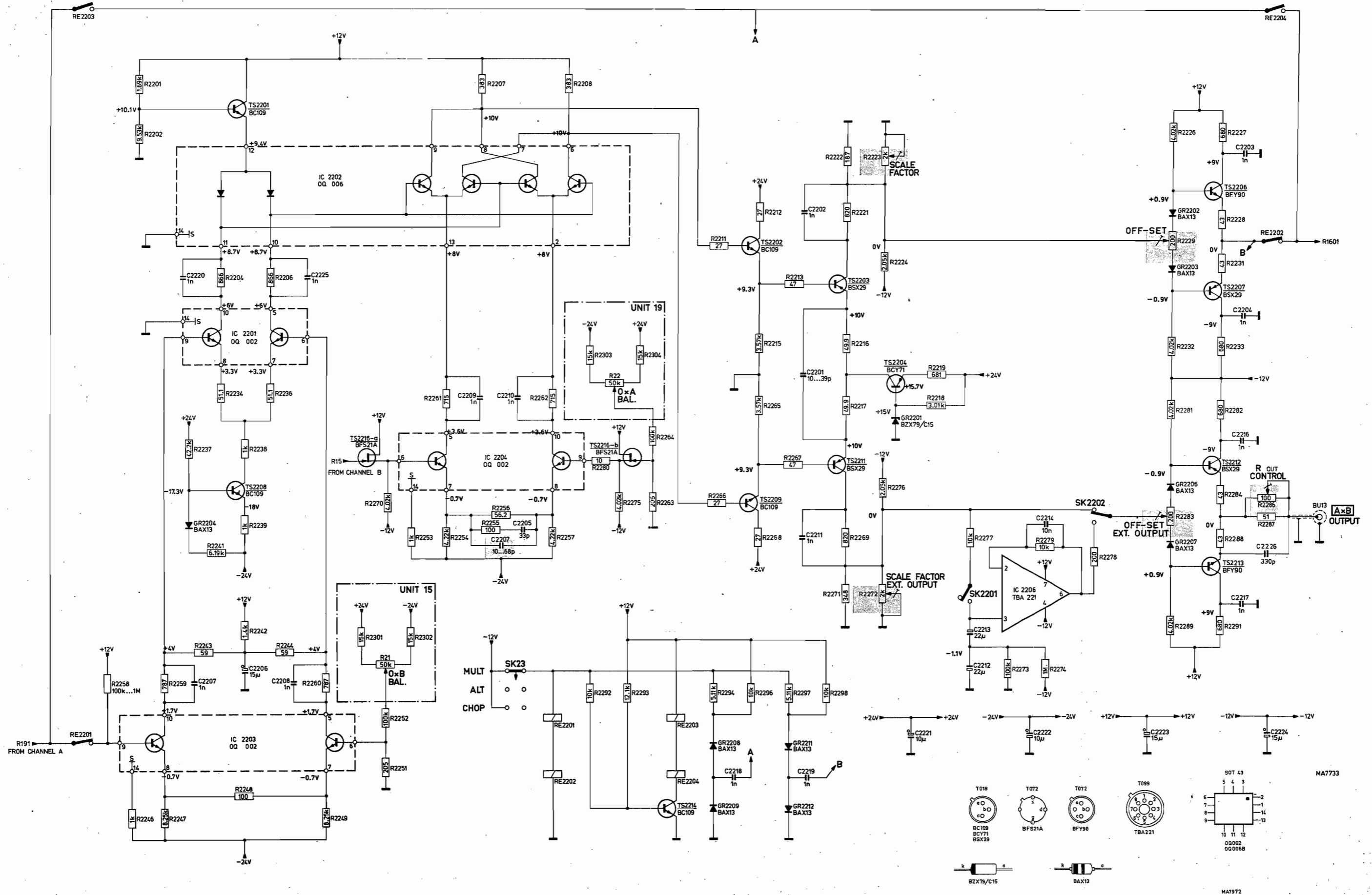
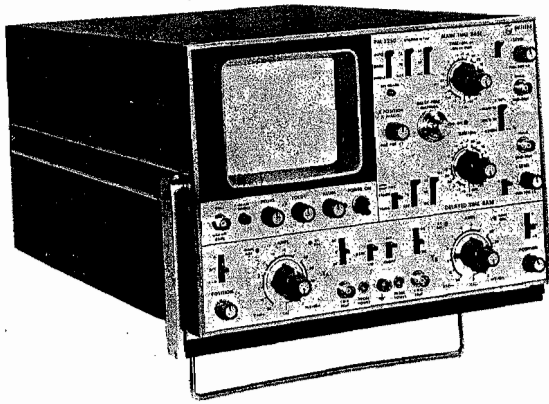
### DOUBLE-TRACE OSCILLOSCOPE **PM3250**

**IMPORTANT**

*In correspondence concerning this apparatus, please quote the type number and serial number as given on the type plate at the rear of the apparatus.*

## Sales and service all over the world

- Argentina:** Philips Argentina S.A., Casilla Correo 3479, Buenos Aires; tel. T.E. 70, 7741 al 7749
- Australia:** Philips Electrical Pty Ltd., Philips House, 69-79 Clarence Street, Box 2703 G.P.O., Sydney; tel. 2.0223
- België/Belgique:** M.B.L.E., Philips Bedrijfsapparatuur, 80 Rue des Deux Gares, Bruxelles; tel. 230000
- Bolivia:** Philips Sudamericana, Casilla 1609, La Paz; tel. 5270-5664
- Brasil:** Messrs. Inbelsa, Rua Amador Bueno 474, Caixa Postal 3159, Sao Paulo; tel. 93-9191
- Burma:** U. Thoung Tin, 36, Barr Street, Rangoon
- Burundi:** Philips S.A.R.L., Avenue de Grèce, B.P. 900, Bujumbura
- Canada:** Philips Electronic Industries Ltd., Electronic Equipment Division, Philips House, 116 Vanderhoof Avenue, Toronto 17, (Ontario); tel. 425-5161
- Chile:** Philips Chilena S.A., Casilla 2687, Santiago de Chile; tel. 35081
- Colombia:** Philips Colombiana S.A., Communications Department, Apartado Nacional 1505, Bogota; tel. 473-640
- Congo:** Philips Congo S.C.R.L., 137, Boulevard du 30 Juin, B.P. 1798, Kinshasa
- Costa Rica:** Philips de Costa Rica Ltd., Apartado Postal 4325, San José; tel. 5670
- Danmark:** Philips A.S., Prags Boulevard 80, København; tel. Asta 2222
- Deutschland (Bundesrepublik):** Philips Elektronik Industrie GmbH, Röntgenstrasse 22, Postfach 630111, 2 Hamburg 63; tel. 501031
- Ecuador:** Philips Ecuador S.A., Casilla 343, Quito; tel. 30064
- Eire:** Philips Electrical (Ireland) Ltd., Newstead, Clonskeagh, Dublin 14; tel. 976611
- El Salvador:** Philips de El Salvador, Apartado Postal 865, San Salvador; tel. 7441
- España:** Philips Ibérica S.A.E., Avenida de America, Apartado 2065, Madrid 17; tel. 246 22 00
- Ethiopia:** Philips Ethiopia (Priv. Ltd. Co.), P.O.B. 659, Cunningham Street, Addis Abeba; tel. 13440
- France:** Philips Industrie S.A., 105 Rue de Paris, 93 Bobigny (Seine); tel. 845 28-55, 845 27-09

- Ghana:** Philips (Ghana) Ltd., P.O.B. M 14, Accra
- Great Britain:** Pye Unicam Ltd., York Street, Cambridge; tel. (0223)58866
- Guatemala:** Philips de Guatemala S.A., Apartado Postal 238, Guatemala City; tel. 20607-08-09
- Hellas:** Philips S.A. Hellénique, B.P. 153, Athens; tel. 230476
- Hong Kong:** Philips Hong Kong Ltd., P.O.B. 2108, Rooms 1006/1008 Prince's Building, Hong Kong; tel. H-249246
- India:** Philips India Ltd., Shivsagar Estate, Block "A", Dr. Annie Besant Road, P.O.B. 6598, Worli, Bombay 18; tel. 370071
- Indonesia:** P.T. Philips Development Corporation, Djalan Pegangsaan Timur 33, P.O.B. 2287, Djakarta
- Iran:** Philips Iran Ltd., P.O.B. 1297, Teheran; tel. 48344-68344
- Island:** Heimilistaeki SF, Saetún 8, Reykjavik; tel. 24000
- Islas Canarias:** Philips Ibérica S.A.E., Triana 132, Las Palmas; Casilla 39-41, Santa Cruz de Tenerife
- Italia:** Philips S.p.A., Casella Postale 3992, Milano; tel. 69.94
- Kenya:** Philips (Kenya) Ltd., P.O.B. 9970, Nairobi; tel. 26204/5
- Malaysia:** Philips Malaya Sdn Berhad, P.O.B. 2163, Kuala Lumpur
- Mexico:** Philips Comercial S.A. de C.V., Uruapan 7, Apdo 24-328, Mexico 7 D.F.; tel. 25-15-40
- Nederland:** Philips Nederland N.V., Boschdijk VB, Eindhoven; tel. 43-33-33
- Ned. Antillen:** N.V. Philips Antillana, Postbus 523, Willemstad; tel. Curaçao 36222-35464
- New Zealand:** Philips Electronical Industries (N.Z.) Ltd., Professional and Industrial Division, 70-72 Kingsford Smith Street, P.O.B. 2097, Lyall Bay, Wellington; tel. 73-156
- Nigeria:** Philips (Nigeria) Ltd., Philips House, 6, Ijora Causeway, P.O.B. 1921, Lagos; tel. 56051/2
- Nippon:** Philips Products Sales Corporation of Japan, P.O.B. 13, Trade Center, Tokyo 105; tel. (03)435-5211
- Norge:** Norsk A.S. Philips, Postboks 5040, Oslo; tel. 463890
- Osterreich:** Oesterreichische Philips Industrie GmbH, Abteilung Industrie Elektronik, Triesterstrasse 64, A-1101 Wien; tel. (0222)645511/31
- Pakistan:** Philips Electrical Co. of Pakistan Ltd., Bunder Road, P.O.B. 7101, Karachi; tel. 70071
- Paraguay:** Philips del Paraguay S.A., Casilla de Correo 605, Asuncion; tel. 8045-5536-6666
- Perú:** Philips Peruana S.A., Apartado Postal 1841, Lima; tel. 34620-40265
- Philippines:** Electronic Development & Application Center, 2246 Pasong Tamo Street, P.O.B. 911, Makati Commercial Center, Makati Rizal D-708
- Portugal:** Philips Portuguesa S.A.R.L., Rua Joaquim Antonio d'Aquiar 66, Lisboa; tel. 683121/9
- Rwanda:** Philips Rwanda S.A.R.L., B.P. 449, Kigali
- Schweiz-Suisse-Svizzera:** Philips A.G., Binzstrasse 38, Postfach, 8027 Zürich; tel. 051-44 22 11
- Singapore:** Philips Singapore Ltd., 8th Floor, International Bld, 360 Orchard Road, P.O.B. 1358, Singapore; tel. 362211
- South Africa:** South African Philips (Pty) Ltd., P.O.B. 7703, 2, Herb Street, New Doornfontein, Johannesburg; tel. 24-0531
- Suomi:** Oy Philips Ab, Postboks 10255, Helsinki 10; tel. 10915
- Sverige:** Svenska A.B. Philips, Fack, Lidingövägen 50, Stockholm 27; tel. 08/635000
- Taiwan:** Yung Kang Trading Co. Ltd., 6 Nan King East Road, 1 Section, P.O.B. 1467, Taipei; tel. 543540-553528
- Tanzania:** Philips (Tanzania) Ltd., p/a P.O.B. 9970, Nairobi, Kenya
- Thailand:** Philips Thailand Ltd., 283, Silom Road, Bangkok; tel. 36985-8
- Türkiye:** Türk Philips Ticaret A.S., Post Kutusu 504, Istanbul; tel. 447486
- Uruguay:** Philips de Uruguay, Avda Uruguay 1287, Montevideo; tel. 956 41-2-3-4
- U.S.A.:** Philips Electronic Instruments, 750 South Fulton Ave., Mount Vernon, N.Y. 10550; tel. (914) 664-4500
- Venezuela:** C.A. Philips Venezolana, Apartado Postal 1167, Caracas; tel. 72 01 51
- Zambia:** Philips Electrical Ltd., Professional Equipment Division, P.O.B. 553, Kitwe; tel. 2526/7/8

# Contents

<b>GENERAL INFORMATION</b>	<b>7</b>
I. Introduction	7
II. Technical data	8
III. Accessories	13
IV. Description of the block diagram	14
A. General	14
B. Dual channel vertical system	14
C. Time-bases	15
D. Horizontal amplifier	15
E. Other units	15
<b>DIRECTIONS FOR USE</b>	<b>21</b>
V. Installation	21
A. Mains adjustment and fuses	21
B. Earthing	21
C. Switching on	21
VI. Knobs, sockets and their functions	22
VII. Operation	28
A. Preliminary settings	28
1. Adjusting the d.c. balance	28
2. Adjusting the gain	28
B. General information	28
1. AC/0/DC switch	28
2. A/OFF/A-B switch	28
3. B/OFF/-B switch	29
4. ALT/CHOPP switch	29
5. GAIN switch	29
6. Triggering	29
a. General	29
b. Trigger coupling	29
c. Selecting the trigger source and setting the trigger level	30
d. Trigger polarity	30
e. Automatic triggering	30
7. Position SINGLE and use of the SET READY push-button	31
8. X MAGN switch	31
9. Use of the delayed time-base	31
10. External X deflection switch	31
11. Brightness modulation	31



VIII. Applications	32
A. Introduction	32
B. Voltage measurements	32
1. Peak-to-peak measurements	32
2. R.M.S. voltage measurements	33
3. Instantaneous voltage measurements	33
C. Time and frequency measurements	35
1. Introduction	35
2. Time measurements using the main time-base	35
3. Time difference measurements between two separate pulses using the main time-base	36
4. Time measurements using the delayed time-base	37
a. General information	37
b. Using the DELAY TIME MULTIPLIER	40
c. Using the graticule	40
5. Rise time measurements	40
a. General information	40
b. Rise time measurements using the main time-base	42
c. Rise time measurements using the delayed time-base	44
6. Phase difference measurements	45
a. General information	45
b. Phase difference measurements using the main time-base	45
c. Phase difference measurements using the delayed time-base	46
D. X-Y measurements	47
1. Introduction	47
2. Phase shift measurements	47
3. Frequency measurements	48
E. Differential measurements	48
1. Introduction	48
2. Differential measurements	48
3. Common mode rejection factor	48
F. Oscilloscope output signal applications	49
G. Photographic screen traces	49

## List of illustrations

### Fig.

IV-1	Block diagram	17
V-1	Rear view	21
VI-1	Front panel controls	26
VII-1	Scanning the waveform to be studied by means of the LEVEL potentiometer	30
VIII-1	Peak-to-peak voltage measurements	33
VIII-2	Instantaneous voltage measurements using the line written by channel Y <sub>B</sub> as a reference marker	34
VIII-3	Main time-base time measurement with one measuring point aligned with a vertical graticule and the other measuring point aligned with the horizontal centre-line	36
VIII-4	Separately displayed signals shifted so that one time difference measuring point passes through the junction formed by a vertical graticule line and the horizontal centre-line	37
VIII-5	Basic waveform	38
VIII-6	Intensified portion of basic waveform	38
VIII-7	Enlarged display of the intensified portion obtained by setting the X DEFL switch to DEL'D TB	38
VIII-8	Point P <sub>1</sub> aligned with the vertical centre-line of the graticule (DELAY TIME MULTIPLIER control reads 5.17)	38
VIII-9	Waveform shifted across the screen until point P <sub>2</sub> is aligned with the vertical centre-line of the graticule (DELAY TIME MULTIPLIER control reads 6.32)	38
VIII-10	Definition of rise time	41
VIII-11	Square wave pulse with one edge intensified for the purpose of rise time measurement	43
VIII-12	Enlarged display of the intensified edge which is obtained when the X DEFL switch is to DEL'D TB	44
VIII-13	Main time-base phase difference measurement with leading waveform displayed over exactly eight divisions	45
VIII-14	Phase difference display with the intensified portion located at a point where the two pulses cross the centre-line	47
VIII-15	Enlarged portion of the display with one measuring point shifted to its nearest vertical graticule line	47
VIII-16	Determining the common mode rejection factor	49

## I. Introduction

## GENERAL INFORMATION

The 02, 03, 03C, 03E and 04 versions of the PM 3250 oscilloscope have been designed for general laboratory applications. Each version features a dual channel d.c. to 50 MHz vertical deflection system, with a maximum sensitivity of 2 mV/div. This sensitivity may be increased to 200  $\mu$ V/div. at a bandwidth of 5 MHz. The drift which is inherent at these high sensitivities is extensively reduced by a feed-back system.

There are field effect transistors incorporated in the input stages, and power output sockets enable active measuring probes and other devices to be supplied.

During differential measurements, it is possible to display the differential signal and the channel B signal simultaneously. A signal delay line has been incorporated so that the leading edges of extremely fast signals may be displayed.

The PM 3250 is equipped with a main time-base and a delayed time-base, each of which contains a complete trigger unit. The delayed time-base enables detailed displays of complex signals to be made across the entire width of the screen. There is a single sweep facility incorporated in the main time-base circuit. The maximum horizontal deflection speed using the x5 magnifier is 10 ns/div.

The 03E and 04 versions of the oscilloscope is capable of providing an extremely high level of display intensity. This intensity is especially useful for writing very fast single shot or low repetition rate signals.

## II. Technical data

Properties expressed in numerical values with stated tolerances are guaranteed for nominal mains voltages. Numerical values without tolerances merely serve as a guide and represent the characteristics of an average instrument.

### VERTICAL AMPLIFIERS

two amplifiers (channels A and B), drift-compensated, d.c.-coupled

#### Display modes

signal A only  
 signal B or  $-B$  only  
 signal A and  $\pm B$  chopped at 600 kHz  
 signal A and  $\pm B$  alternate  
 signal (A-B) only  
 signal (A-B) and  $\pm B$  chopped\*  
 signal (A-B) and  $\pm B$  alternate\*

#### Bandwidth

*x1 mode*  
 DC: 0 Hz to 50 MHz, ( $-3$  dB)  
 AC: 3 Hz to 50 MHz, ( $-3$  dB)  
 Rise-time  $\leq 7$  ns

*x10 mode*  
 DC: 0 Hz to 5 MHz, ( $-3$  dB)  
 AC: 3 Hz to 5 MHz, ( $-3$  dB)  
 Rise-time 70 ns

#### Deflection factor

*x1 mode*  
 2 mV/div. to 20 V/div. in 13 calibrated steps (1, 2, 5 sequence)

*x10 mode*  
 200  $\mu$ V/div. to 2 V/div. in 13 calibrated steps (1, 2, 5 sequence)  
 Uncalibrated vernier permits continuous control 1:  $> 2.5$  between steps

#### Accuracy

*x1 mode*:  $\pm 3\%$  with respect to position 20 mV/div.  
*x10 mode*: additionally 2%

#### Input impedance

1 M $\Omega$ //20 pF

#### Input RC time

50 ms

#### Maximum input voltage

DC:  $\pm 400$  V  
 AC: 400 V<sub>p-p</sub>

#### Positioning range

*x1 mode*  
 3 times useful screen height (24 div.)

*x10 mode*  
 20 times useful screen height (160 div.)

#### Signal delay

Visible, 30 ns; total delay line 65 ns

#### Overshoot/undershoot of signal display

A and B: 2 %  
 (A-B) and  $-B$ : 5 %

Simultaneous display decoupling factor (see IEC 351) at 30 MHz,  
 2 mV/div. and 6 divisions disturbing voltage: Typically 4 %.

\*In these positions both signals (A-B) and B are displayed, so it is possible to display simultaneously the differential signal (A-B) and the signal on channel B.

Common-mode rejection factor:  
common-mode voltage, 800 mV and 20 mV/div.

*x1 mode*

50 Hz $\geq$ 400	} maximum permissible common-mode voltage 5x screen height
100 Hz 400	
5 MHz 40	
20 MHz $\geq$ 20	

*x10 mode*

50 Hz $\geq$ 400	} maximum permissible common-mode voltage 50x screen height
2 kHz 400	
1 MHz 100	

Maximum drift at maximum amplification:

Typical values at 200  $\mu$ V/div. after the instrument has been operating for half an hour under ambient room conditions:

Short-term measured over 1 min period	0.3 div.
Long-term measured over 1 hr period	0.5 div.
Long-term measured over 1 week	1.0 div.
Influence of temperature	0.2 div./ $^{\circ}$ C

Dynamic range for sine-wave signals:

Continuous control in position CAL

100 kHz $\geq$ 40 div.	} x1 mode
15 MHz $\geq$ 25 div.	
50 MHz $\geq$ 6 div.	
100 kHz $\geq$ 400 div.	} x10 mode
5 MHz $\geq$ 170 div.	

Displayed noise, tangentially measured, including periodic deviations (P.A.R.D.)

Source resistance 50 ohm

at 2 mV/div.	$\leq$ 0.1 div.
at 200 $\mu$ V/div.	$\leq$ 0.5 div.

Source resistance 10 megohm

at 2 mV/div.	0.2 div.
at 200 $\mu$ V/div.	0.5 div.

**CALIBRATION**

Calibration voltage

600 mV  $\pm$  1 %

Calibration current

6 mA (short-circuit)  $\pm$  2 %

Frequency

2 kHz  $\pm$  1 %

**HORIZONTAL AMPLIFIER**

(Deflection with external voltage via channel B; x-10 mode, beamfinder, and X magnifier inoperative).

Bandwidth

DC; 0 Hz to 5 MHz, (-3 dB)	} If channel A is used in the x10 mode, the bandwidth is reduced to 4 MHz (-3 dB)
AC: 3 Hz to 5 MHz, (-3 dB)	

Dynamic range	1 kHz : 8 div. 5 MHz: -3 dB
Overshoot	5 % with a rise-time of 100 ns
Input impedance	1 M $\Omega$ //20 pF
Input RC-time	50 ms
Maximum input voltage	DC: $\pm$ 400 V AC: 400 V <sub>p-p</sub>
Phase shift between X and Y amplifiers	$\leq$ 3° at 100 kHz
Deflection coefficient	2 mV/div. to 20 V/div. in 13 calibrated steps; uncalibrated vernier allows continuous control between steps
Polarity	positive or negative

### MAIN TIME-BASE

Sweep speeds	50 ns/div. to 1 s/div. in 23 calibrated steps (1, 2, 5 sequence); uncalibrated vernier allows continuous control (1: $\geq$ 2.5) between the steps.
Accuracy	$\pm$ 3 % measured over the middle eight div. for all ranges except 1 s/div., 0.5 s/div. and 0.2 s/div., which have a tolerance of $\pm$ 5 %. In the x5 position there is an additional tolerance of $\pm$ 2 %.
Positioning range	At x5 magnification the ends of the trace can be brought on to the screen by the X POSITION control
Modes	Triggered, automatic, single sweep
Magnification	x5 magnification of the X amplifier gain (maximum sweep speed is therefore 10 ns/div.) In the x5 position, the accuracy tolerance is additionally $\pm$ 2 %.

### TRIGGERING

Source	Internal channel A (or A-B), internal channel B or external
Slope	Positive or negative
Trigger coupling	LF : 3 Hz to 1 MHz, (-3 dB) HF : 2 kHz to > 75 MHz, (-3 dB) DC : 0 Hz to > 75 MHz, (-3 dB)
Trigger sensitivity	Internal : $\leq$ 0.5 div. up to 20 MHz $\leq$ 1.0 div. up to 50 MHz External: $\leq$ 0.5 V up to 20 MHz $\leq$ 1.0 V up to 50 MHz
Input impedance	1 megohm//20 pF. Same for the vertical channels so probe can be used both for measuring and triggering
Maximum input voltage	DC: $\pm$ 400 V AC: 400 V <sub>p-p</sub> permissible for 30 sec. only; 200 V <sub>p-p</sub> continuously.
Level range	Internal : position x1, 8 div. approx. position x5, 40 div. approx. External: position x1, 6 V approx. position x5, 30 V approx.

**DELAYED TIME-BASE**

Sweep speeds	50 ns/div. to 0.5 s/div. in 22 calibrated steps (1, 2, 5 sequence). Vernier permits continuous control (1: > 2.5) between the steps (uncalibrated).
Accuracy	±3 % measured over the middle 8 div. for all ranges except for positions 0.5 s/div., and 0.2 s/div., which have a tolerance of ±5 %. In the x5 position there is an additional tol. of ±2 %.
Magnification	x5 (maximum sweep speed is therefore 10 ns/div. due to the magnification of gain of X ampl.) In the x5 position, the accuracy tolerance is additionally ±2 %.
Positioning range	The ends of the trace can be brought on to the screen by the X POSITION control
Delay control	Incremental multiplier linearity typically 0.3 % measured at 1 ms/div. by main time-base. Delay-time jitter < 1: 20000 Initial delay time, typically 40 ns
Modes	Position STARTS: triggered by main sweep immediately after delay time Position TRIGG : triggered by measuring signal after delay time (applicable for jitter-free measurements). Position OFF : delayed time-base is switched off.

**MAIN TIME-BASE OUTPUT**

	Not protected against external voltages.
Sawtooth voltage	(Open-circuit) +8 V, base line 0 V
Output resistance	4.7 kΩ

**DELAYED GATE OUTPUT**

	Not protected against external voltages.
Square-wave gate voltage	(Open-circuit) +2 V, base line 0 V. Signal available only in position DEL'D TB of X DEFL. switch.
Output resistance	600 Ω

**DISPLAY**

Cathode ray tube	D14 – 160 GH/09, internal graticule with dotted calibration lines at 10 % and 90 %.
Useful screen area	8 cm x 10 cm
Phosphor	GH (P31)
Total acceleration voltage	10 kV
Graticule illumination	Continuously adjustable
Beamfinder	Push-button control for reducing the deflection sensitivity to display the signal within the screen area. Also resets the X magnifier to x1 position if in the x5 position.

**Z MODULATION**

Source	Internal or external.
Internal:	Brightness controlled by main time-base. Brightness controlled by main time-base intensified by delayed time-base Brightness controlled by delayed time-base In CHOPP position the beam is suppressed during switching
External:	Via an a.c. or d.c.-coupled input
Voltage for visible indication	5 V
Polarity	a.c.-coupled: negative to increase trace intensity d.c.-coupled: positive to increase trace intensity
Bandwidth	DC: 0 Hz to 5 MHz AC: 3 kHz to 50 MHz
Input impedance	DC: $1\text{ M}\Omega//20\text{ pF}$ AC: $50\ \Omega$

**POWER SUPPLY**

Mains voltages	<u>Nominal Voltage</u>	<u>Permissible Voltage Range*</u>
	110 V	100 V to 120 V
	125 V	117 V to 140 V
	SPEC (145 V)	133 V to 160 V
	200 V	184 V to 220 V
	220 V	200 V to 240 V
	245 V	217 V to 260 V
Power consumption	100 W approximately	
Mains frequency	46 Hz to 440 Hz	
Accessory power supply	+24 V d.c. } suitable for supplying Philips active accessories, e.g., - 24 V d.c. } PM 9352, PM 9347.	

**TEMPERATURE RANGE**

Operating within specification	0 °C to +45 °C
Operating range	-10 °C to +55 °C
Storage range	-40 °C to +70 °C
	(These temperature ranges comply with IEC Standard 68)

**PHYSICAL**

Overall Dimensions	Height	24.5 cm
	Width	34.0 cm
	Depth	53.5 cm
Weight	18.5 kg (40 lb) approximately	

\* Measured at 50 Hz and with a distortion that reduces the peak voltage by less than 5 %.



### III. Accessories

The oscilloscope is supplied complete with the following accessories:

- A manual
- Two adaptors, BNC to 4 mm (PM 9051)
- A trimming rod
- An additional green contrast plate
- Collapsible viewing hood (PM 9366)

The following items are also available as optional accessories:

- |                                    |         |
|------------------------------------|---------|
| - Current loop                     | PM 9040 |
| - HF 10:1 probe                    | PM 9350 |
| - HF 1:1 probe                     | PM 9335 |
| - Miniature probe                  | PM 9352 |
| - Adaptor for rack mount           | PM 9364 |
| - Polaroid oscilloscope camera set | PM 9380 |
| - TV probe                         | PM 9347 |
| - Supplementary lens for PM 9380   | PM 9373 |
| - Camera adaptor                   | PM 9376 |
| - Carrying case                    | PM 9394 |
| - Trolley                          | PM 9395 |

## IV. Description of the blockdiagram

### A. GENERAL

The oscilloscope PM 3250 consists of the following parts:

- a dual channel vertical system
- Main time-base
- Delayed time-base
- a horizontal amplifier
- an unblanking circuit
- a cathode ray tube circuit
- a stabilised power supply
- a calibration voltage generator

### B. DUAL CHANNEL VERTICAL SYSTEM

This dual channel vertical system contains the following components:

- An "AC/O/DC" switch by means of which the coupling of the input signal can be selected.
- A step attenuator controlled by switch "AMPL" enables the adjustment of the vertical deflection sensitivity in calibrated steps.
- A FET source follower giving the circuit a high input impedance
- A pre-amplifier
- An emitter follower adapting the pre-amplifier to the next stage.  
By means of potentiometer "AMPL", the vertical deflection sensitivity can be continuously controlled. From the emitter follower the signal is distributed to:
  - the intermediate amplifier
  - the trigger pick-off stage
  - the drift reduction circuit
- A drift reduction circuit which senses the input voltage and a part of the output voltage of the pre-amplifier to determine the drift voltage originated in the pre-amplifier. After amplification, this drift voltage is fed back to the second input of the pre-amplifier. In this way the overall drift is strongly reduced.
- An amplifier which further amplifies the signal. By means of the "Y POSITION" control the trace can be shifted in vertical direction. When switch "A/OFF/A-B" is in position "A-B", the signal of channel B is also applied to the amplifier of channel A so that the difference between the signals of channel A and B will be displayed.
- An electronic switch which either blocks or passes the signal, depending on the position of the multivibrator.
- Channel B has been provided with a signal polarity inverter, operated with switch "B/OFF/-B".
- A driver stage for the electronic switches, consisting of a bistable multivibrator and a blocking oscillator. In position "CHOPP" of switch "CHOPP/ALT" the blocking oscillator works at a fixed frequency and the electronic switches are successively opened and closed so that successively part of the signal of channel A and part of the signal of channel B are displayed. In position "ALT" the blocking oscillator is not oscillating and is driven by the flyback signals from the main time-base generator, so that alternately the complete signals of channel A and channel B are displayed. In position "OFF" of switch "A/OFF/A-B" the signal of channel A is blocked by the electronic switch. In position "OFF" of switch "B/OFF/-B" the signal of channel B is blocked. When switch "X DEFL" is in position "EXT via Y<sub>B</sub>", the signal of channel B is applied to the horizontal output amplifier via the electronic switch and a gate circuit.

- After the electronic switches, the circuits are common to both vertical channels. These circuits are:
- An amplifier stage which contains two switches:
  - the "GAIN" switch by means of which the deflection sensitivity of both channels can be increased by a factor 10;
  - the "BEAMFINDER" switch by means of which the deflection sensitivity can be reduced to such an extent that the signal is always displayed within the screen.
- A delay-line driver stage.
- A delay-line that delays the vertical signals to such an extent that the steep leading edges of fast signals are still displayed.
- An output amplifier which feeds the signals to the vertical deflection plates.

### C. TIME-BASES

The main and delayed time-bases contain the following circuits:

- A common trigger pick-off stage that amplifies the signals coming from the vertical channels A and B, and deliver them to the trigger units. In position "A-B" of switch "A/OFF/A.B", it supplies the signal A-B instead of signal A.
- An "Y<sub>A</sub>/Y<sub>B</sub>/EXT" switch by means of which the trigger signal source can be selected.
- A "LF/HF/DC" switch by means of which two working modes of the delayed time-base generator can be selected, viz:
  - position "STARTS": The delayed time-base generator starts immediately after the delay time.
  - position "TRIGG": The delayed time-base is triggered - after the delay time - by the pulses coming from its trigger unit.
- When the "X DEFL" switch is in the position "MAIN TB", that part of the trace coinciding with the delayed sweep is intensified, except in the "OFF" position of the delayed "TIME/div" switch.

### D. HORIZONTAL AMPLIFIER

This amplifier serves for amplifying one of the internal sawtooth voltages or the signal of vertical channel B (depending on the position of the switch "X DEFL"), before this is applied to the horizontal deflection plates.

This circuit contains also:

- A "X POSITION" control by means of which the trace can be shifted in horizontal direction (not operating in position "EXTERN via Y<sub>B</sub>")
- A "X MAGN" control by means of which the horizontal amplification can be increased by a factor 5 (not operating in position "EXTERN via Y<sub>B</sub>")
- A "BEAMFINDER" switch by means of which the deflection sensitivity can be reduced to such an extent that the signal is always displayed within the screen.

### E. OTHER UNITS

The PM 3250 contains also the following units:

- An unblanking circuit with a DC and an AC input.
- A cathode-ray tube circuit with an "INTENSITY" and a "FOCUS" control.
- A stabilised power supply which delivers the supply voltages both for the circuits and for the cathode-ray tube.
- A calibration unit.

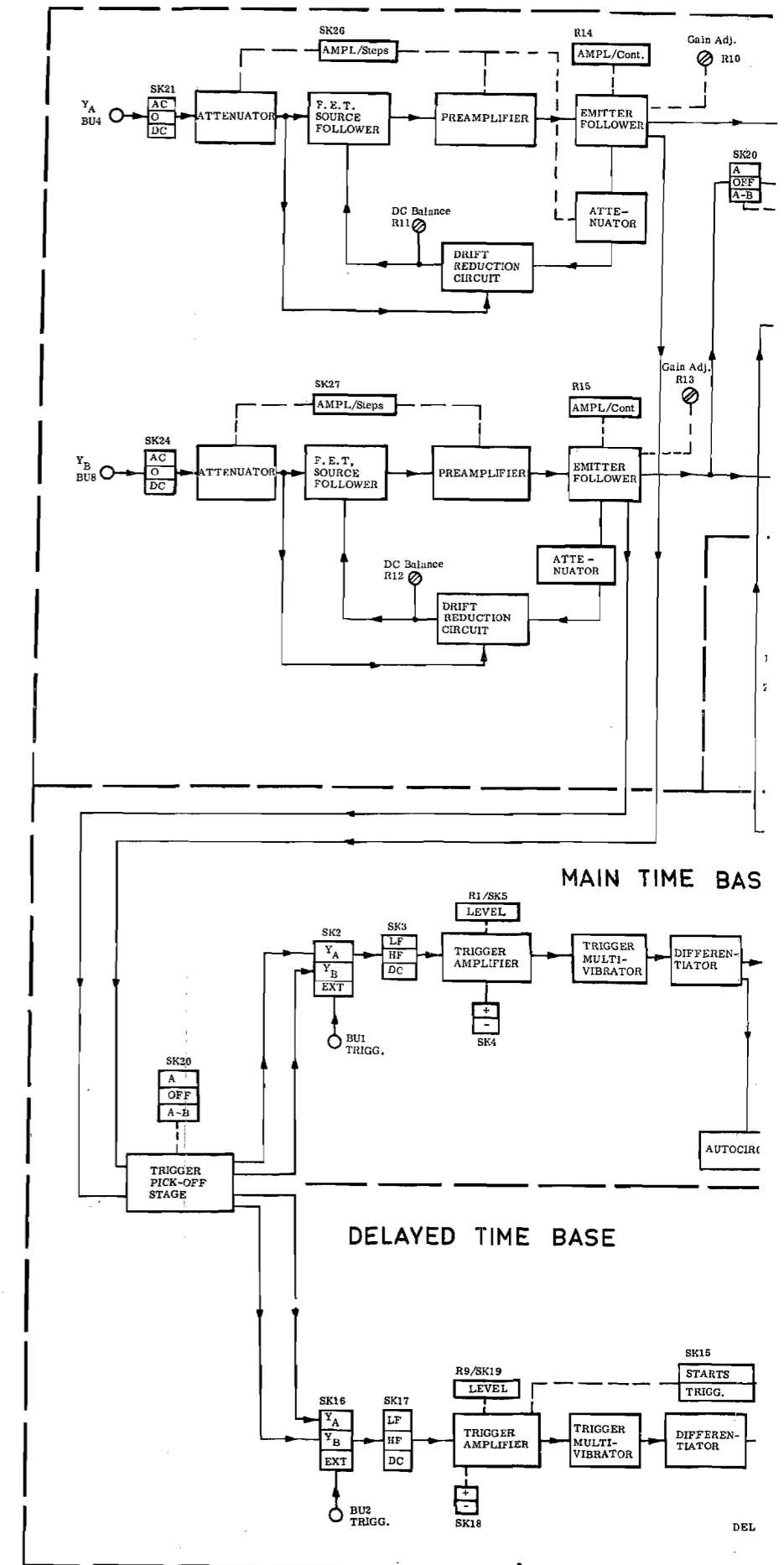

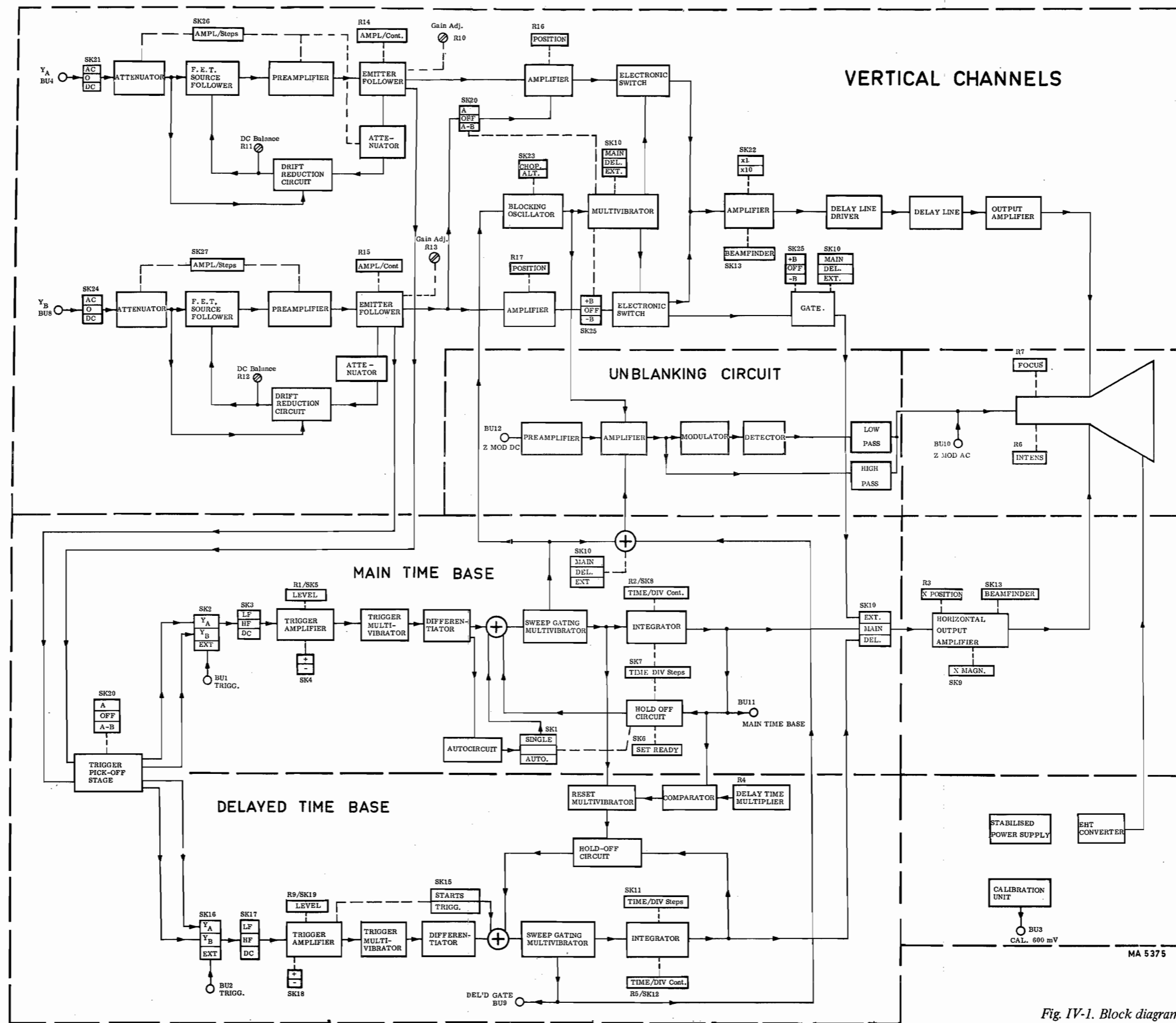

Fig. IV-1. Block diagram

## V. Installation

## DIRECTIONS FOR USE

### A. MAINS ADJUSTMENT AND FUSES

Before connecting the oscilloscope to the supply, set its voltage adaptor to suit the local mains voltage. The voltage adaptor, which is located on the rear panel of the oscilloscope, provides means by which nominal mains voltages of 110 V, 125 V, 145 V (SPEC), 200 V, and 240 V may be selected. The voltage to which the adaptor has been set is shown through a hole in the cover plate.

The fuse holder which is mounted on the rear panel normally carries a 1 A fuse, but a 2 A fuse should be fitted if the oscilloscope is to be connected to a mains voltage of less than 200 V.

Check that the fuse is of the specified type and current rating before connecting the oscilloscope to the mains. The use of repaired fuses and the short-circuiting of fuse holders is prohibited.

### B. EARTHING

In the interests of safety, the oscilloscope must be connected to earth via either the front or rear earthing terminal (identified by the symbol  $\perp$ ) or via the mains lead, provided that the supply socket is equipped with an earth connection. Care must be taken that the earth line to the oscilloscope is not interrupted due to the use of an extension lead or device which is not fitted with an earth conductor. Double earthing must be avoided because this gives rise to hum.

### C. SWITCHING ON

Ensure that the oscilloscope is set to the nominal value of the mains supply before it is switched on. The POWER ON switch is located, together with an associated indicator lamp, on the front panel immediately beneath the screen bezel.

The oscilloscope must never be switched on whilst any circuit board has been removed.

Never remove a printed wiring board until at least one minute after the oscilloscope has been switched off.

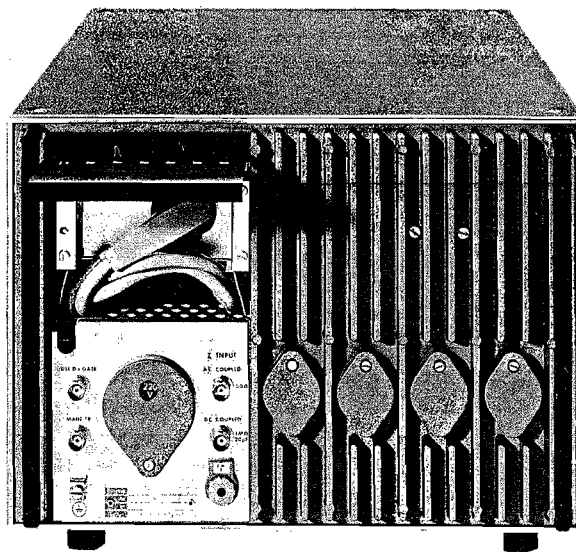

*Fig. V-1. Rear view*

## VI. Knobs, sockets and their functions

### MAIN TIME-BASE

AUTO/TRIGG/SINGLE	Mode switch with three positions: <b>AUTO</b> : the main time-base is free running in absence of trigger signals <b>TRIGG</b> : the time-base is normally triggered. <b>SINGLE</b> : the time-base runs only once.
Y <sub>A</sub> /Y <sub>B</sub> /EXT	Choice of the trigger source: <b>Y<sub>A</sub></b> : Triggering on the signal fed to channel A or on the differential signal in position A-B of switch A/OFF/A-B. <b>Y<sub>B</sub></b> : Triggering on the signal fed to channel B. <b>EXT</b> : Triggering on a signal connected to socket TRIGG.
LF/HF/DC	Choice of the trigger coupling: <b>LF</b> : via a band-pass filter for frequencies between 3 Hz and 1 MHz <b>HF</b> : via a high-pass filter for frequencies higher than 2 kHz <b>DC</b> : triggering signals are direct-coupled.
+/-	Choice of triggering on the positive- or negative-going edge of the triggering signal.
LEVEL	Adjusting the triggering level.
PULL FOR x5	The level range can be increased 5x by means of this pull-push switch.
SET READY	If switch AUTO/TRIGG/SINGLE is in the SINGLE position, the time-base runs once after pressing the SET READY button upon receipt of a trigger pulse.
TIME/div. OR DELAY TIME	Control in steps of the time coefficient of the main time-base.
TIME/div. - CAL (red)	Continuous control of the time coefficient of the main time-base. In the position CAL, the time coefficient is calibrated.
TRIGG 1 MΩ//20 pF	BNC input socket for external triggering.

### HORIZONTAL AMPLIFIER

X POSITION	Horizontal positioning of the display, except in pos. EXTERN via Y <sub>B</sub> of switch X DEFL.
X MAGN PULL FOR x5 (red)	5x increase of the horizontal deflection coefficients by means of a pull-push switch.
MAGN. ON	Pilot lamp which lights up when the X MAGN switch is in the x5 position.
X DEFL	Selector switch with three positions: <b>MAIN TB</b> : The horizontal deflection voltage is supplied by the main time-base. A part of the trace is (except in position OFF of the delayed TIME/div. switch) intensified. <b>DEL'D TB</b> : The horizontal deflection voltage is supplied by the delayed time-base. <b>EXTERN via Y<sub>B</sub></b> : The horizontal deflection voltage is supplied by an external source via the vertical B channel.

**DELAYED TIME-BASE**

DELAY TIME MULTIPLIER	Control of the delay time in combination with the TIME/div. controls of the main time-base.
AFTER DELAY TIME	Choice of the start point of the delayed time-base after the delay time: TRIGG : The delayed time-base is started, after the delay time, only when a trigger pulse is received. STARTS: The delayed time-base is started immediately after the delay time.
Y <sub>A</sub> /Y <sub>B</sub> /EXT	Choice of the trigger source: Y <sub>A</sub> : Triggering on the signal fed to channel A or on the differential signal in position A-B of switch A/OFF/A-B. Y <sub>B</sub> : Triggering on the signal fed to channel B. EXT : Triggering on signal connected to socket TRIGG.
LF/HF/DC	Choice of the trigger coupling: LF : via a band-pass filter for frequencies between 3 Hz and 1 MHz. HF : via a high-pass filter for frequencies higher than 2 kHz. DC : triggering signals are coupled directly.
TIME/div.	Control in steps of the time coefficients of the delayed time-base. In the position OFF the delayed time-base is switched off.
TIME/div. -CAL (red)	Continuous control of the time coefficients of the delayed time-base. In the position CAL, the time coefficient is calibrated.

**TRIGG**

1 M $\Omega$ //20 pF +/-	BNC input socket for external trigger voltage. Choice of triggering on the positive- or negative-going edge of the trigger signal.
LEVEL	Adjustment of the trigger level.
PULL FOR x5	By means of this pull-push switch, the LEVEL range can be increased 5x.

**VERTICAL CHANNELS**

GAIN x1-x10	Selector switch with two positions: x1 : The vertical deflection coefficients have the values as indicated on the front panel. x10: The vertical deflection coefficients indicated on the front panel are reduced by a factor of ten. the bandwidth is limited to 5 MHz.
ALT/CHOPP	ALT : The display is switched over from one vertical channel to the other at the end of the main time-base signal. CHOPP : The display is switched over from one vertical channel to the other at a fixed frequency.
	Earth socket.

**CHANNEL A**

A/OFF/A-B

Selector switch with three positions:

A : The signal connected to channel A is displayed on the screen.

OFF : The signal connected to channel A is not displayed on the screen (but remains available for internal triggering).

A-B : The difference between the signals connected to channel A and to channel B is displayed on the screen. (Differential position).

POSITION

Vertical positioning of the display.

GAIN ADJ.

Screwdriver adjustment of the gain of the pre-amplifier of channel A, see section VII-A.

AMPL.

Control in steps of the vertical deflection coefficients.

AMPL – CAL (red)

Continuous control of the vertical deflection coefficients.

In the position CAL, the deflection coefficients are calibrated.

DC BAL

Screwdriver adjustment of the direct voltage balance of the Y amplifier of channel A, see section VII-A.

AC-0-DC

Selector switch with three positions:

AC : Connection between input socket and input circuit via a blocking capacitor.

0 : Connection between input socket and input circuit is interrupted, and the input circuit is earthed.

DC : Direct connection between the input socket and the input circuit.

1 M $\Omega$ //20 pF

BNC input socket for channel A.

PROBE POWER

Power supply socket for active accessories.

**CHANNEL B**

B/OFF/-B

Selector switch with three positions:

B : The signal connected to channel B is displayed on the screen.

OFF : The signal connected to channel B is not displayed on the screen (but remains available for integral triggering).

-B : The signal connected to channel B is displayed inverted on the screen.

POSITION

Vertical positioning of the display.

GAIN ADJ.

Screwdriver adjustment of the gain of the pre-amplifier of channel B, see section VII-A.

AMPL.

Control in steps of the vertical deflection coefficients.

AMPL – CAL (red)

Continuous control of the vertical deflection coefficients. In the position CAL, the deflection coefficients are calibrated.

DC BAL

Screwdriver adjustment of the direct voltage balance of the Y amplifier of channel B, see section VII-A.

AC-0-DC

Selector switch with three positions:

AC : Connection between input socket and input circuit via a blocking capacitor.

0 : Connection between input socket and input circuit is interrupted, and the input circuit is earthed.

DC : Direct connection between the input socket and the input circuit.

1 M $\Omega$ //20 pF

BNC input socket for channel B.

PROBE POWER

Power supply socket for active accessories.



**CATHODE RAY TUBE**

INTENS	Brightness control of the trace.
FOCUS	Focusing of the electron beam.
ILLUM	Continuous control of the graticule illumination.
BEAMFINDER	A push-button control for decreasing the deflection coefficients to such an extent that signal traces are entirely visible on the screen.

**CALIBRATION**

CAL	BNC output socket on which a square-wave voltage of 600 mV with a frequency of 2 kHz is available. Ri = 100 $\Omega$ The output can be s/c to obtain a calibration current of 6 mA (PM 9040).
-----	---

**REAR SIDE OF THE INSTRUMENT**

DEL.D. + GATE	BNC output socket on which the delayed gate pulses of +2 V are available.
MAIN TIME-BASE	BNC output socket on which the sawtooth voltage (0 to 8 Volt) of the main time-base is available.
	Earth socket.

**Z INPUT**

D.C. COUPLED (1 M $\Omega$ //20 pF)	d.c. input for modulating the trace brightness.
A.C. COUPLED (50 $\Omega$ )	a.c. input for modulating the trace brightness.

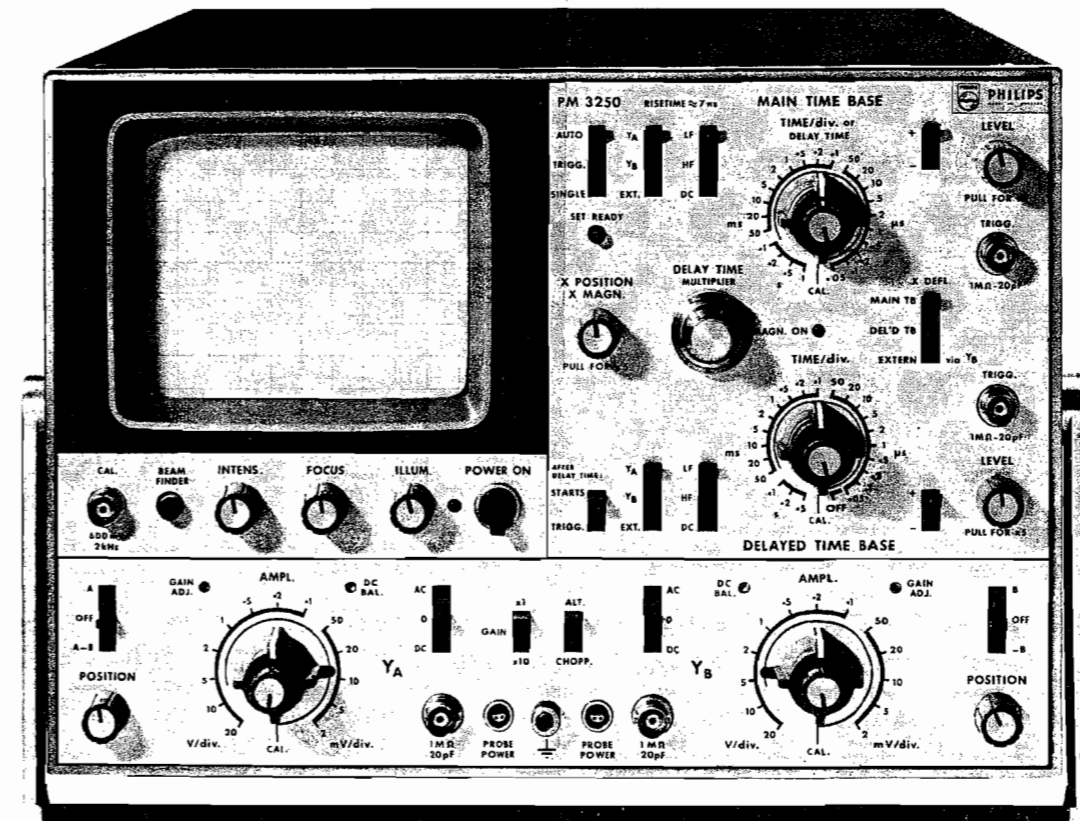

Fig. VI-1. Front panel controls

## VII. Operation

### A. PRELIMINARY SETTINGS

As the following settings are identical for both channels, only the procedure for channel A has been indicated.

#### 1. Adjusting the DC balance

- Set switch A/OFF/A-B to position A.
- Set switch AC/0/DC to position 0.
- Set switch AUTO/TRIGG/SINGLE to position AUTO.
- Set GAIN switch to position x1.
- Set GAIN switch to position x1.
- Set AMPL switch to position 2 mV/div.
- Centre the trace by means of POSITION potentiometer.
- Rotate continuous control AMPL to and from between maximum and minimum positions. At the same time adjust the DC BAL control until changes in the AMPL continuous control setting no longer cause the trace to be displaced.
- Set switch GAIN to position x10 and readjust, if necessary.

#### 2. Adjusting the gain

- Set switch AC/0/DC to position DC.
- Set switch GAIN to x1 position.
- Connect the CAL socket to the Y<sub>A</sub> input socket.
- Set switch AMPL to position 0.1 V/div. and the continuous control to position CAL.
- Check that the trace height is exactly 6 divisions.  
If necessary, adjust with potentiometer GAIN ADJ.

### B. GENERAL INFORMATION

#### 1. AC/0/DC switch

The signals under observation are fed to the input sockets Y<sub>A</sub> and/or Y<sub>B</sub>, and switch AC/0/DC is set to either AC or DC depending upon the composition of the signal.

As the Y amplifier is d.c.-coupled, the full bandwidth of the instrument is available and d.c. components are displayed as trace shifts in the DC position of the AC/0/DC switch. This may be inconvenient when signals superimposed on high d.c. voltages have to be displayed. Any attenuation will result in attenuation of the a.c. signals.

The remedy is to use the AC position of the switch, which employs a blocking capacitor, to suppress the d.c. and low frequency signals (0 Hz to 3 Hz, –3 dB; with 10:1 probe, 0 Hz to 0.3 Hz). Some pulse droop will occur when low frequency, square-waves are displayed.

The 0 position interrupts the signal and earths the amplifier input for quickly determining the 0 V level.

#### 2. A/OFF/A-B switch

When the switch is in position A, the signals applied to channel A are displayed in such a way that positive-going input signals cause an upward deflection on the screen.

In the OFF position the electronic switch of channel A is blocked, so that no input signal is fed to the output amplifier. It is, however, possible to use channel A for trigger purposes.

The intermediate amplifier of channel A is made differential. In position A of the A/OFF/A-B switch, one input is earthed. In position A-B, the differential mode, this earth is removed and the input signal of the channel B intermediate amplifier applied to this input.

Thus the difference of the signals of channels A and B will be displayed.

At the same time the signal of channel B, normal or inverted depending on the position of the B/OFF/-B switch, can be displayed. The position of this switch does not affect the signal which is applied to the differential amplifier, as this signal is taken off before.

For triggering in the differential mode, refer to the relevant section B.6.c.

### 3. B/OFF/-B switch

When this switch occupies position B, the signals applied to channel B are displayed in such way that positive-going input signals produce an upward deflection on the screen.

In the OFF position, the electronic switch of channel B is blocked, so that no input signal is fed to the output amplifier. It is, however, possible to use channel B for trigger purposes.

In position -B, the signals applied to channel B are displayed in such way that positive-going input signals produce a downward deflection on the screen.

### 4. ALT/CHOPP switch

In the ALT position, the display is switched over from one channel to the other at the end of the linear part of the sawtooth of the main time-base.

In position CHOPP, the display is switched over from one channel to the other with a fixed frequency.

### 5. GAIN switch

In position x10 of this switch, the sensitivity of both vertical channels is increased by a factor 10.

The bandwidth in this position is limited to 5 MHz.

An important advantage in this position is also that the positioning range of the POSITION potentiometers is increased from 24 divisions to 160 divisions\*, as the GAIN switch is incorporated in the circuit after the position controls.

Example:

A deflection factor of 20 mV/div. can be obtained by setting the AMPL switch to position 20 mV/div., or by setting the AMPL switch to position .2 V/div. and the GAIN switch to position x10.

In the former case the positioning range is 24 divisions and in the latter case 160 divisions, however with reduced bandwidth. Where very small signals, superimposed on large signals are to be examined, the second possibility is very useful as long as the limited bandwidth is not unacceptable.

## 6. Triggering

### a. General

If a signal must be displayed, the horizontal deflection must always be started on one fixed point of the signal in order to obtain a stationary picture. The time-base is, therefore, started by narrow trigger pulses formed in the trigger unit, controlled by a signal originating from one of the vertical input signals or an external source.

### b. Trigger Coupling

Three different trigger coupling methods can be chosen with switch LF/HF/DC. The LF and HF positions limit the transfer characteristic.

In position LF, a 3 Hz to 1 MHz band-pass filter is inserted. This position can be used to reduce interference from noise.

In position HF, a 2 kHz high-pass filter is inserted. This position can be used to reduce interference from, e.g. hum.

In position DC, finally, the trigger signal is passed unchanged.

\* 8 divisions of the graticule and each 8 divisions "above" and "below" the graticule. In position x10 one obtains 10x8 divisions "above" as well as "below" the graticule.

### c. Selecting the trigger source and setting the trigger level

The trigger signal is obtained from channel A (position  $Y_A$ ), channel B (position  $Y_B$ ), or from an external source (position EXT), depending on the position of switch  $Y_A/Y_B/EXT$ . In the differential position of the vertical amplifier, the trigger signal received from channel A is the difference signal, not affected by the AMPL. continuous control.

The trigger pulse shaper is a dual-controlled multivibrator switched by the output signals of a difference amplifier.

The trigger signal is fed to one input of the difference amplifier; and a direct voltage adjustable with the LEVEL potentiometer is fed to the other input. Depending on this LEVEL setting, the selected part of the trigger signal will be amplified by means of the difference amplifier; and the multivibrator is thus switched at a fixed point of the trigger signal (see Fig. VII-1). This means that, with the aid of the LEVEL control, it is possible to scan the shape of the trigger signal (in case of internal triggering, equal to the shape of the signal to be displayed), and thus to choose the point where the multivibrator will be switched.

The LEVEL potentiometer is fitted with a pull-push switch which allows a 5-fold range increase to be used for large trigger signals.

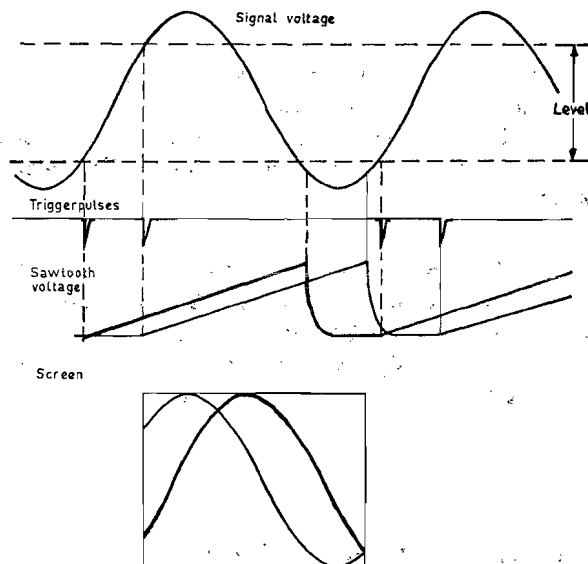

Fig. VII-1. Scanning the waveform to be studied by means of the LEVEL potentiometer

### d. Trigger polarity

With the aid of trigger polarity switch  $+/-$ , triggering is possible, chosen on the positive-going or negative-going edge of the trigger signal.

### e. Automatic triggering

When the switch AUTO/TRIGG/SINGLE is in the position AUTO, and if there are no trigger pulses available, the time-base generator is automatically free-running. The trace is, therefore, always visible. This position can be used in all cases where also TRIGG is usable except with reference frequencies lower than 2 Hz. As soon as trigger pulses are available, the free-running state of the time-base is automatically terminated and the time-base is triggered again, as described in points b, c, d. In the positions TRIGG and SINGLE, the auto-circuit is switched off. The LEVEL setting can also be used in position AUTO of switch AUTO/TRIGG/SINGLE.

## 7. Position SINGLE and use of the SET READY push-button

When effects which occur only once have to be observed (usually photographed), it is often desirable to ensure that only sawtooth is generated, even though several trigger pulses might be produced after the phenomenon of interest. Of course, the single sawtooth in question must be triggered by a trigger pulse. To this end the mode switch must be put into position SINGLE. When the SET READY button has been pressed, the first following trigger pulse that appears after this button has been released will start the time-base generator. The trace is only written once. The time-base is then blocked until the SET READY push-button is again operated.

The lamp in the SET READY push-button, will light up as soon as this button is released and will go out as soon as the sawtooth is terminated.

## 8. X MAGN switch

The X MAGN switch is a two-position pull-push type.

In position x5, the horizontal deflection is increased by a factor of 5, except when X DEFL switch is in EXTERN via YB position. Thus the portion of the signal displayed in the two central horizontal divisions in the x1 position, occupies the full width of the screen in the x5 position. Any portion of the trace can be brought on to the screen by the X POSITION control for scrutinisation.

In the x5 position, the sweep time of the sawtooth is determined by dividing the indicated TIME/div. value by 5.

## 9. Use of the delayed time-base

The delayed time-base can be used for accurate time measurements, (see Chapter VIII-C4) and for the accurate study of complex signals.

In the STARTS position of the AFTER DELAY TIME switch, immediately the delayed time-base is on i.e., (TIME/div. switch is not at OFF), a portion of the displayed signal is intensified in the MAIN TB position of the X DEFL switch. The DELAY TIME MULTIPLIER enables this intensified portion to be shifted along the time axis. The duration of the intensified portion, its length, can be controlled in steps and also continuously, by the TIME/div. controls of the delayed time-base. When the X DEFL switch is in the DEL'D TB position, the intensified portion occupies the full width of the screen.

In the DEL'D TB position of the X DEFL switch, the product of the main TIME/div. switch setting and the setting of the DELAY TIME MULTIPLIER determines the delay time; i.e., the interval between the starting point of the main time-base and the starting point of the delayed time-base.

In the TRIGG position of the AFTER DELAY TIME switch, the delayed time-base is started by the first trigger pulse that occurs after the selected delay time.

This trigger pulse is supplied by the trigger unit of the delayed time-base. This position is used when time jitter would otherwise give a blurred image of the detail under observation. This time jitter could be part of the signal being investigated or, at extreme magnifications, initiated by the time-base circuits.

## 10. External X deflection

If switch X DEFL is in the EXTERN via YB position, both time-bases will be switched off. The signal of channel B is horizontally displayed, over a bandwidth of 5 MHz.

Except for the GAIN switch, all controls of channel B remain operative.

The X POSITION and X MAGN controls are switched off; for positioning the trace the POSITION control of the B channel is employed.

## 11. Brightness modulation

To obtain extra information on a display without changing its waveform, the brightness can be modulated by an external voltage.

The external voltage must be fed to one of the Z MOD sockets at the rear of the instrument. The amplitude required to achieve visible brightness modulation depends on the position of the INTENS potentiometer. With normal picture brightness, a 5 V<sub>p-p</sub> amplitude is able to obtain good visible brightness modulation.

Two input sockets are available, a high impedance DC COUPLED socket and a low impedance AC COUPLED socket.

## VIII. Applications

### A. INTRODUCTION

The following information describes the basic measuring techniques for use with the PM 3250 oscilloscope. Before connecting an input to the oscilloscope, locate the beam as follows:

- Connect the apparatus to the mains and switch on
- Set all switches to their upper positions and all potentiometers to their mid positions
- Use the BEAMFINDER push-button in conjunction with the POSITION controls to display the beam. Optimum graticule and waveform display conditions can then be set using the INTENS, FOCUS, and ILLUM controls. Maximum accuracy is obtained by setting up a waveform which is as large as possible. Whenever a reading is taken from an AMPL or TIME/div. control, it is important that the associated potentiometer is in its CAL position, otherwise the switch setting will not have the exact value shown on the calibrated scale.

When the GAIN switch is set to x10, the bandwidth of the oscilloscope is limited to 5 MHz and sensitivity is increased by a factor of 10. Maximum sensitivity is 200  $\mu\text{V}/\text{div}$ .

Operation of an 03E/04 oscilloscope with its INTENS control set to the maximum position will involve an increase in the specified horizontal and vertical gain tolerances of up to +2 %.

### B. VOLTAGE MEASUREMENTS

#### i. Peak-to-peak measurements

- Connect the signal to the  $Y_A$  input socket
- Set the GAIN switch to x1
- Set the AC/0/DC switch of channel A to AC (or to DC if the signal under examination has a frequency of less than 10 Hz)
- Set the A/OFF/A-B switch to A, and the B/OFF/-B switch to OFF
- Set the AUTO/TRIGG/SINGLE switch to AUTO
- Set the  $Y_A/Y_B/\text{EXT}$  switch to  $Y_A$
- Set the HF/LF/DC switch to the appropriate position, depending upon the frequency of the signal
- Set the X DEFL switch to MAIN TB
- Set the AMPL potentiometer to its CAL position. Do not disturb this setting until the measurement procedure has been completed
- Use the POSITION control of channel A to shift the trace until it is written symmetrically about the horizontal centre-line of the graticule
- If necessary, use the X POSITION control to centre the signal
- Obtain the largest possible display using the AMPL switch of channel A
- With the TIME/div. switch of the delayed time-base set to OFF, set the TIME/div. switch of the main-time base to a position at which several cycles of the signals can be seen. If necessary, adjust the main time-base LEVEL control in order to obtain a stable trace
- Using the POSITION control of channel A, align the upper peaks of the waveform with the nearest horizontal graticule line, as shown in Fig. VIII-1.
- Align one of the lower peaks with the vertical centre-line of the graticule.
- Measure the height of the waveform using the graduations of vertical graticule line
- Multiply the distance obtained by the deflection coefficient at which the AMPL control is set, and by the attenuation factor of the probe (if any) in order to obtain the peak-to-peak value of the waveform.

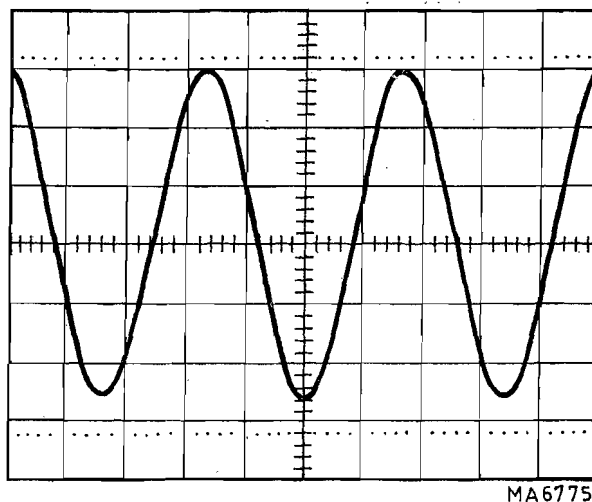

Fig. VIII-1. Peak-to-peak voltage measurement, with one lower peak aligned with the vertical centre-line and the upper peaks aligned with a horizontal graticule line

## 2. R.M.S. voltage measurements

The r.m.s. value of a sinusoidal waveform may be found as follows:

- Determine the peak-to-peak value of the waveform using the method described in the above paragraph
- Calculate the r.m.s. value by inserting the peak-to-peak value in the formula quoted below:

$$V_{\text{r.m.s.}} = \frac{V_{\text{p-p}}}{2\sqrt{2}} \approx 0.35 V_{\text{p-p}}$$

## 3. Instantaneous voltage measurements

The following procedure can be used to measure instantaneous voltage:

- Connect the signal to the  $Y_A$  input socket
- Set the A/OFF/A-B switch to A and the B/OFF/-B to OFF
- Set the AUTO/TRIGG/SINGLE switch to AUTO
- Set the  $Y_A/Y_B/EXT$  switch to  $Y_A$
- Set the LF/HF/DC switch to the appropriate position, depending upon the frequency of the input signal
- Use the POSITION control of channel A to display the signal about the horizontal centre-line
- If necessary, place the signal by means of the X POSITION control
- Turn the AMPL potentiometer of channel A to its CAL position.  
Do not disturb this setting until the measuring procedure has been completed
- Set the AMPL switch of channel A to the position at which the largest possible display is obtained
- Set the AC/0/DC switches of both channels to '0'. The trace becomes linear
- Using the  $Y_A$  POSITION control, align the trace with a suitable horizontal graticule line. This horizontal graticule line will become the reference level, so that it should be located in a position to suit the waveform which is displayed when the AC/0/DC switch of channel A is set to DC.
- Set the B/OFF/-B switch to B in order to display a second horizontal trace which may be used to illuminate the graticule chosen as the reference level
- Use the  $Y_B$  channel POSITION control to align the two horizontal traces. Note that it is important to use the  $Y_B$  POSITION control for alignment of the two traces

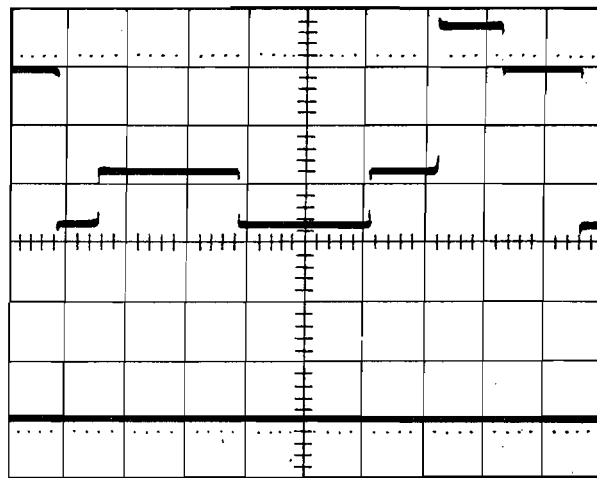

MA6776

Fig. VIII-2. Instantaneous voltage measurement using the line written by channel  $Y_B$  as a reference marker

- Set the AC/0/DC switch of channel A to DC. The waveform will now be displayed, together with the horizontal line which marks the reference level. It is extremely important not to disturb the POSITION switches of the two channels, otherwise the true reference level may be lost.
- Adjust the main time-base LEVEL control in order to obtain a stable display
- With the TIME/div. switch of the delayed time-base set to OFF, set the main time-base TIME/div. switch to a position which provides a suitable display
- Use the X POSITION control to align the instantaneous voltage point which has to be measured, with the vertical centre-line of the graticule, as shown in Fig. VIII-2.
- Record the number of divisions that separate the instantaneous voltage point from the reference line
- Prior to the conclusion of the measurement it is advisable to check the accuracy of the reference level by setting the AC/0/DC switch of channel A to 0. If the reference level is correct, the two horizontal traces should merge so that they appear to be one line on the display. If this is not the case, repeat the whole measurement procedure

The value of the instantaneous voltage may be calculated by multiplying the vertical distance between the instantaneous voltage point and the reference level, by the deflection coefficient to which the AMPL switch has been set, and by the attenuation factor of the probe (if used). If the instantaneous voltage point appears above the reference line, it is positive: negative potentials are displayed below the reference line

If an instantaneous voltage is to be measured with respect to a second (reference) voltage, proceed as follows:

- Connect and set up the signal as described in the first nine steps of the above procedure
- Temporarily disconnect the signal from the  $Y_A$  input socket and connect the reference signal
- Align the reference level with a suitable horizontal graticule line
- Set the B/OFF/-B switch to B in order to display a horizontal trace which may be used to mark the reference level. Use the  $Y_B$  channel POSITION control to align the two traces.
- Disconnect the reference signal. Note that, since the reference signal has been disconnected, there is no easy means by which the reference level displayed by channel B can be checked. It is, therefore, most important that the POSITION controls of both channels are not disturbed until the measurement procedure has been completed



- Reconnect the signal to the  $Y_A$  input socket
- Calculate the voltage value by multiplying the vertical distance between the instantaneous voltage point and the reference level by the deflection coefficient to which the AMPL switch is set, and by the attenuation factor of the probe (if used)

## C. TIME AND FREQUENCY MEASUREMENTS

### 1. Introduction

The following section describes those techniques employed to evaluate time differences between signals, and to establish the frequency of a displayed waveform. Two waveforms can only be displayed in a manner suitable for time difference measurements provided that they are either of the same frequency, or if the frequency of one waveform is a multiple of the other.

In order to determine the expected accuracy of a time or frequency measurement, the following sources of possible error should be considered:

- a. Main and delayed time-bases. With the TIME/div. potentiometer set to CAL, the time-base may cause a possible error of  $\pm 3\%$  in any reading taken over the middle eight horizontal divisions of the horizontal graticule. If the selected deflection coefficient is either 1 s/div., 0.5 s/div., or 0.2 s/div., then the maximum time-base error is increased to  $\pm 5\%$ .
- b. The 'PULL FOR x5' MAGN switch. Use of this switch adds a further  $\pm 2\%$  to the possible error quoted in sub para. (a)
- c. Read-off error. The maximum absolute read-off error is considered to be 0.05 divisions per read-off (i.e. readings taken between two points on the graticule may involve a total possible read-off error of  $2 \times 0.05 = 0.1$  divisions). When expressed as a percentage, the read-off error is inversely proportional to the number of divisions over which the reading has been taken.
- d. DELAY TIME MULTIPLIER control. When a number of vernier digits has been counted from this control, a total absolute read-off error of 0.010 digits (0.005 digits per read-off) is possible. This error is made inversely proportional to the number of digits counted, when expressed as a percentage.
- d. DELAY TIME MULTIPLIER non-linearity. Non-linearity of this control amounts to  $\pm 0.1\%$ .

### 2. Time measurements using the main time-base

The following procedure can be used to determine the time difference between two points on a waveform:

- Connect the signal to be examined to the  $Y_A$  input socket
- Set the A/OFF/A-B switch to A, and the B/OFF/-B to OFF
- Set the GAIN switch to x1
- Set the AUTO/TRIGG/SINGLE switch to AUTO
- Set the  $Y_A/Y_B/EXT$  switch to  $Y_A$
- Set the HF/LF/DC switch to the appropriate position, depending upon the frequency of the input signal
- Set the X DEFL switch to MAIN TB
- Set the AMPL switch in order to obtain as large a signal as possible.  
Adjust the main time-base triggering controls in order to obtain a stable display
- Set the main time-base TIME/div. potentiometer to its CAL position
- Set the main time-base TIME/div. switch to a position which provides the greatest possible horizontal distance between the measuring points.  
In the interests of accuracy, it is advisable not to use the first and last divisions of the graticule
- Using the X POSITION control, align one of the measuring points with the nearest vertical graticule line

- Use the  $Y_A$  channel POSITION control to align the other measuring point with the horizontal centre-line of the graticule shown in Fig. VIII-3.
- Check that the first measuring point has not strayed during the  $Y_A$  position control operation
- Measure the horizontal distance ( $\leftarrow t \rightarrow$ ) between the two measuring points
- Calculate the time period by multiplying the horizontal distance between the two measuring points, by the deflection coefficient to which the main time-base TIME/div. switch is set. Divide the product by five only if the MAGN switch has been operated.

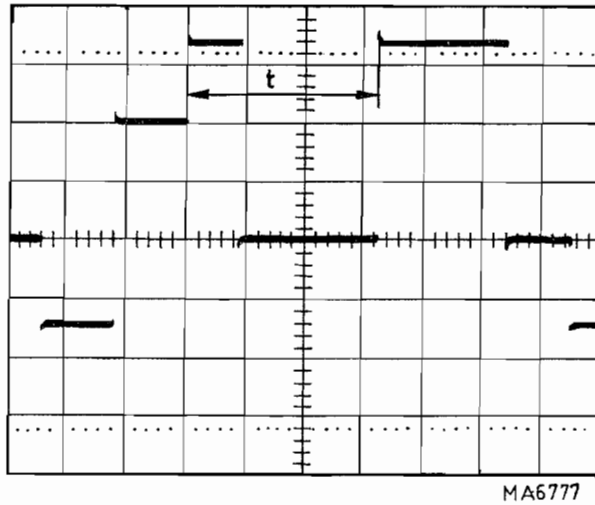

Fig. VIII-3. Main time-base time measurement with one measuring point aligned with a vertical graticule and the other measuring point aligned with the horizontal centre-line

### 3. Time difference measurements between two separate pulses using the main time-base

The time difference between two separately displayed pulses may be evaluated with the aid of the PM 3250 oscilloscope. It should be noted, however, that the oscilloscope can only present a stable display of two separate waveforms if the frequency of one waveform is a multiple of the other.

Waveforms having the same frequency may also be displayed simultaneously. The method used to measure the time difference between the respective edges of two separately display pulses is as follows:

- Connect the two signals to the  $Y_A$  and  $Y_B$  input sockets using probes or coaxial leads with identical time delay properties
- Set the AC/0/DC switches to the position which are best suited to the input signals
- Set the CHOPP/ALT switch to CHOPP for low frequencies, or to ALT for high frequencies
- Set the A/OFF/A-B switch to A, and the B/OFF/-B switch to B. If the signals show opposite polarity, the necessary inversion can be made by transferring the B/OFF/-B switch to the -B position
- Set the  $Y_A/Y_B/EXT$  to the channel ( $Y_A$  or  $Y_B$ ) which carries the signal which leads in time
- Adjust the main time-base triggering controls for a stable display
- Set the TIME/div. potentiometer of the main time-base to its CAL position, before setting the associated TIME/div. switch to the setting which provides the greatest horizontal distance between the measuring points
- Use the POSITION controls of the two channels to position the two traces symmetrically about the centre-line of the graticule
- Using the X POSITION control, shift the display until one of the measuring points passes through a junction formed by a vertical graticule line and the horizontal centre-line shown in Fig. VIII-4.
- Measure the horizontal distance ( $\leftarrow t \rightarrow$ ) between the two measuring points by means of the graduated horizontal centre-line

- Multiply the measured horizontal distance by the deflection coefficient to which the main time-base TIME/div. switch is set.
- Divide this product by five only if the MAGN switch has been operated.

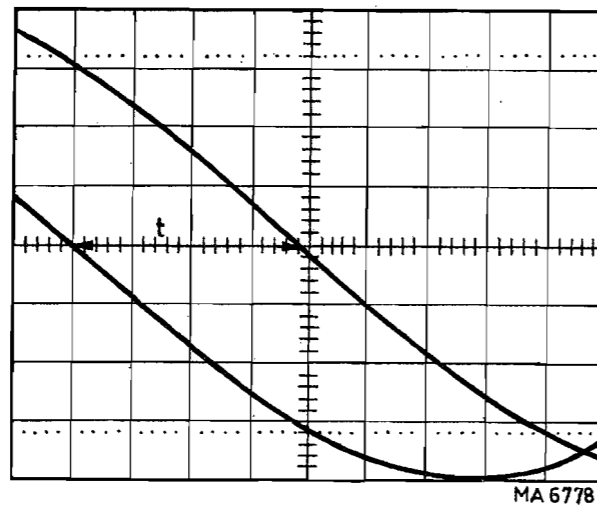

Fig. VIII-4. Separately displayed signals shifted so that one time difference measuring point passes through the junction formed by a vertical graticule line and the horizontal centre-line

#### 4. Time measurements using the delayed time-base

##### a. General information

With the X DEFL switch set to MAIN TB, the DELAY TIME MULTIPLIER can be used in conjunction with the delayed time-base TIME/div. switch, to intensify a given portion of the displayed waveform. An enlarged presentation of this intensified portion is obtained when the X DEFL switch is set to DEL'D TB. This facility is particularly useful for making accurate pulse width measurements. The width of one or more displayed pulses may be accurately evaluated by recording the number of calibrated DELAY TIME MULTIPLIER divisions required to shift the pulse or pulses across a reference graticule. The recorded number of divisions, when multiplied by the main time-base TIME/div. switch setting, provides the pulse width time. This method enables use of the delayed time-base TIME/div. potentiometer so that an exact portion of the waveform can be chosen for enlarged display. Assume that it is required to calculate the width between points P<sub>1</sub> and P<sub>2</sub> shown in Fig. VIII-5. The intensified portion is shown in Fig. VIII-6. and the enlarged display, obtained when the X DEFL switch is set to DEL'D TB, is shown in Fig. VIII-7. Firstly, point P<sub>1</sub> is aligned with the vertical centre-line of the graticule (Fig. VIII-8). The DELAY TIME MULTIPLIER is then used to shift the waveform across the screen until point P<sub>2</sub> is aligned with the vertical centre-line of the graticule (Fig. VIII-9). The recorded number of DELAY TIME MULTIPLIER divisions, when multiplied by the main time-base TIME/div. switch setting, provides the pulse width time. An alternative method involves counting the number of graticule divisions which separate the two measuring points. The delayed time-base TIME/div. switch setting can then be used to evaluate the pulse width. When this method is used, it is imperative that the delayed time-base TIME/div. potentiometer is set to its CAL position throughout the procedure, otherwise the deflection coefficient setting will not be accurate.

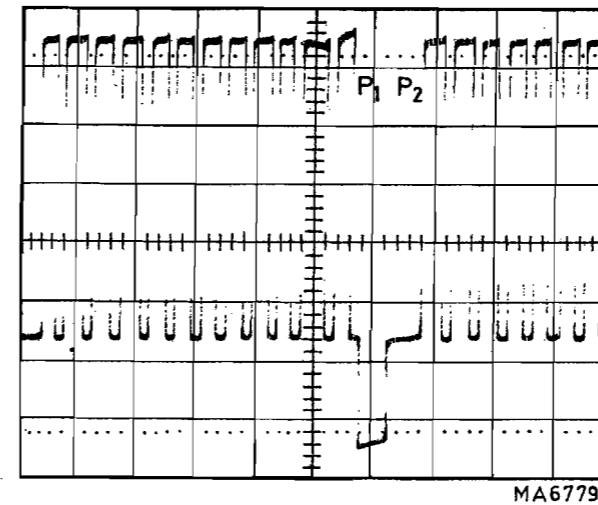

Fig. VIII-5. Basic waveform

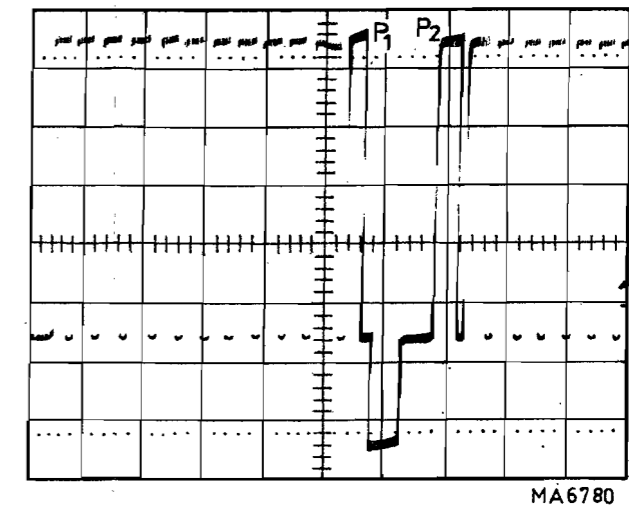

Fig. VIII-6. Intensified portion of basic waveform

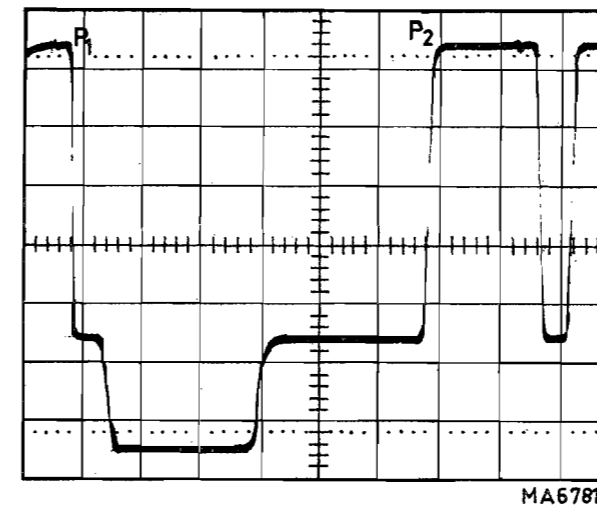

Fig. VIII-7. Enlarged display of the intensified portion obtained by setting the X DEFL switch to DEL'D TB

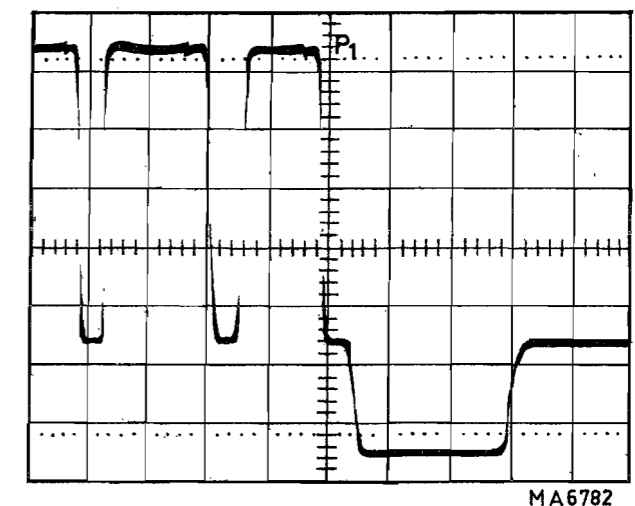

Fig. VIII-8. Point P<sub>1</sub> aligned with the vertical centre-line of the graticule (DELAY TIME MULTIPLIER control reads 5.17)

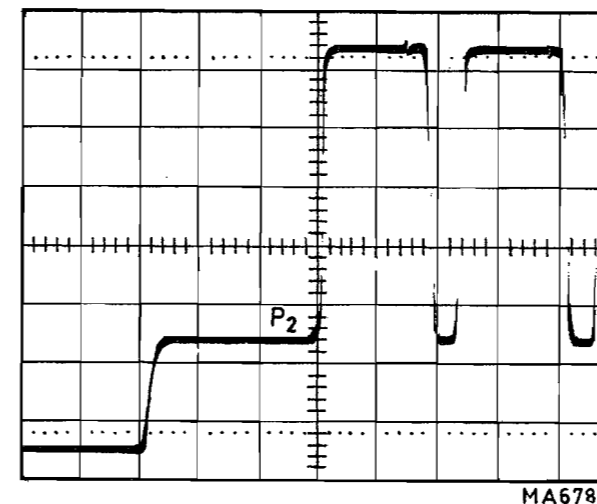

Fig. VIII-9. Waveform shifted across the screen until point P<sub>2</sub> is aligned with the vertical centre-line of the graticule (DELAY TIME MULTIPLIER control reads 6.32)

### b. Using the DELAY TIME MULTIPLIER

To measure a pulse width using the DELAY TIME MULTIPLIER, proceed as follows:

- Connect the signal to the Y<sub>A</sub> input socket
  - Set the A/OFF/A-B switch to A, and the B/OFF/-B switch to OFF
  - Set the AUTO/TRIGG/SINGLE switch to AUTO
  - Position the display symmetrically about the centre-line of the graticule
  - Set the AMPL switch of channel A to the position which provides the maximum possible display within the viewing area
  - Set the main time-base TIME/div. potentiometer to its CAL position
  - Adjust the triggering controls to obtain a stable display
  - Set the AFTER DELAY TIME switch to the STARTS position
  - Using the DELAY TIME MULTIPLIER control in conjunction with the delayed time-base TIME/div. switch and potentiometer, intensify the portion of the waveform which is to be examined
  - Transfer the X DEFL switch from the MAIN TB to the DEL'D TB position. An enlarged display of the intensified portion of the waveform will be presented
  - Use the DELAY TIME MULTIPLIER control to align the left hand measuring point with the vertical centre-line of the graticule.
  - Note the reading of the DELAY TIME MULTIPLIER control
  - Rotate the DELAY TIME MULTIPLIER control until the right hand measuring point is aligned with the vertical centre-line. Note the new reading
  - Subtract the smaller DELAY TIME MULTIPLIER reading from the larger.
- Multiply the resulting difference by the main time-base TIME/div. switch setting, in order to obtain the pulse width time. The answer must be divided by five only if the MAGN switch has been used.

### c. Using the graticule

To measure the pulse width by means of the graticule (instead of using the DELAY TIME MULTIPLIER) proceed as follows:

- Set up the signal in accordance with the first ten steps of the above procedure, but keep the TIME/div. potentiometers of both the main and delayed time-bases in their CAL positions
- Use the X POSITION control to shift the left hand measuring point so that it is aligned with a convenient point on the horizontal centre-line of the graticule
- Count the number of horizontal divisions which separate the two measuring points. Multiply the number of divisions by the deflection coefficient to which the delayed time-base TIME/div. switch is set. Multiply this answer by five only if the MAGN switch has been operated.

## 5. Rise time measurements

### a. General information

The rise time of a pulse is defined as the period of time taken for the leading edge of the pulse to rise from 10 % to 90 % of its total amplitude, as shown in Fig. VIII-10.

Reference to the oscilloscope graticule will show two dotted lines, which are the 10 % to 90 % points of the vertical scale. If, therefore, a leading edge is displayed in such a way that its peak is aligned with the top most horizontal graticule line and its lower level aligned with the bottom horizontal graticule line, then the dotted lines indicate the 10 % and 90 % values of the edge. In many cases, it is required to measure a rise time which is of the same order as that of the oscilloscope. In such cases, subject to the conditions discussed below, the actual rise time of the pulse can be calculated with the aid of equations having the following general form:

$$T_{ra} = \sqrt{T_{fm}^2 - T_{fo}^2}$$

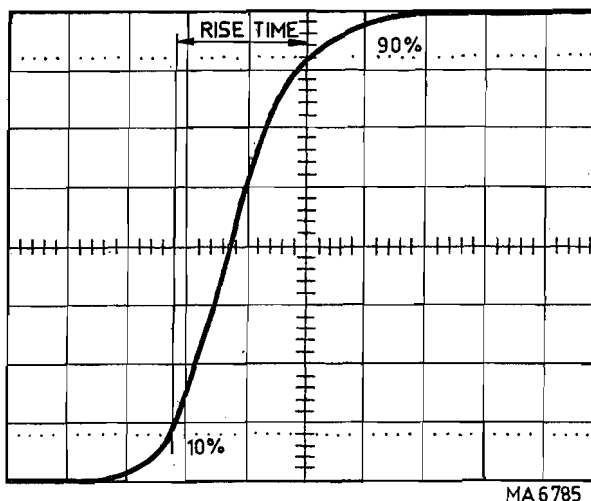

Fig. VIII-10. Definition of rise time

where  $T_{ra}$  is the actual rise time,  $T_{rm}$  the measured rise time, and  $T_{ro}$  the rise time of the oscilloscope (nominally 7 ns at x1 gain and 70 ns at x10 gain). Maximum rise time measurement accuracy will be obtained by observing the following conditions:

Rise time measurements made with the GAIN switch at x1

No correction formula need be applied if a rise time (measured with the aid of the dotted 10% and 90% reference lines) is greater than three times the nominal rise time of the instrument, i.e. 21 ns. This is due to the fact that the measured rise time is only expected to be 5% greater than the actual rise time of the signal.

In those cases where the measured rise time is equal or greater than 10 ns, but is less than 21 ns, then the influence of the oscilloscope rise time is significant. The following formula must therefore be used in order to apply correction to the measured rise time:

$$T_{ra} = \sqrt{T_{rm}^2 - T_{ro}^2}$$

If an accurate result is required from a measured rise time of less than 10 ns, then the rise time of the oscilloscope must be measured.

This can be done by applying the following procedure:

- Set up a display which is suitable for making a rise time measurement, then temporarily disconnect the input signal
- Connect a fast pulse generator to the input socket, taking care not to disturb any settings of the oscilloscope

Note that the degree of accuracy obtained from this procedure is largely dependent upon the rise time of the fast pulse generator. The rise time of the fast pulse generator must, therefore, be extremely small when compared with 7 ns (i.e. the rise time of the oscilloscope)

- Set the output voltage of the fast pulse generator to the exact amplitude of the input signal display. For example, assuming that the rise time of the signal examination is to be measured over the full eight divisions of the graticule, the output voltage of the fast pulse generator must be set to give an eight division display. Measure the rise time of the displayed pulse, which will be almost the rise time of the oscilloscope in the particular setting. Record this rise time.
- Disconnect the fast pulse generator and reconnect the input signal
- Measure the rise time of the signal
- Calculate the actual rise time of the signal using the formula:

$T_{ra} = \sqrt{T_{rm}^2 - T_{rop}^2}$ , where  $T_{rop}$  is the actual rise time of the particular oscilloscope, as measured with the fast pulse generator.

If a rise time of the same order as that of the oscilloscope (i.e. actual rise times of 10 ns or less) is measured without the application of the correction procedure detailed above, the total measuring error can be reduced by using only the 5.6 vertical divisions about the horizontal centre-line. This precludes the use of the dotted 10 % and 90 % reference lines, so that the 10 % and 90 % levels must be plotted by the operator. In addition to this, the TIME/div. potentiometer must be set to its CAL position.

Rise time measurements made with the GAIN switch set to x10 .

Rise time measurements are rarely made with the oscilloscope operating in the x10 mode. However, if a circumstance arises in which it is desirable to set the GAIN switch to its x10 position, the conditions specified above for x1 GAIN settings can be followed. It must, although, be remembered that the oscilloscope rise time will be 70 ns (i.e. ten times the rise time of the oscilloscope operating in the x1 mode). This much larger rise time involves a greater quantitative deviation from the nominal 70 ns rise time. A rise time measured with the oscilloscope in the x10 gain mode will therefore be subject to a greater possibility of error, as shown by the following theoretical explanation:

Influence of error in x1 gain setting

$$T_{rm}^2 = T_{ra}^2 + T_{rop}^2 = T_{ra}^2 + T_{ro}^2 + \left(\frac{x}{100}\right)^2 T_{ro}^2$$

Where  $T_{rop}$  is the rise time of the particular oscilloscope, and x is the positive or negative percentage deviation of  $T_{rop}^2$  from  $T_{ro}^2$  ( $T_{ro}$  being the nominal rise time of the oscilloscope, i.e. 7 ns)

$$T_{rm}^2 = T_{rac}^2 + T_{ro}^2 \text{ ----- 1}$$

$$T_{rm}^2 = T_{raa}^2 + T_{rop}^2 \text{ ----- 2}$$

Where  $T_{rac}$  is the calculated actual rise time, and  $T_{raa}$  is the accurate rise time of the signal.

Equating 1 and 2:

$$T_{rac}^2 + T_{ro}^2 = T_{raa}^2 + T_{rop}^2$$

$$\text{Since } T_{rop}^2 = T_{ro}^2 \left(1 + \frac{x}{100}\right), T_{raa}^2 = T_{rac}^2 - \frac{x T_{ro}^2}{100} \text{ ----- A}$$

Influence in x10 gain setting

$$\begin{aligned} T_{rm\ x10}^2 &= T_{rac}^2 + (10 T_{ro\ x10})^2 \\ &= T_{rac}^2 + 100 T_{ro\ x10}^2 \text{ ----- 3} \end{aligned}$$

Also,

$$T_{rm\ x10}^2 = T_{raa}^2 + 100 T_{ro\ x10}^2 \left(1 + \frac{x}{100}\right) \text{ ----- 4}$$

Equating 3 and 4,

$$T_{raa}^2 = T_{rac}^2 - x T_{ro}^2 \text{ ----- B}$$

Comparing equations A and B, it can be seen that x has an effect which is 100 times larger when the oscilloscope is operating in the x10 mode.

**b. Rise time measurements using the main time-base**

The following method can be used to determine the rise time of a waveform in which all pulses are identical, both in shape and in period. If the rise time of particular pulse in an irregular waveform is to be measured, then use the delayed time-base method which is detailed in para c.

- Connect the signal to the Y<sub>A</sub> input socket
- Set the A/OFF/A-B switch to A, and the B/OFF/-B switch to OFF
- Set the AUTO/TRIGG/SINGLE switch to AUTO
- Set the LF/HF/DC switch to the appropriate position, depending upon the frequency of the signal
- Set the main time-base TIME/div. switch to its CAL position
- Adjust the main time-base trigger controls for a stable display
- Set the main-time base TIME/div. switch to a position which enables one complete edge of the pulse shape to be displayed

- Using the Y<sub>A</sub> POSITION control in conjunction with the AMPL switch and AMPL potentiometer, obtain a condition in which the pulse shape begins at the bottom horizontal graticule line and ends at the top graticule line (i.e. the vertical deflection rises through exactly eight horizontal divisions). Make any necessary adjustment to the ILLUM and INTENS controls in order to make the display clear, shown in Fig. VIII-11.
- Further expand the trace in the horizontal plane, by means of the main time-base TIME/div. switch. Stabilize the display using the LEVEL potentiometer
- Pull the MAGN switch when its effect will reduce read-off error
- Use the X POSITION control to gradually shift the display until the edge of the pulse shape coincides with a junction of the dotted 10 % line and a vertical graticule. Check that, with the trace so positioned, the intersection of the trace and the dotted 90 % line is still visible. The vertical graticule line which forms the junction with the dotted 10 % line and the trace edge is now the time reference point, so that no readjustment of the X POSITION control must be made
- Check, by means of the main time-base TIME/div. switch, that the trace still has an amplitude of exactly eight divisions before measuring the horizontal distance between the points at which the edge intersects the dotted 10 % and 90 % reference lines

Calculate the measured rise time by multiplying the horizontal distance by the deflection coefficient to which the TIME/div. switch is set.

Divide this product by five only if it has been necessary to use the MAGN switch.

If the measured rise time is of the same order as that of the oscilloscope, then use the formula quoted at the beginning of this paragraph to evaluate the actual rise time of the signal, which may be considerably less than the measured rise time (see introductory paragraphs).

For example, with a TIME/div. setting of 0.05 μs, a GAIN switch setting of x10, and a measured horizontal separation of 3.4 divisions, the measured time rise will be:

$$T_{rm} = 3.4 \text{ div.} \times 50 \text{ ns} = 170 \text{ ns}$$

Since the GAIN switch is set to x10, the rise time of the oscilloscope is 70 ns which is significant when compared with the measured rise time.

The actual rise time must therefore be calculated, as follows:

$$\begin{aligned} T_{ra} &= \sqrt{T_{rm}^2 - T_{ro}^2} \\ &= \sqrt{170^2 - 70^2} &&= 155 \text{ ns} \end{aligned}$$

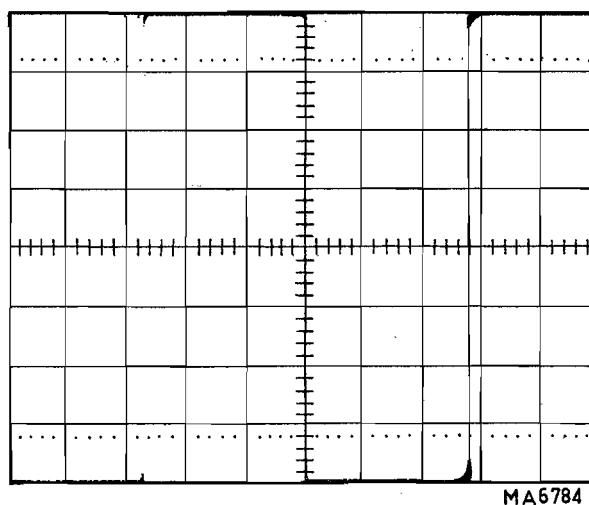

Fig. VIII-11. Square wave pulse with one edge intensified for the purpose of rise time measurement

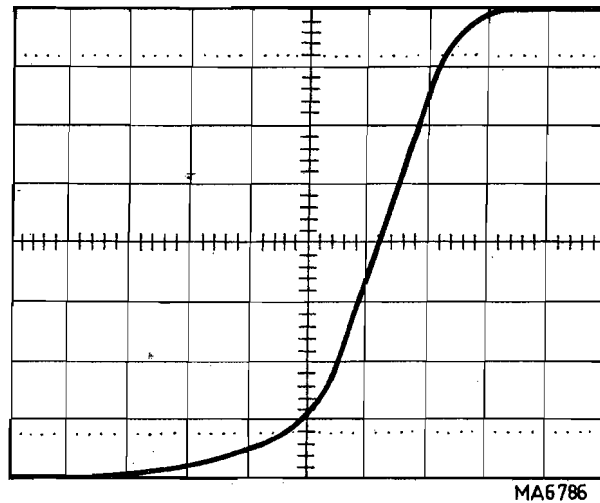

Fig. VIII-12. Enlarged display of the intensified edge which is obtained when the X DEFL switch is set to DEL'D TB

### c. Rise time measurements using the delayed time-base

The following procedure is used when it is required to identify a particular pulse from a series, in order to measure its rise time or to examine it in detail.

- Connect the signal to the  $Y_A$  input socket
- Set the A/OFF/-B switch to A, and the B/OFF/-B switch to OFF
- Set the AUTO/TRIGG/SINGLE switch to AUTO
- Set the delayed time-base TIME/div. potentiometer to its CAL position
- Using the main time-base TIME/div. switch and potentiometer, display the required train of pulses on the screen
- Use the  $Y_A$  POSITION control in conjunction with the AMPL switch and AMPL potentiometer of channel A, to adjust the display until it is large enough for a detailed examination
- Set the TIME/div. switch of the delayed time-base to the smallest possible deflection coefficient which may be used to obtain an intensified portion of the waveform of the same width as the pulse under examination
- Use the DELAY TIME MULTIPLIER to shift the intensification to the pulse which is to be examined
- Set the MAIN TB/DEL'D TB/EXTERN switch to DEL'D TB. The selected pulse will now be displayed
- Use the  $Y_A$  POSITION control in conjunction with the AMPL switch and AMPL potentiometer, to obtain a condition in which the edge of the displayed pulse begins on the bottom horizontal graticule line and ends at the top graticule line (i.e. the vertical deflection rises through exactly eight horizontal graticule divisions) See Fig. VIII-12.
- Further expand the display in a horizontal plane by means of the delayed time-base TIME/div. switch. Stabilize the display using the main time-base LEVEL control. Stabilization is also possible using the main time-base triggering controls when the AFTER DELAY TIME switch is transferred from STARTS to TRIGG
- Use the X POSITION potentiometer to gradually shift the display until the edge of the pulse coincides with a junction formed by the dotted 10 % line and a vertical graticule line. The edge of the pulse must still intersect the dotted 90 % line. Since the vertical line forming the junction with the dotted 10 % line is now the reference point, no readjustment must be made to the X POSITION control
- Check, by means of the delayed time-base TIME/div. switch, that the display has an amplitude of exactly eight divisions before measuring the horizontal distance between the time reference point and the point at which the trace cuts the dotted 90 % line
- Calculate the rise time as detailed in the previous paragraph



## 6. Phase difference measurements

### a. General information

The phase difference between two separately displayed sinusoidal signals may be evaluated with the aid of the PM 3250 oscilloscope.

The following methods may be applied to signals having a frequency of up to 50 MHz, provided that the GAIN switch is set to x1. If the GAIN switch is set to x10, then an accurate result can only be obtained from waveforms of up to 5 MHz in frequency.

The main time-base is used for fairly large phase difference measurements, whereas the delayed time-base is best suited to the measurement of small phase differences. In order to assess the total possible error in a phase difference measurement, reference should be made to the introductory paragraphs which explain the various sources of possible error.

### b. Phase difference measurements using the main time-base

This method is used to measure large phase differences. If, therefore, a reasonably large separation between the displayed pulses cannot be obtained, the delayed time-base should be used, as detailed in sub para c. If the phase difference between the two displayed pulses appears to be less than  $80^\circ$ , use the MAGN switch to enlarge the display. Proceed as follows:

- Connect the two signals to the  $Y_A$  and  $Y_B$  input sockets using probes or coaxial cables with identical time delay properties
- Set the AC/0/DC switches to the positions which are best suited to the input signals
- Set the CHOPP/ALT switch to CHOPP for low frequencies, or to ALT for high frequencies

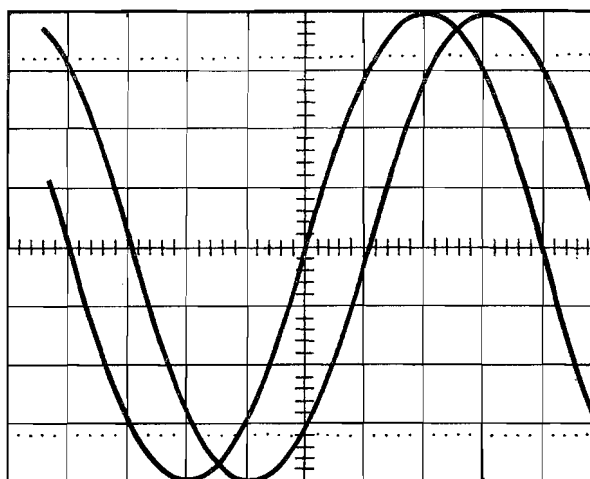

Fig. VIII-13. Main time-base phase difference measurement with leading waveform displayed over exactly eight divisions

- Set the A/OFF/A-B switch to A, and the B/OFF/-B switch to B
- Set the  $Y_A/Y_B/EXT$  switch to the channel ( $Y_A$  or  $Y_B$ ) carrying the signal which leads in time
- Adjust the main time-base LEVEL control so that the waveform commences at a suitable point on the graticule
- A  $180^\circ$  phase inversion may be applied to channel B by setting the B/OFF/-B switch to -B. This inversion must be taken into account when the actual phase difference is calculated
- Using the AMPL switches and their associated potentiometers, adjust both waveforms until they are equal in amplitude. The waveforms should be as large as possible (preferably a full eight vertical divisions) See Fig. VIII-13.
- Correct any instability by using the main time-base triggering controls

- If necessary, use the POSITION controls in order to dispose both waveforms symmetrically about the centre-line
- Set the TIME/div. switch and TIME/div. potentiometer of the channel which carries the leading waveform, in order to display the leading waveform over exactly eight horizontal divisions. In this condition, each division represents  $360^{\circ}/8 = 45^{\circ}$ . If the MAGN switch has been operated, each division will represent only  $9^{\circ}$

Note that the MAGN switch should only be used if the displayed phase difference is less than two divisions. In such cases where a phase difference is seen to be less than two divisions, the results obtained from the main time-base method will only be acceptable if the frequency of the input signal is less than 5 MHz. For higher frequencies, the delayed time-base method should be used.

- Measure the horizontal distance between the waveforms, and multiply the result by  $45^{\circ}$  (or by  $9^{\circ}$  if the MAGN switch has been operated). The answer will be the phase difference

### c. Phase difference measurements using the delayed time-base

This method is used in cases where the phase difference is small.

Set up the display in accordance with the first ten steps of the previous paragraph, then proceed as follows:

- Set the TIME/div. potentiometers of both channels to CAL
- Temporarily switch off the channel which carries the lagging phase and use the appropriate TIME/div. switch to display the leading signal over the largest possible distance, without use of the first and the last division
- Measure the horizontal distance between the zero and  $360^{\circ}$  points of the leading signal. Determine the period of the leading signal by multiplying the horizontal distance by the deflection coefficient setting of the associated TIME/div. switch
- Set the AFTER DELAY TIME switch to STARTS
- Set the TIME/div. switch of the delayed time-base to a position which produces the smallest possible length of display intensification, shown in Fig. VIII-14. A small readjustment of the INTENS control may prove necessary
- Adjust the DELAY TIME MULTIPLIER, in conjunction with the TIME/div. switch of the delayed time-base, in order to shift the intensified portion to the point at which the two pulses cross the centre-line of the graticule
- Set the MAIN TB/DEL'D TB/EXT switch to DEL'D TB. An enlarged display of the intensified portion will now be presented
- Obtain any possible enlargement of the new display using the delayed time-base TIME/div. switch. It may now be necessary to make a small adjustment to the FOCUS control
- Shift the display by means of the POSITION control, until one of the measuring points is aligned with its nearest vertical graticule line shown in Fig. VIII-15.
- Measure the horizontal distance between the two measuring points which represents the phase difference. Multiply this measured distance by the deflection coefficient setting of the delayed time-base. This result is the time duration between the two edges
- Insert the values obtained into the following formula, where T is the period of one complete cycle, and  $\Delta T$  is the time duration between pulses:

$$\text{Phase difference} = \frac{\Delta T}{T} \times 360^{\circ}$$

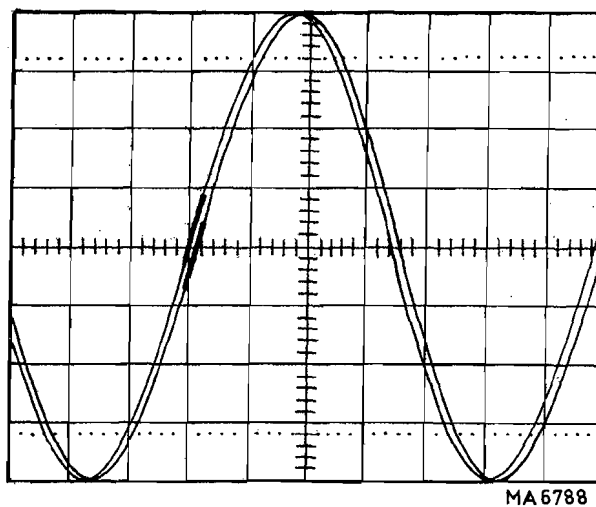

*Fig. VIII-14. Phase difference display with the intensified portion located at a point where the two pulses cross the centre-line*

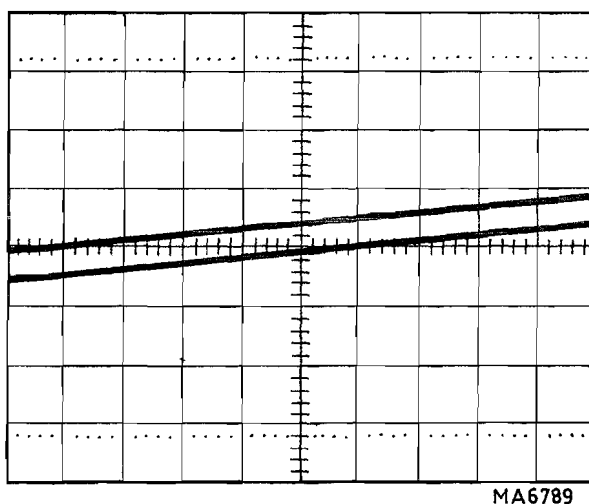

*Fig. VIII-15. Enlarged portion of the display with one measuring point shifted to its nearest vertical graticule line*

## D. X-Y MEASUREMENTS

### 1. Introduction

When the X DEFL switch is set to EXTERN via YB, channel A input provides the Y deflection and channel B input provides the X deflection. The PM 3250 oscilloscope can therefore be used to perform X-Y measurements, so that phase difference and frequency measurements can be performed.

### 2. Phase difference measurements

When the oscilloscope is operating in the X-Y mode, the input of two sinusoids having identical frequency will result in the display of a line. If there is a phase difference between the two signals, an elliptical display will be obtained. The dimensions of this display can be used to evaluate the phase difference. Proceed as follows:

- Connect the two signals to the  $Y_A$  and  $Y_B$  input sockets
- Use the AMPL switches and potentiometers to produce as large a display as possible within the viewing area
- Shift the displayed figure until its left hand edge just touches a vertical graticule line. Call the point at which the waveform touches the vertical graticule line point A
- Determine the farthest point to which the right hand edge of the figure extends. Call this point B
- Measure the vertical distance between points A and B, also measure the total vertical distance of the figure
- Evaluate the sine of the phase difference angle by inserting the two measured quantities into the following formula:  

$$\text{Sine of phase difference angle} = \frac{\text{Vertical distance between A and B}}{\text{Total vertical distance of figure}}$$

Reference to trigonometric tables will enable the phase angle to be found.

### 3. Frequency measurements

Use of a high accuracy sine wave generator in conjunction with the PM 3250 oscilloscope enables unknown frequencies to be measured.

This technique involves the display of Lissajous figures using the generator as a variable reference source. With the oscilloscope operating in the X-Y mode, the unknown frequency is applied to one input channel and the sine wave generator is connected to the other channel. The sine wave generator can then be adjusted to a frequency at which a stable display of a Lissajous figure is obtained. The reading of the sine wave generator and the shape of the figure can then be used to evaluate the unknown frequency.

## E. DIFFERENTIAL MEASUREMENTS

### 1. Introduction

The difference between two separately displayed signals can be presented by setting the A/OFF/A-B switch to A-B. In this circumstance, the signal connected to channel  $Y_B$  is displayed together with the waveform which represents the difference between the two inputs.

If, therefore, the two displayed signals are in common mode (i.e. the signals are constantly equal in potential) then the difference signal will be zero and the resulting display will be a horizontal linear trace.

When a very small a.c. signal is superimposed upon one of two common mode signals, the common mode component of the waveform may be rejected by setting the A/OFF/A-B switch to A-B.

### 2. Differential measurements

Proceed as follows in order to make a differential measurement:

- Set the AC/0/DC switches to DC
- Connect the two signals to the  $Y_A$  and  $Y_B$  sockets using probes or cables with identical time delay properties
- Set the AUTO/TRIGG/SINGLE switch to AUTO
- Set both AMPL potentiometers to the CAL position
- Set the two AMPL switches to settings which are equal and which produce the largest possible display within the viewing area
- Set the A/OFF/A-B switch to A-B. The difference in amplitude will now be displayed. This display may be enlarged by stepping both AMPL switches simultaneously, to more sensitive positions:  
 The channel B display can be removed from the screen by setting the B/OFF/-B switch to OFF.  
 Alternatively, the channel B display may be inverted by setting the switch to -B.

In some cases, the common mode rejection may be improved by applying a slight adjustment to one of the AMPL potentiometers

### 3. Common mode rejection factor

Since common mode rejection is partially dependent upon the amplitude ratio of the two signals under examination, the common mode component of a signal may not always be totally rejected.

It is, therefore, necessary to express the common mode rejection factor of a differential oscilloscope. This factor is evaluated by dividing the amplitude of two equal common mode input signals by the amplitude shown in the display which they produce, as shown in Fig. VIII-16. Note that a considerable increase in the AMPL setting may be necessary in order to measure the amplitude of the display

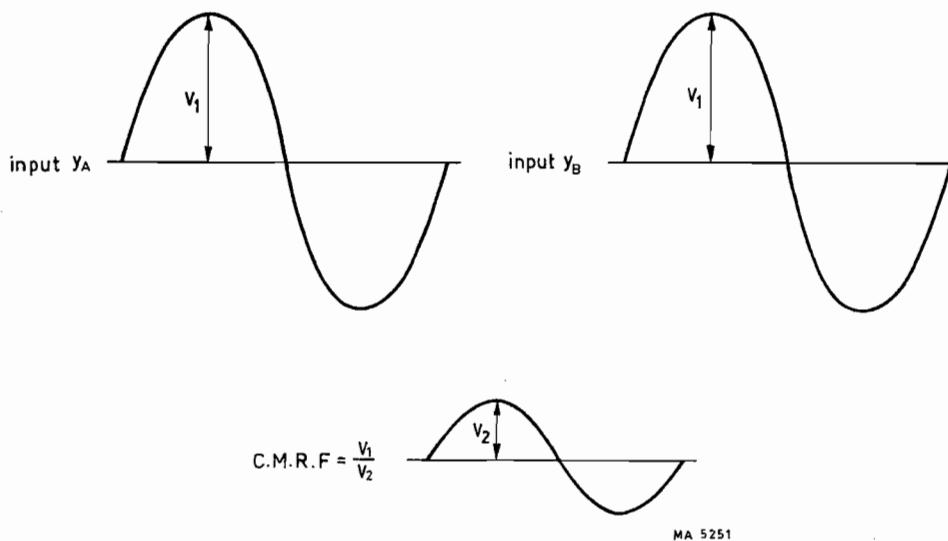

Fig. VIII-16. Determining the common mode rejection factor

## F. OSCILLOSCOPE OUTPUT SIGNAL APPLICATIONS

A positive square wave gating pulse output at an amplitude of +2 V is available from DEL'D + GATE socket, whenever the delayed time-base is in operation. This output has the same frequency as the delayed time-base circuit, and the gating pulse width is set by the TIME/div. switch of the delayed time-base.

The DEL'D + GATE output may be used to trigger an external circuit at any predetermined instant after the commencement of the main time-base sweep. The amount of delay is chosen by means of the DELAY TIME MULTIPLIER and main time-base TIME/div. controls.

The gating pulse is used as follows:

- Connect the input signal to the  $Y_A$  channel and set the main time-base controls to obtain a stable display
- Set both TIME/div. potentiometers to the CAL position
- Set the AFTER DELAY TIME switch to STARTS
- Use the DELAY TIME MULTIPLIER to set the delay time which will be the product of the main time-base TIME/div. switch setting and the DELAY TIME MULTIPLIER reading
- Connect the gating pulse output to the external circuit. Triggering will occur at the beginning of the intensified portion provided that the circuit triggers on the positive-going edge of the gating pulse, or at the end of the gating pulse if the circuit triggers on the negative-going edge.

## G. PHOTOGRAPHIC SCREEN TRACES

Displays may be photographed by means of the camera assembly PM 9380. Refer to the PM 9380 manual for details.

Reference

Item nr Chapter Checking and Adjusting

Item	Page nr.	Item	Page nr.	Item	Page nr.
C108	37	R122	36	R906	43
C112	42	R123	36	R914	43
C123	42	R141	42	R919	43
C128	42	R143	36	R933	43
C129	42	R145	36	R957	44
C130	42	R191	41	R1036	45
C308	37	R322	36	R1049	45
C312	41	R323	36	R1052	45
C323	41	R341	41	R1090	47
C329	42	R343	38	R1094	47
C330	42	R345	36	R1109	47
C404	41	R391	41	R1122	48
C405	42	R417	39	R1123	48
C408	41	R450	39	R1124	48
C410	41	R461	41	R1159	48
C417	4	R462	41	R1160	48
C418	41	R463	39	R1166	48
C423	41	R468	41	R1208	33
C734	47	R475	39	R1242	33
C937	45	R495	39	R1256	48
C1176	48	R505	43	R1263	48
C1178	48	R525	43	R1308	34
C1306	34	R605	40	R1321	34
C1307	34	R631	40	R1325	34
C1420	38	R632	40	R1327	34
C1421	38	R633	40	R1328	34
C1445	38	R634	40	R1337	34
C1447	38	R638	40	R1339	35
C1601	42	R642	40	R1341	34
C1604	42	R701	44	R1343	35
C1608	42	R703	44	R1344	35
C1609	42	R714	44	R1346	35
		R717	44	R1426	38
		R733	44	R1459	38
		R772	45	R1602	42
		R807	46	R1607	42
		R819	46	R1615	39
		R824	46	R1623	39
		R901	43		

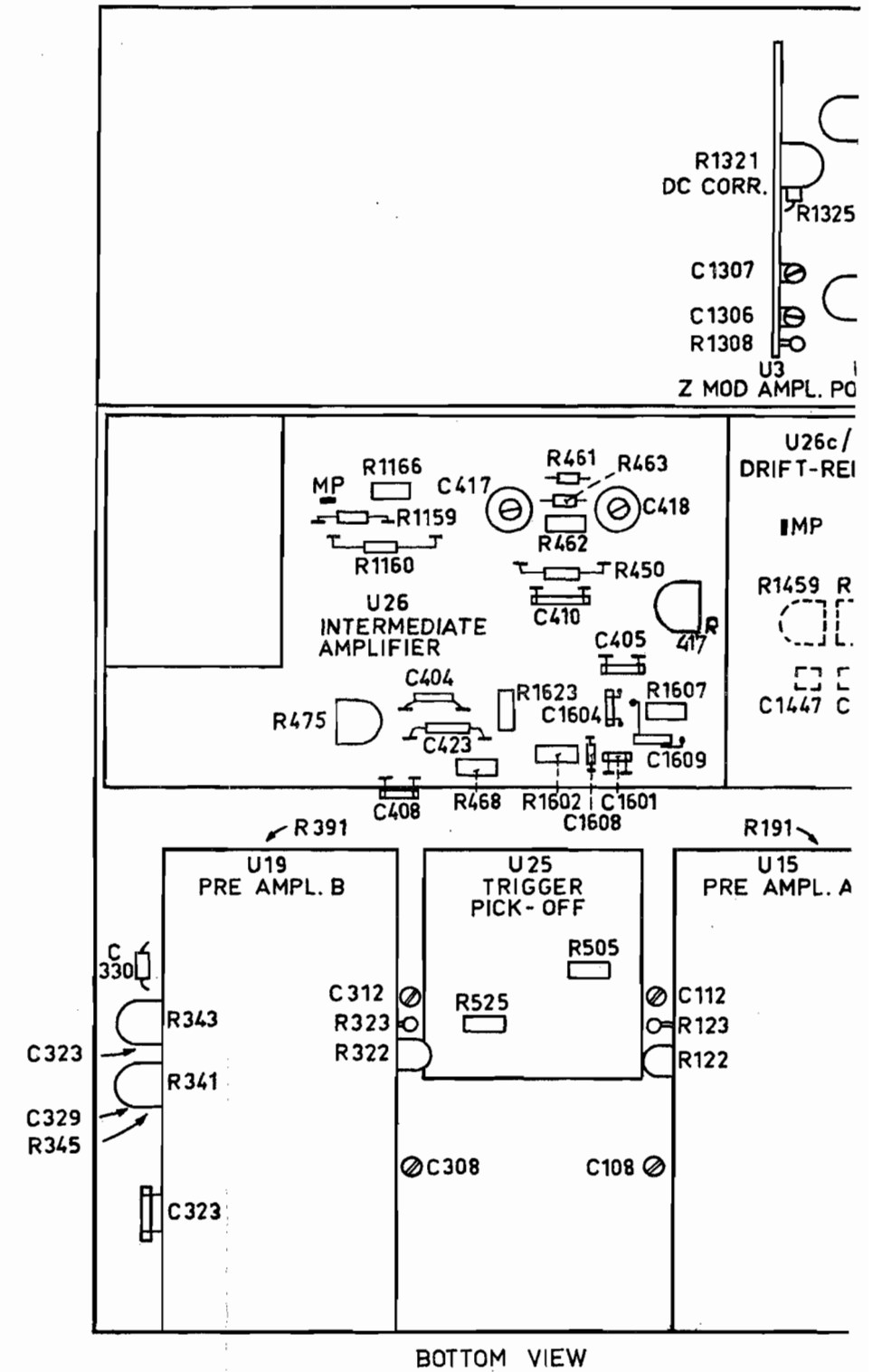

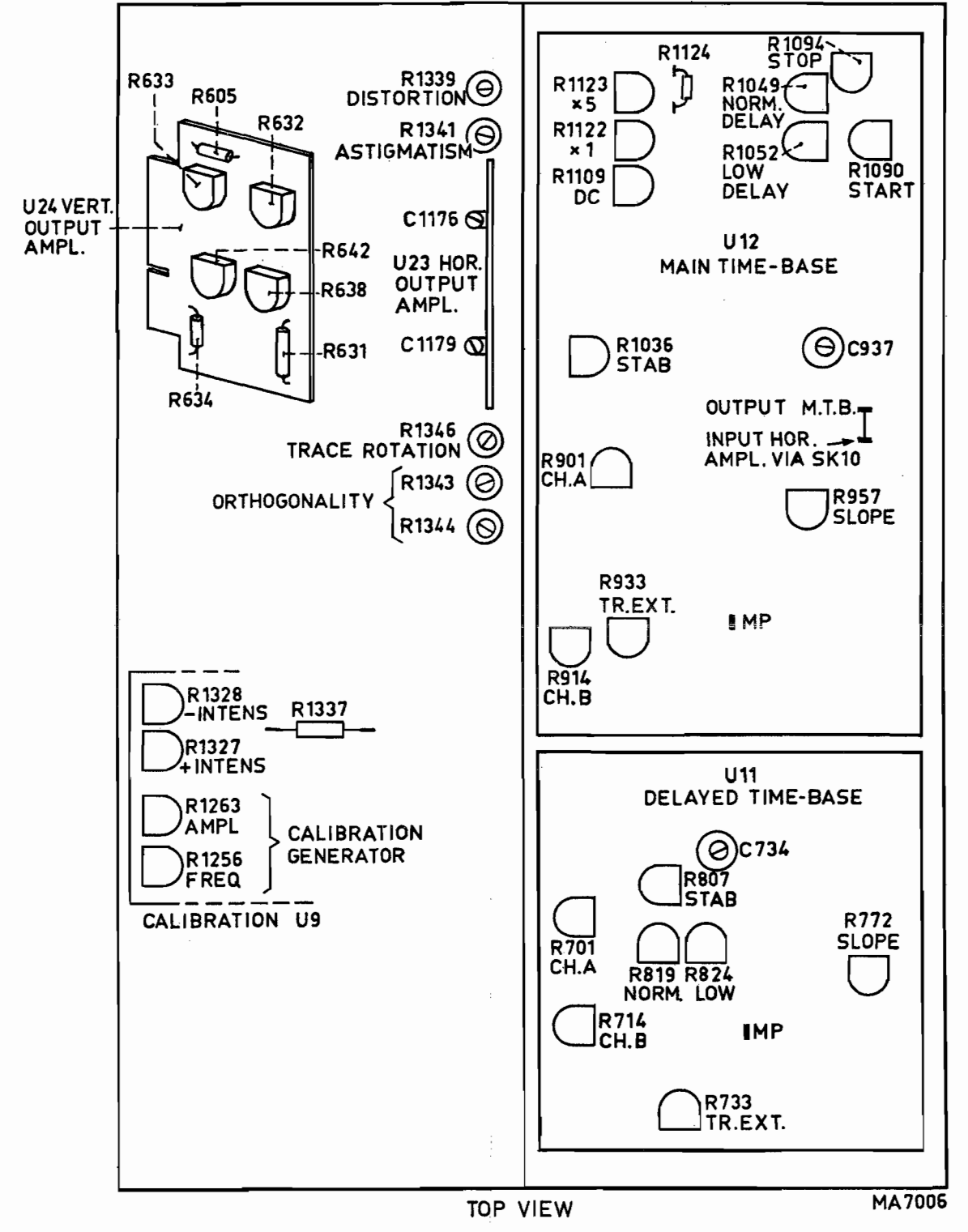
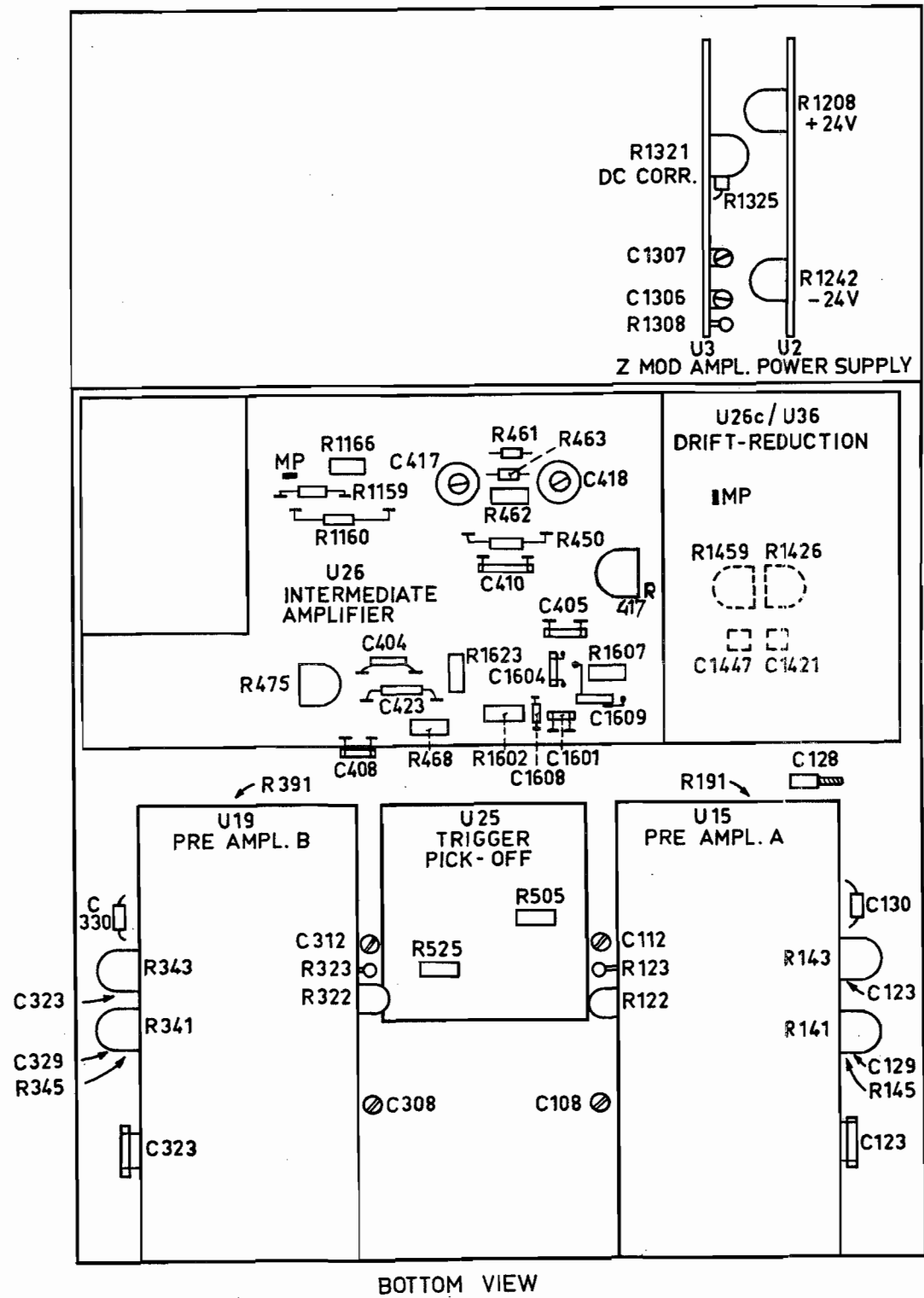

MA7006

Fig. XI-8. Location various adjustment points

## XII. Information for assistance in fault finding

### A. VOLTAGE LEVELS

The d.c. levels on the most important points of the circuits have been indicated on the circuit diagrams. These values may slightly differ per instrument.

The measurements have been carried out under the following conditions:

- Switch "AUTO/TRIGG/SINGLE" in position "AUTO".
- Switch "X DEFL" in position "MAIN TB".
- Switches "AC-0-DC" in position "0".
- Switch "GAIN" in position "x1".
- Potentiometers "Y POSITION" in the centre position.
- Switch "TIME/div" of the main time base in position "1 ms/div".
- For measurements in channel A; switch "B/OFF/-B" in position "OFF" and switch "A/OFF/A-B" in position "A".
- For measurements in channel B; switch "B/OFF/-B" in position "B" and switch "A/OFF/A-B" in position "OFF".

### B. WAVEFORMS

In some circuit diagrams voltage waveforms are shown. The various switch positions are given in these diagrams.

### C. REPAIR HINTS

#### 1. Fault: there is only trace A visible

- Check that the d.c. level on the output of the pre-amplifier A (thus on the cursor of R14) is 0 V. If not, change the connections between the pre-amplifiers and the drift reduction circuits. (Thus connect R127 to R1434, R327 to R1401, R134 to R1467, R334 to R1433).
- If there is now only trace B visible, then the drift reduction circuit of channel A is defective.
- If there is now only trace A visible, then the pre-amplifier of channel A is defective.

#### 2. Fault: there is only trace B visible

- Check the pre-amplifier and the drift reduction circuit of channel B according to point B.1.

#### 3. Fault: the pre-amplifier A is defective

- Remove the connection between R127 and R1401 and the connection between the cursor of R11 and C1404.
- Connect the cursor of R11 to R127.
- Check that the d.c. levels on the different points of pre-amplifier A have the values indicated on the circuit diagram.

#### 4. Fault: the pre-amplifier B is defective

- Remove the connection between R327 and R1434 and the connection between the cursor of R12 and C1431.
- Connect the cursor of R12 to R327.
- Check that the d.c. levels on the different points of pre-amplifier B have the values indicated on the circuit diagram.



Item	Code number	Description
29	5322 528 20165	Flexible shaft coupling
30	5322 255 10007	Lamp holder (LA4, LA5)
31	5322 255 20022	Lamp holder (LA1, LA2)
	5322 462 44023	Insulation cover of lamp holders (LA1, LA2)
32	5322 320 24001	High tension cable complete
33	5322 219 80158	Delay line (L603) complete
34	5322 462 30117	Guide part for print panels
35	5322 255 40054	Transistor cooling radiator (TO-5)
36	5322 255 40089	Transistor socket (TO-18) with four contacts *
37	5322 255 40015	Transistor socket (TO-5)
38	5322 255 70159	C.r.t. socket
39	5322 267 60023	P.c. connector with double row soldering lugs
40	5322 267 50122	P.c. connector with one row side soldering lugs
41	5322 267 60034	P.c. connector with double row soldering lugs
<b>Service tools</b>		
-	5322 395 50104	Trimming rod for input attenuator capacitors
-	5322 263 70035	Extension p.c. board

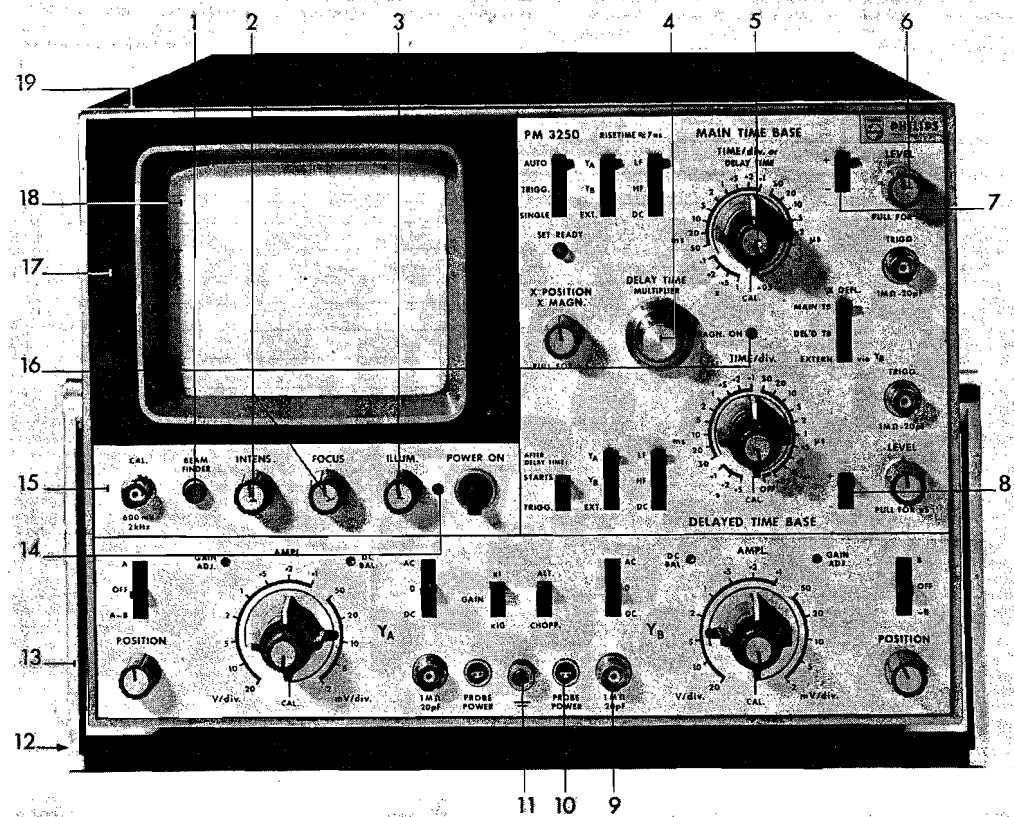

Fig. XIII-1. Front side

\* For replacement of a socket with three contacts, one contact of the replacement socket must be removed.

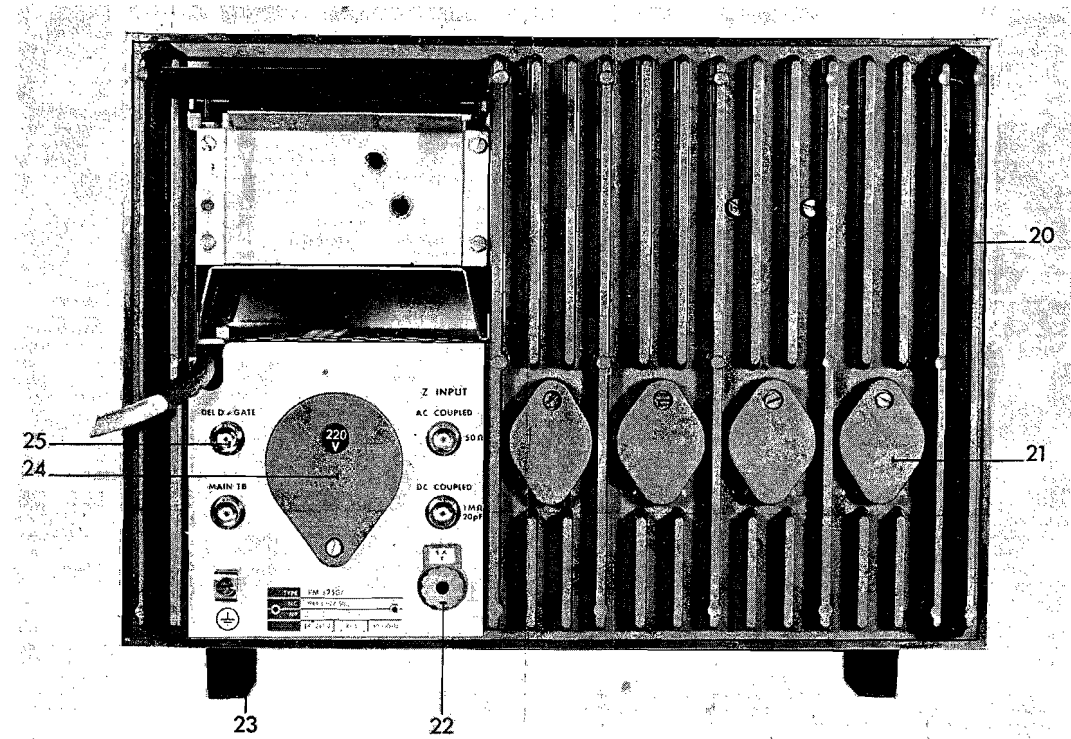

Fig. XIII-2. Rear side

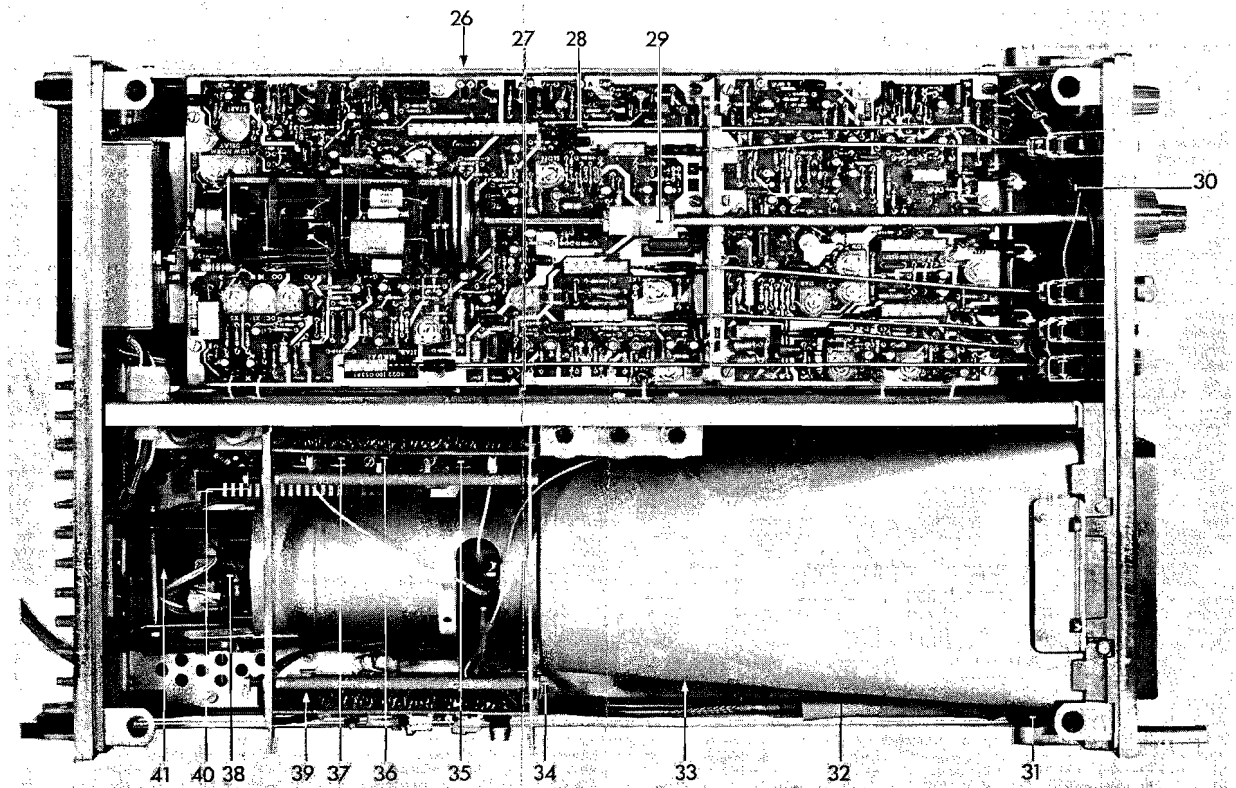

Fig. XIII-3. Top side

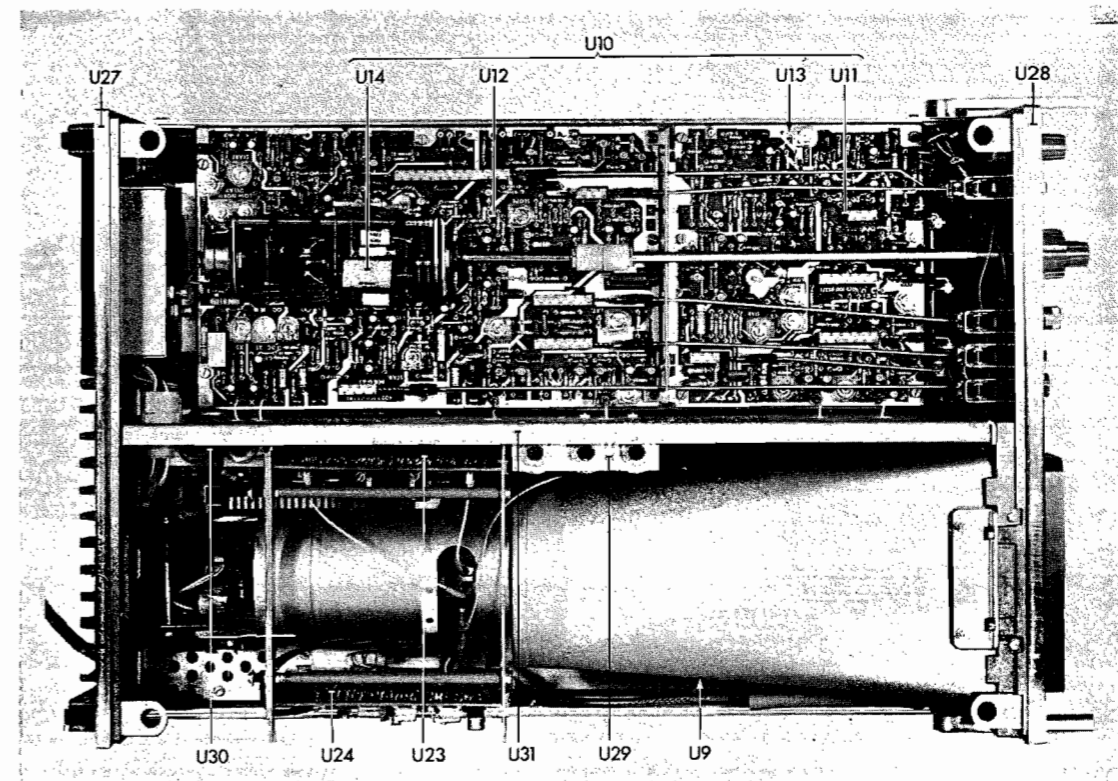
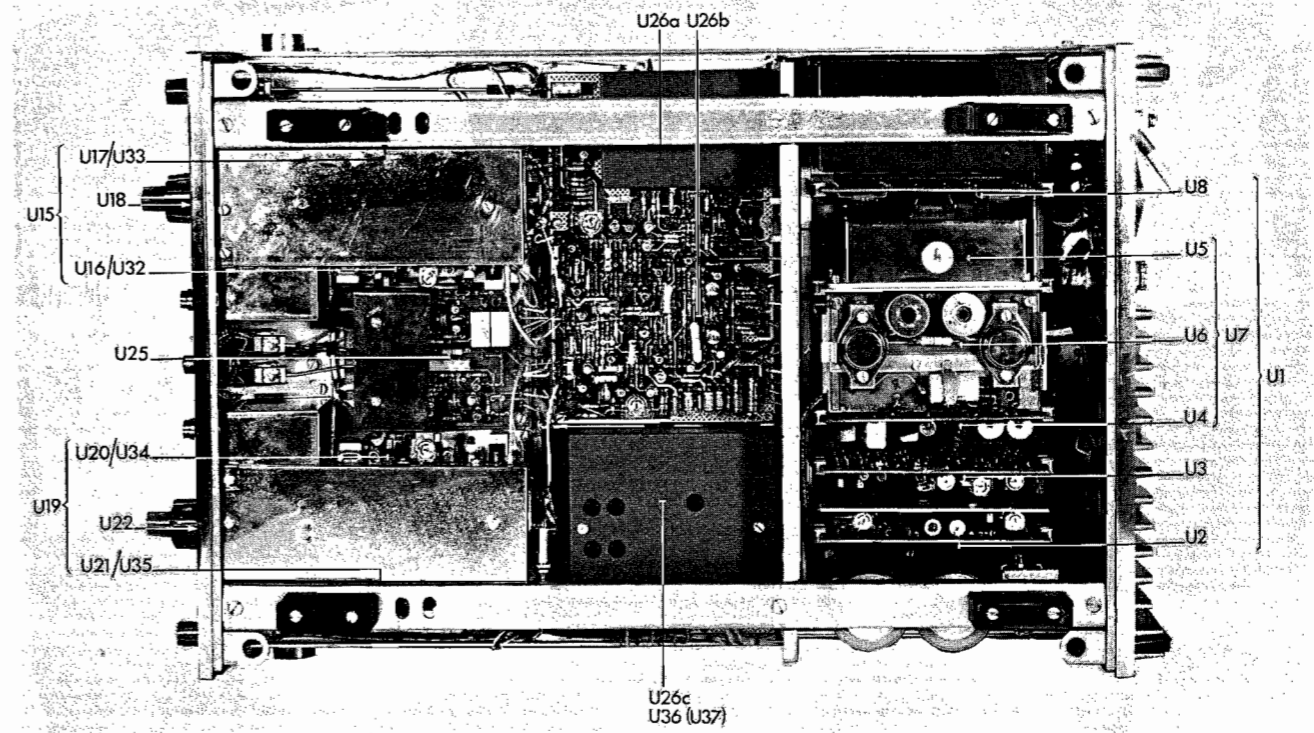

Fig. XIII-4. Top side



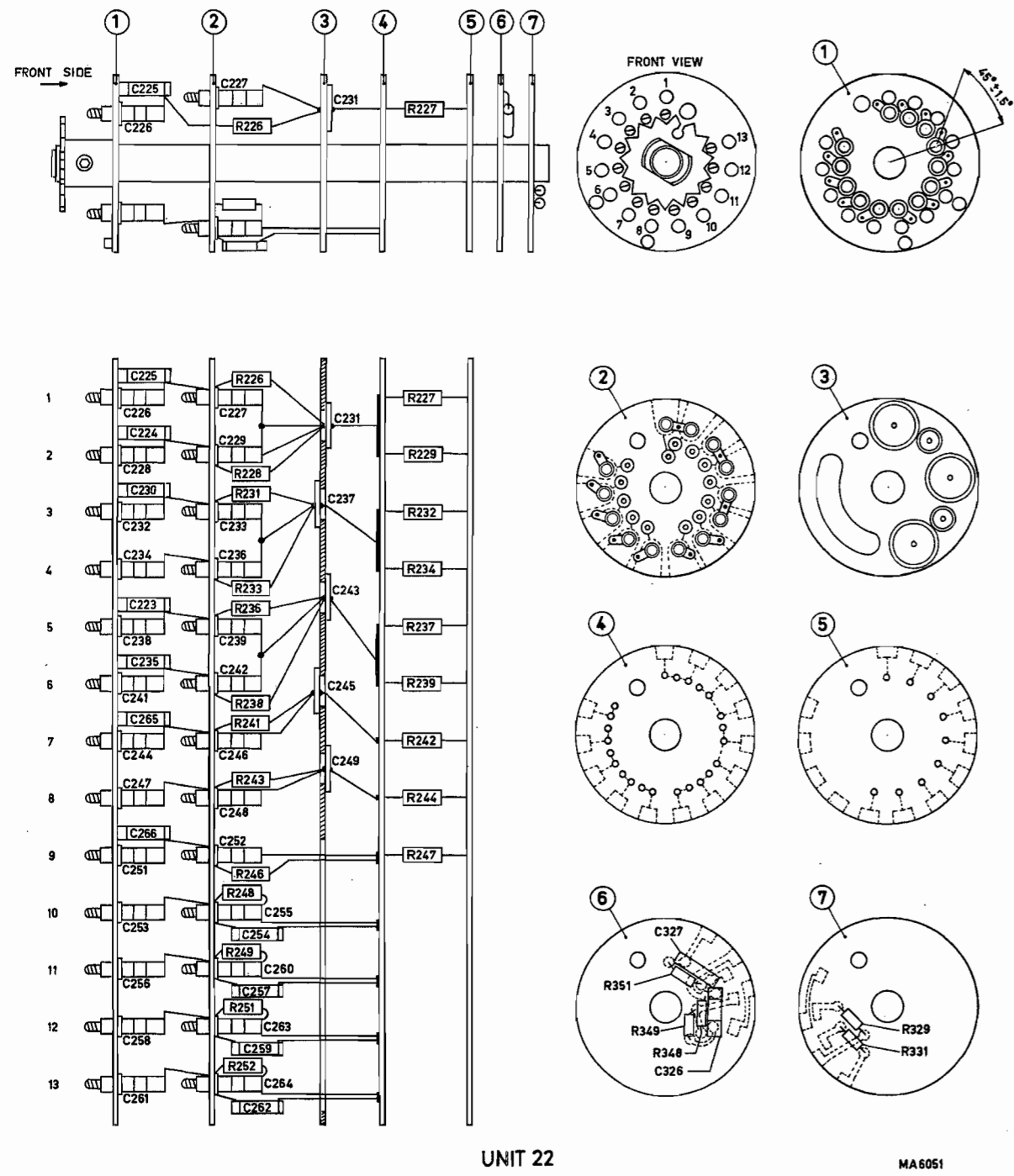

Fig. XIV-1a. Component location

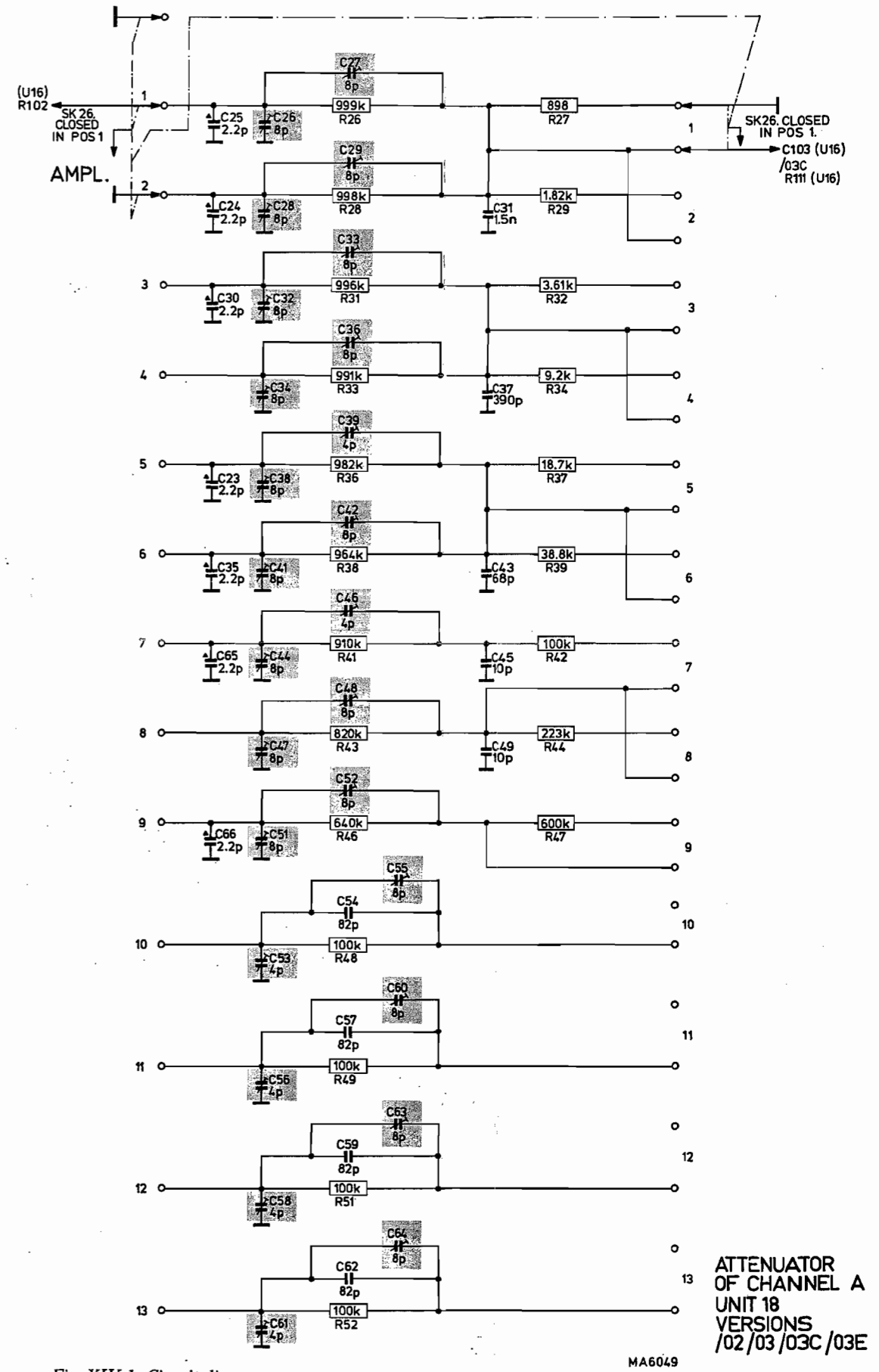

Fig. XIV-1. Circuit diagram

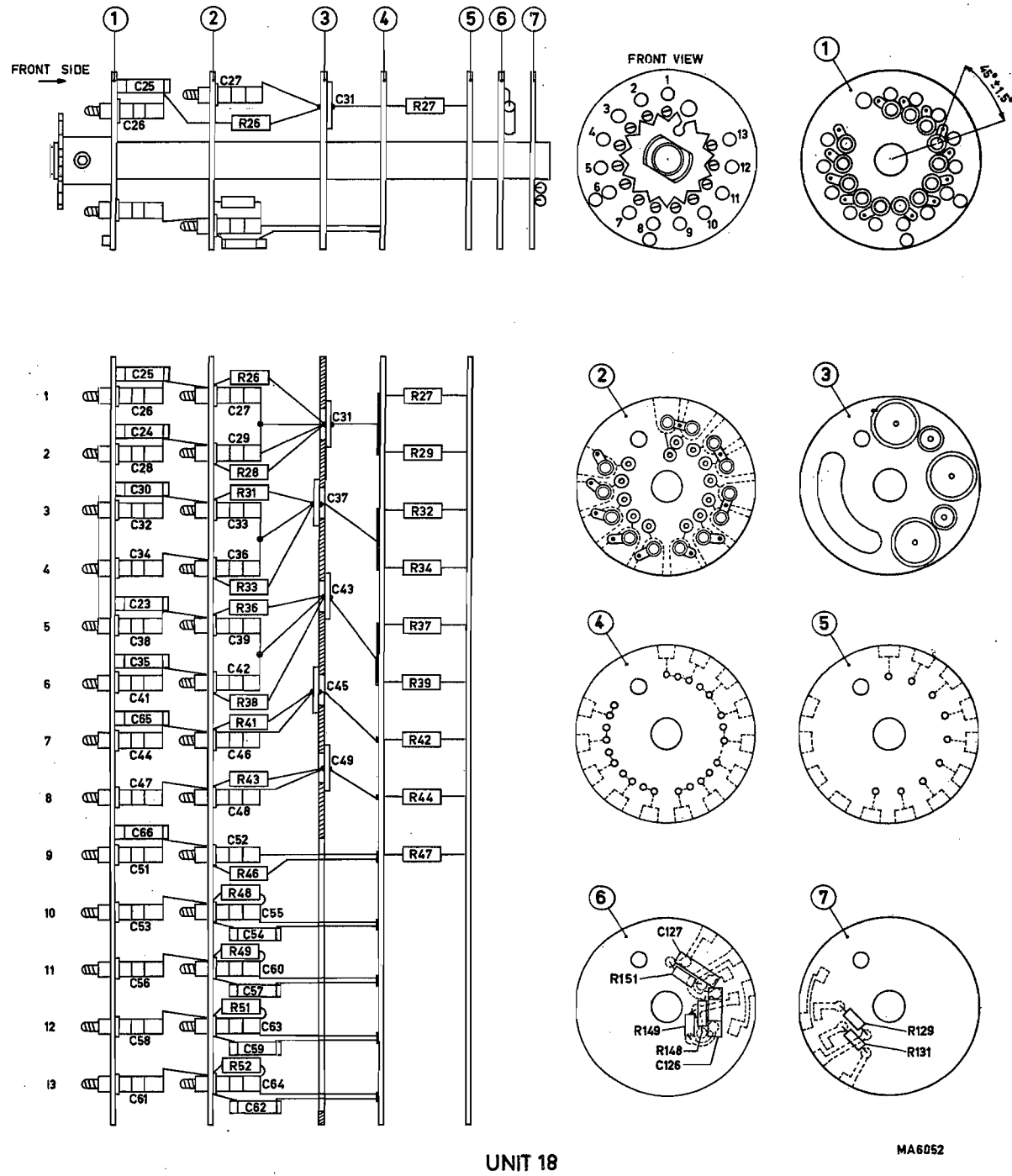

Fig. XIV-2a. Component location

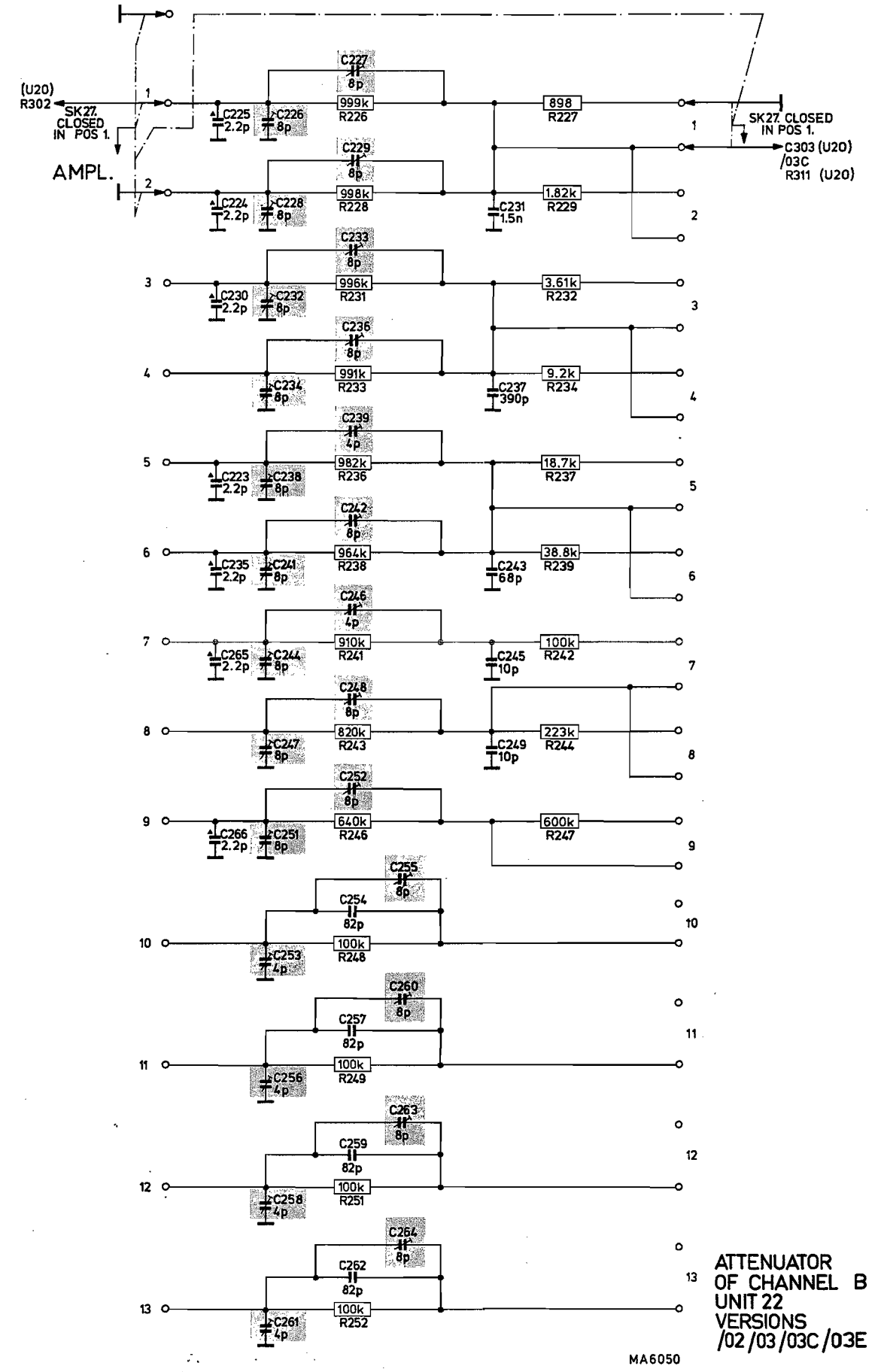

Fig. XIV-2. Circuit diagram

Attenuator switch B U22

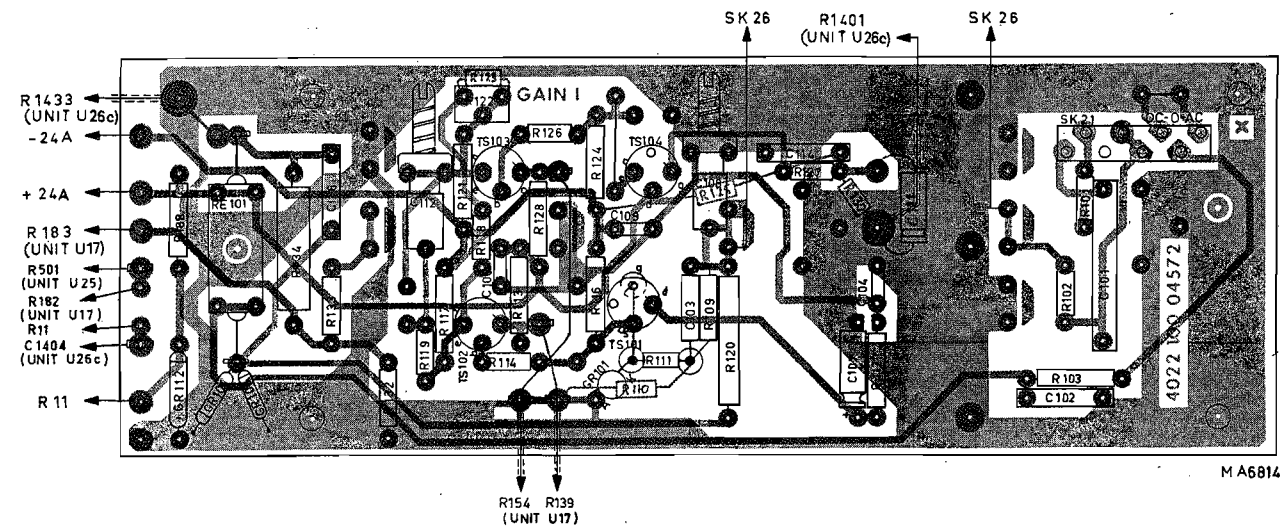

Fig. XIV-3a. Board 1

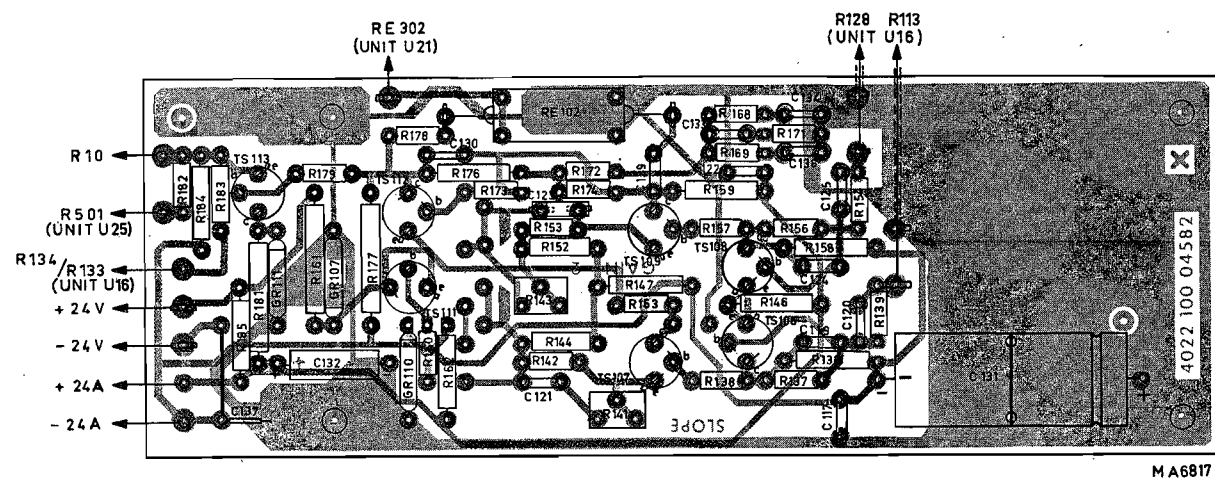
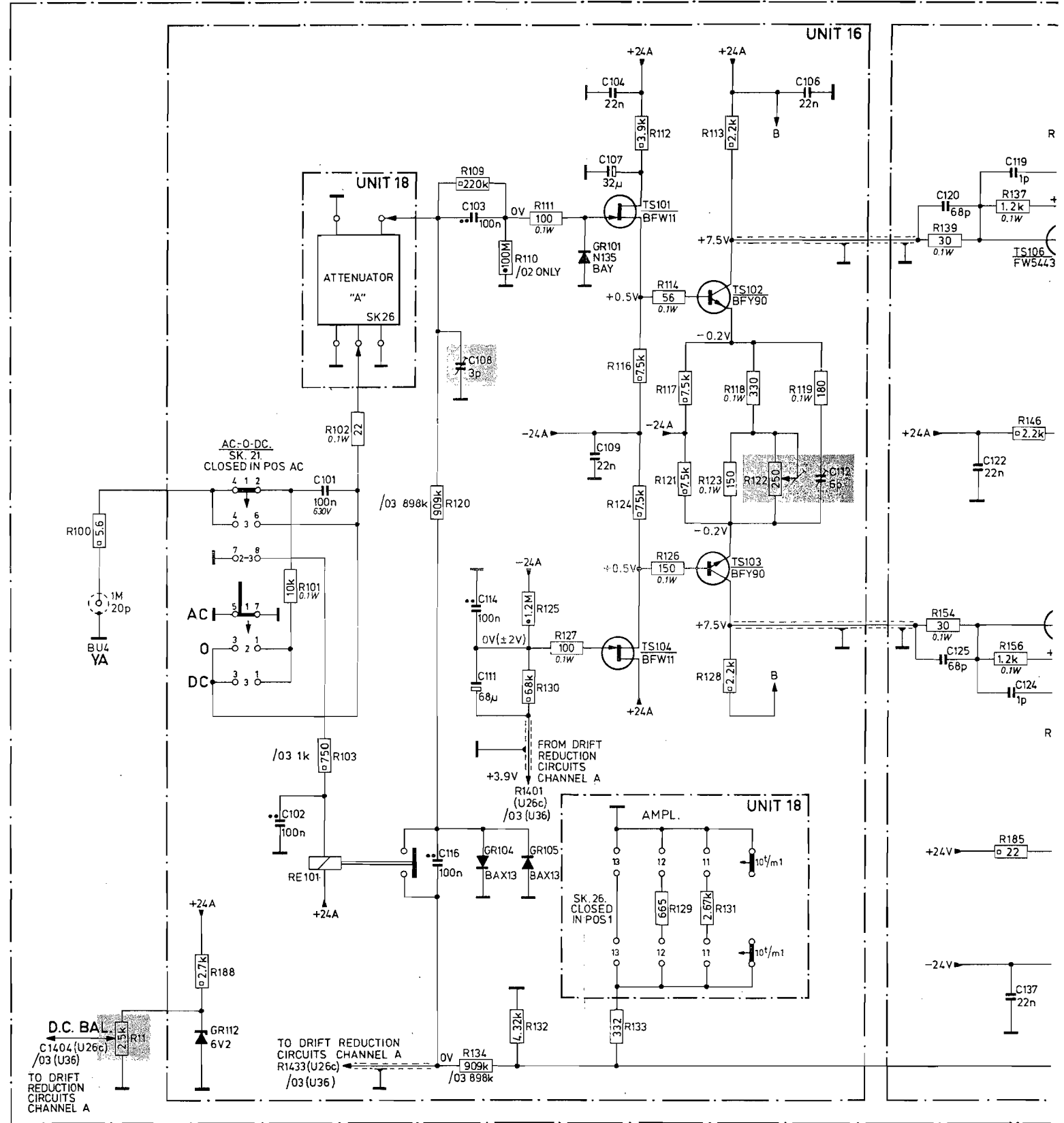
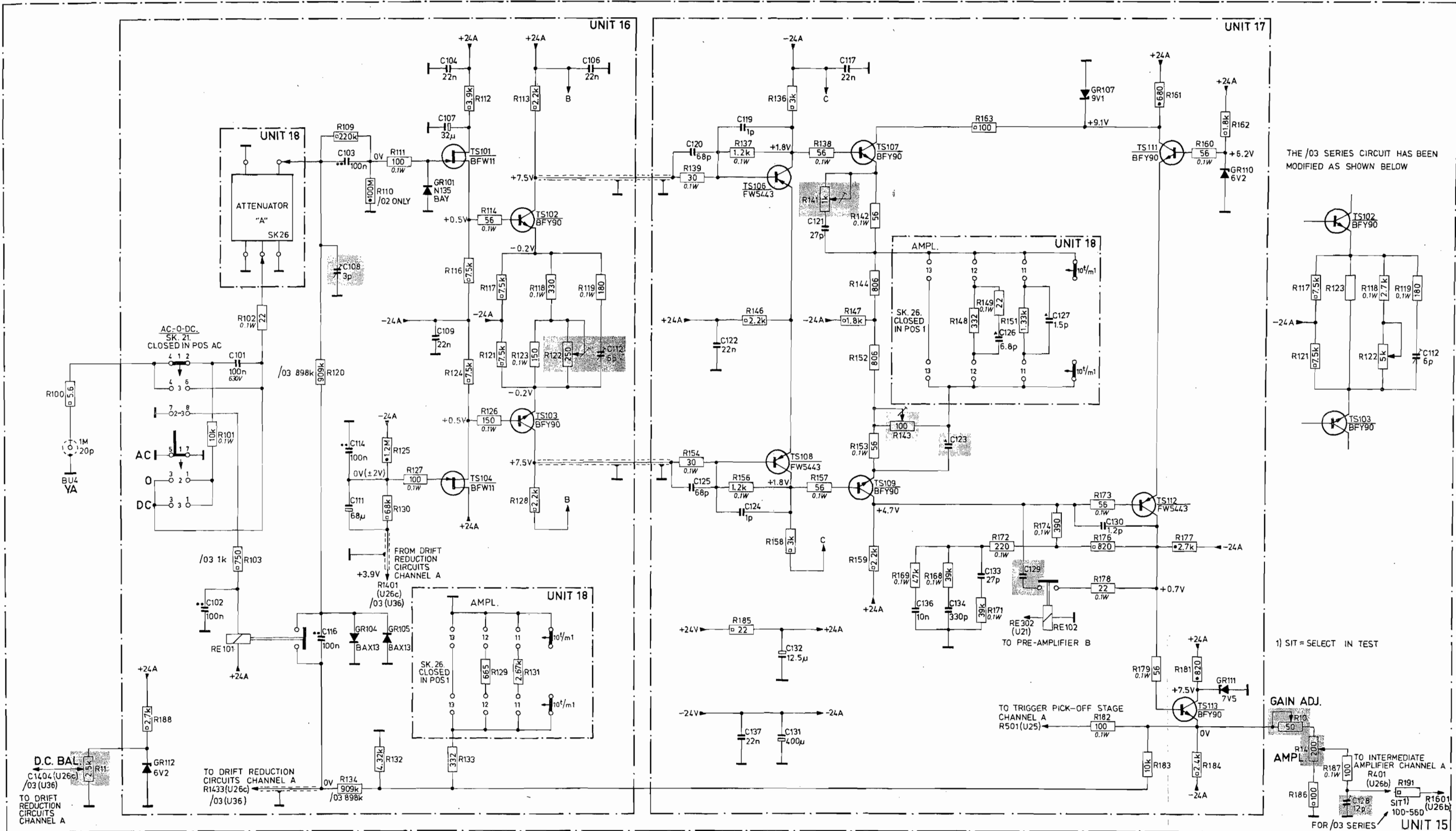

Fig. XIV-3b. Board 2

Component location





MA6047

Fig. XIV-3. Circuit diagram

Preamplifier A U15, vers. -/02/03/03E

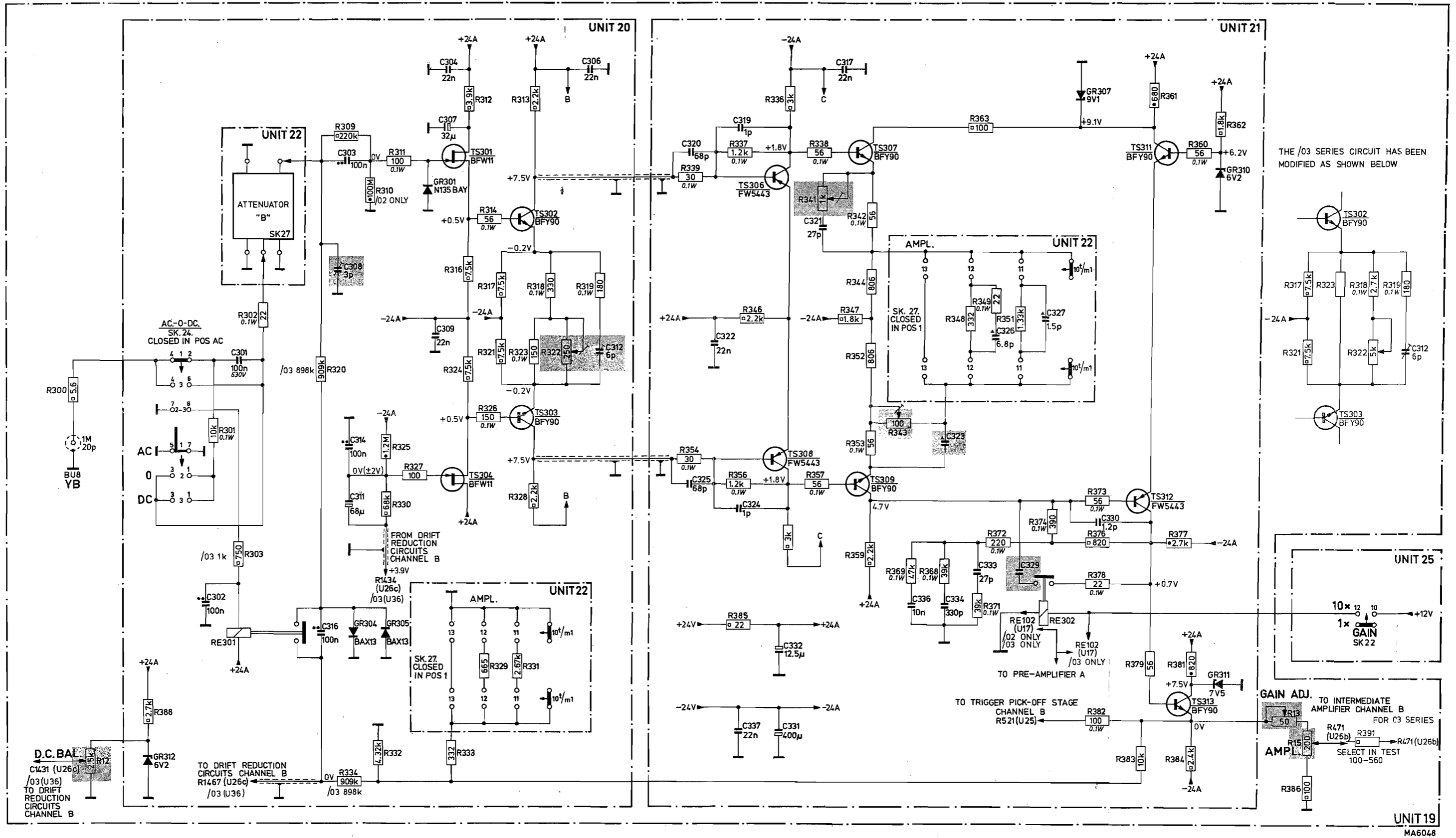

Fig. XIV-4. Circuit diagram

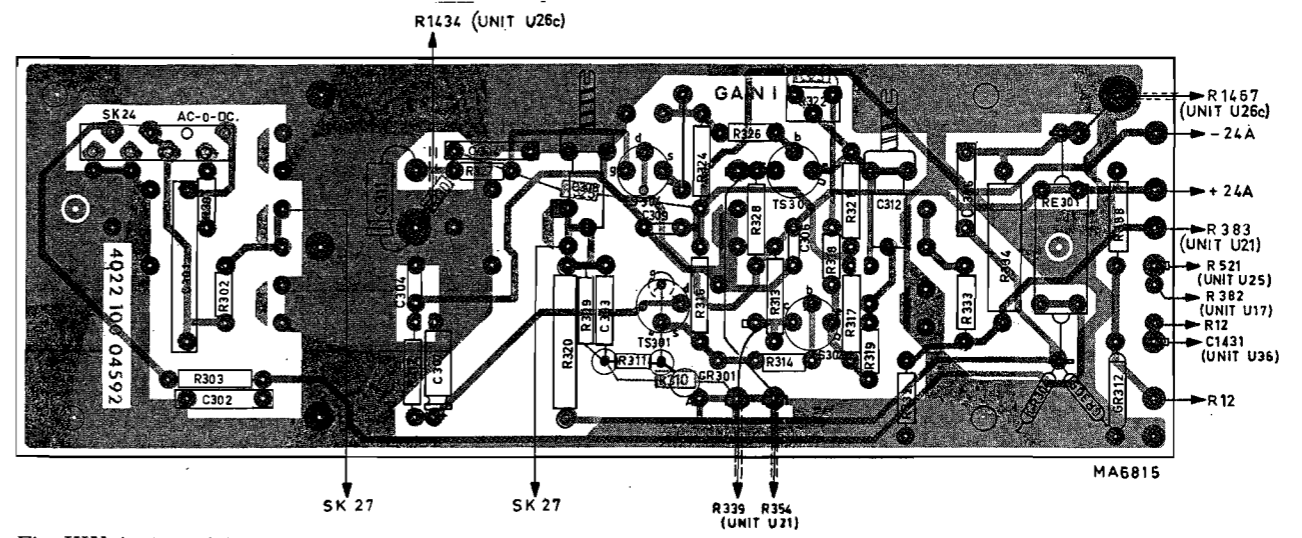
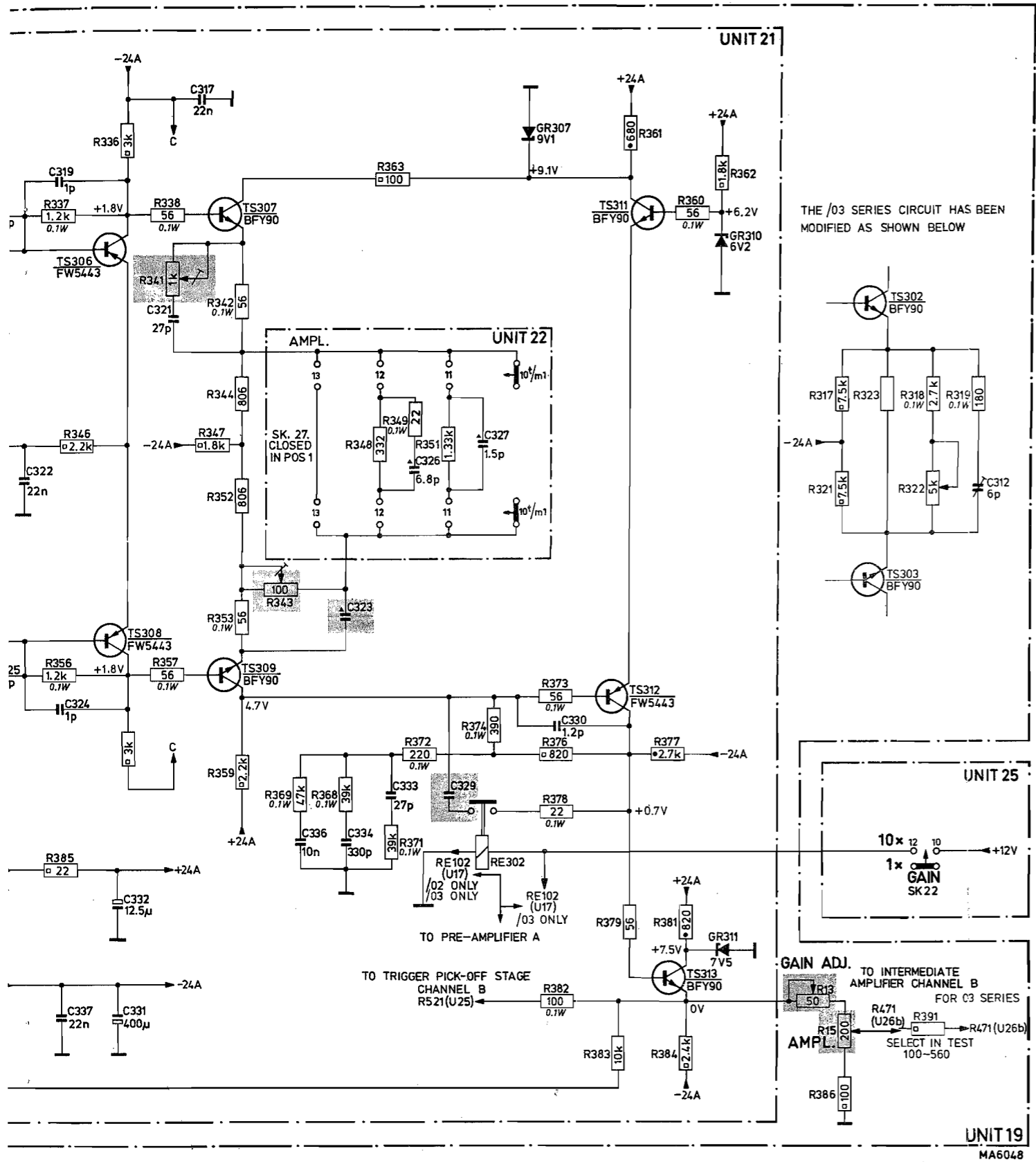

Fig. XIV-4a. Board 1

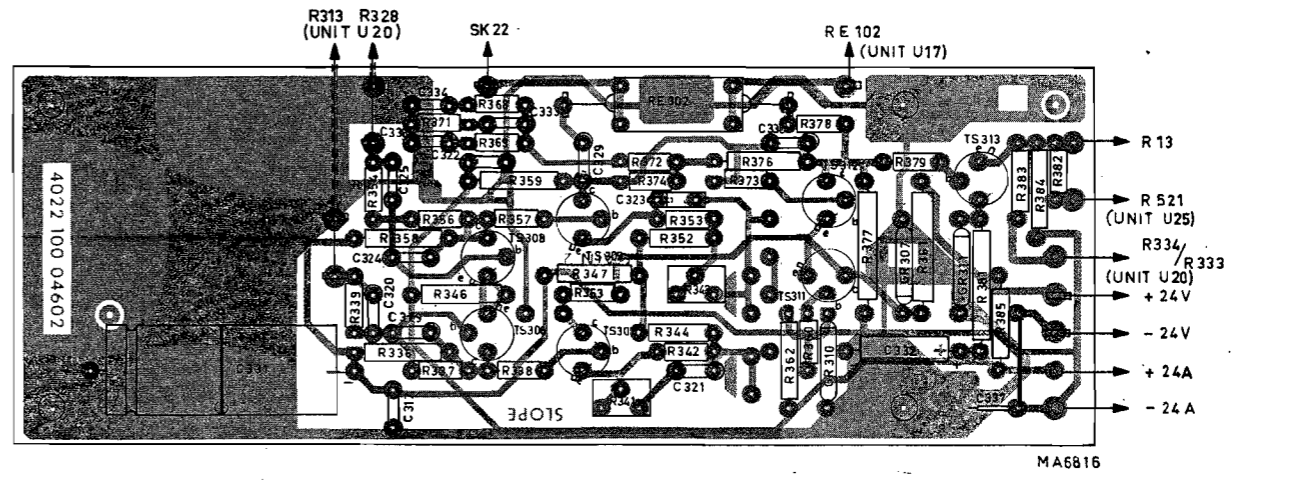

Fig. XIV-4b. Board 2

Component location

Preamplifier B U19, vers. -/02/03/03E



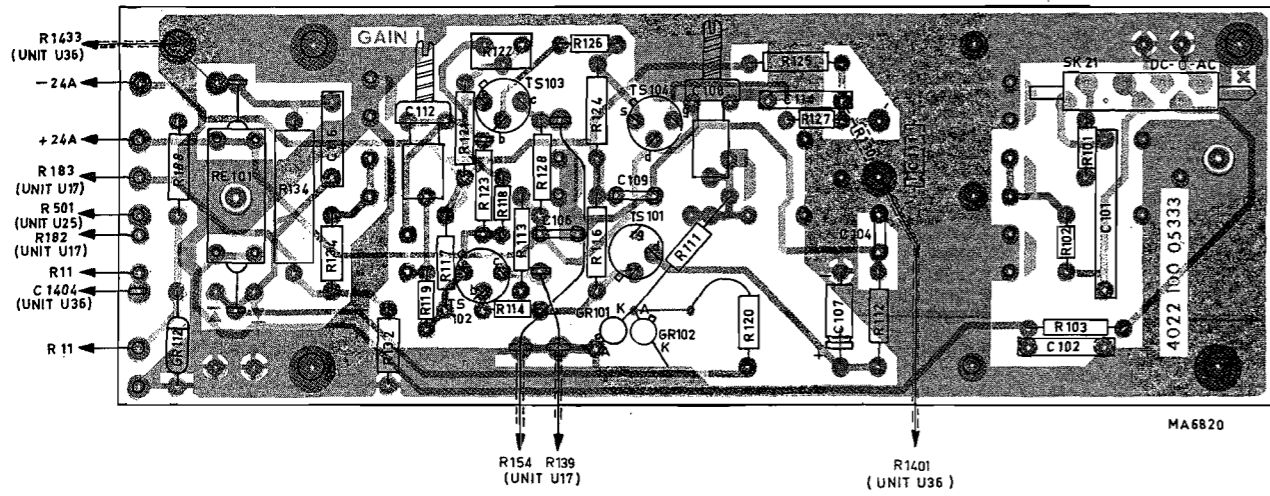

Fig. XIV-5a. Board 1

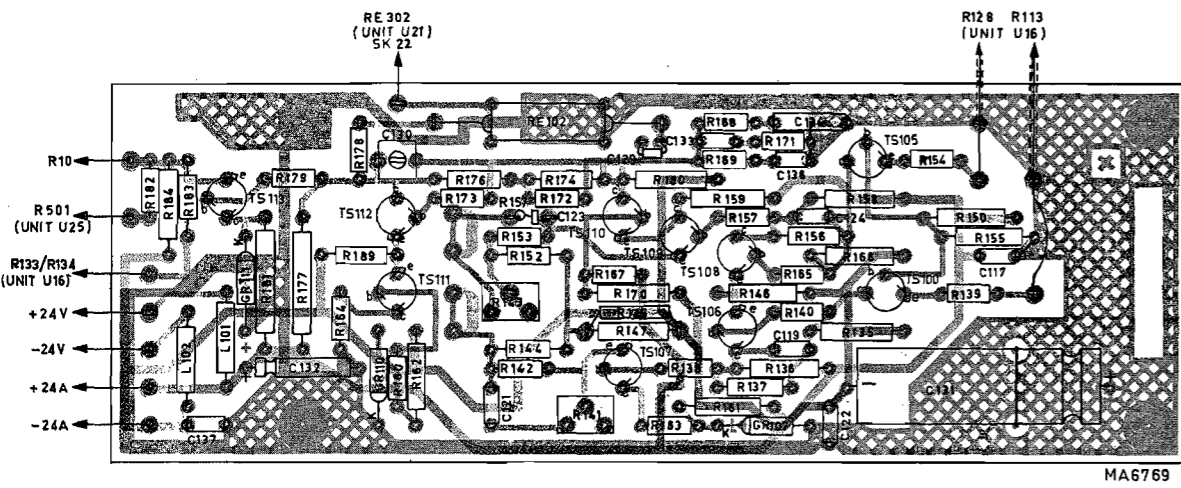
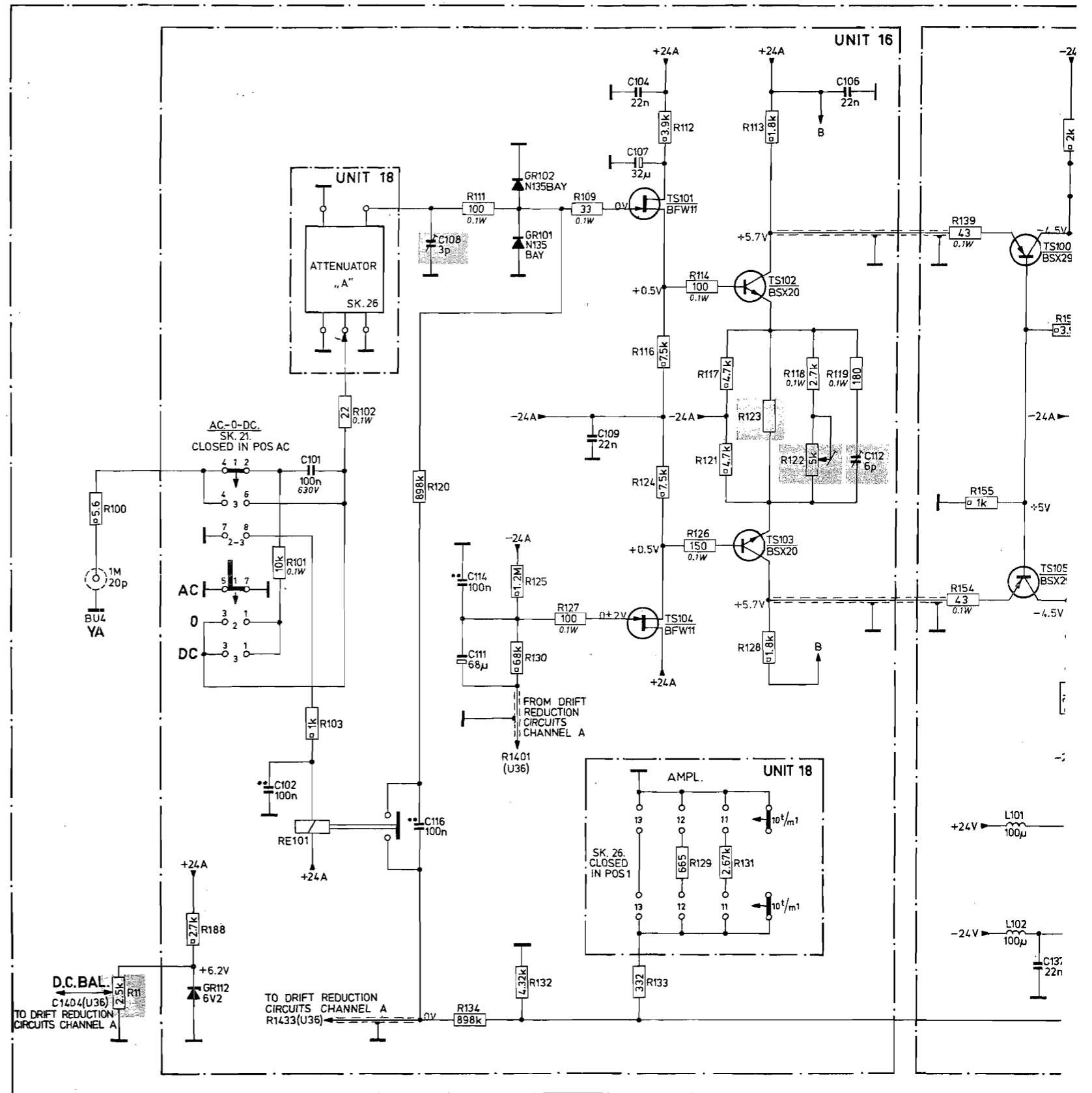

Fig. XIV-5b. Board 2

Component location



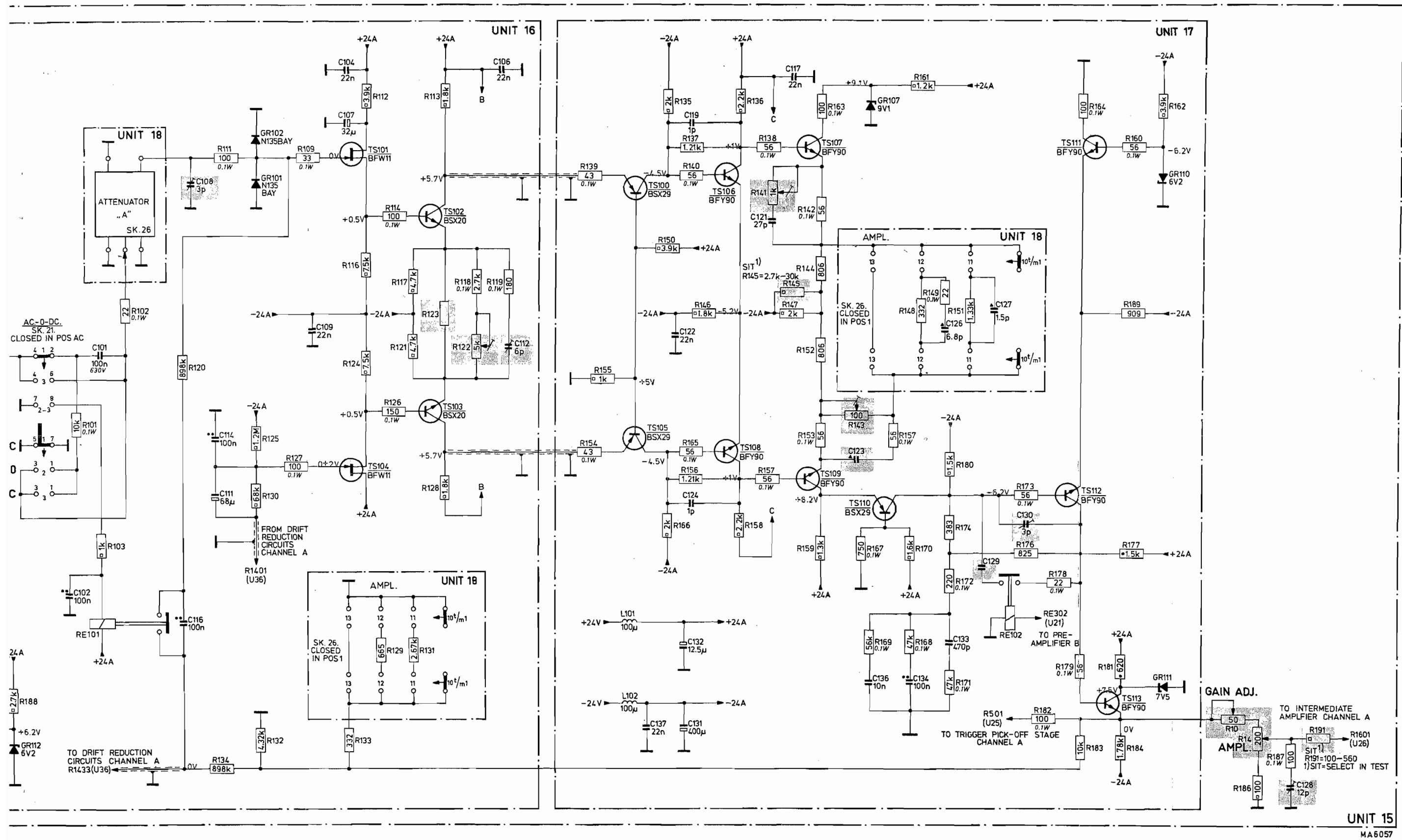

Fig. XIV-5. Circuit diagram

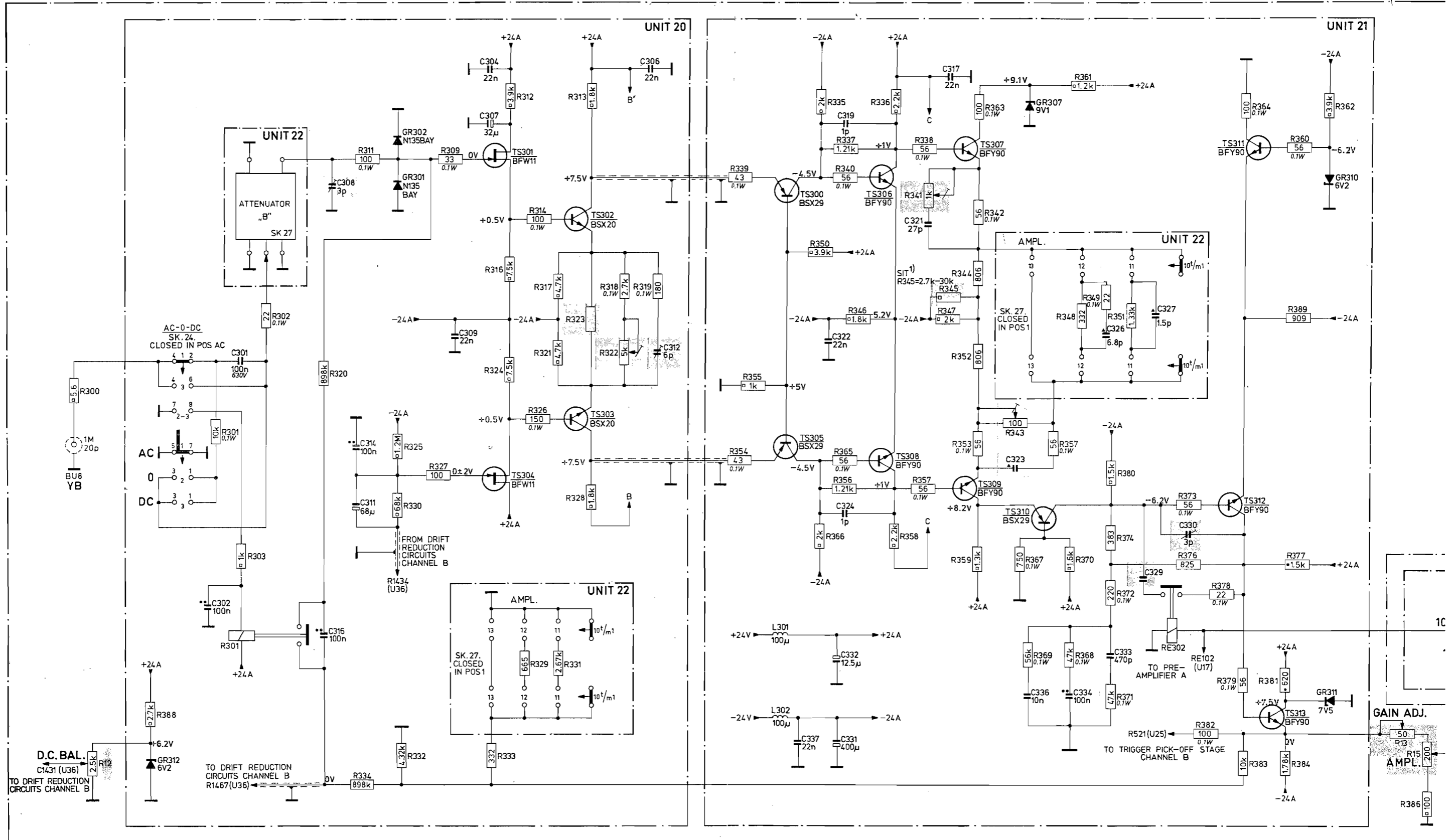

Fig. XIV-6. Circuit diagram

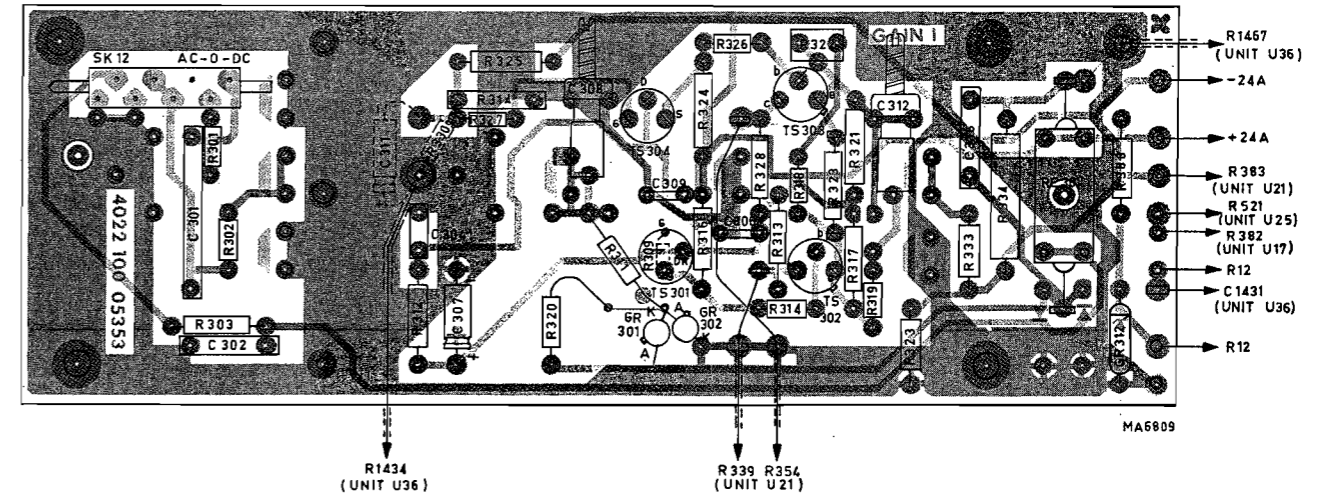
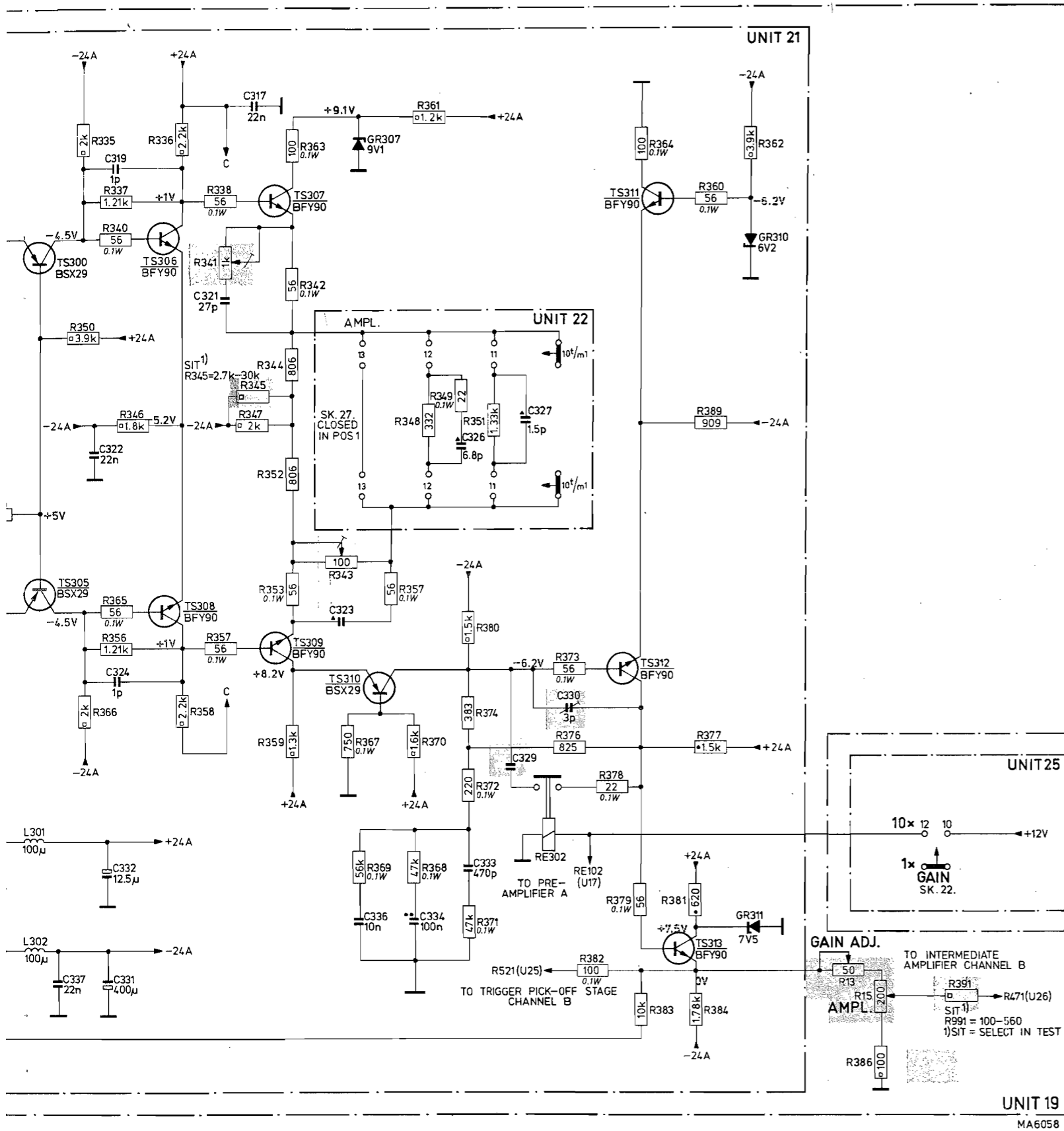

Fig. XIV-6a. Board 1

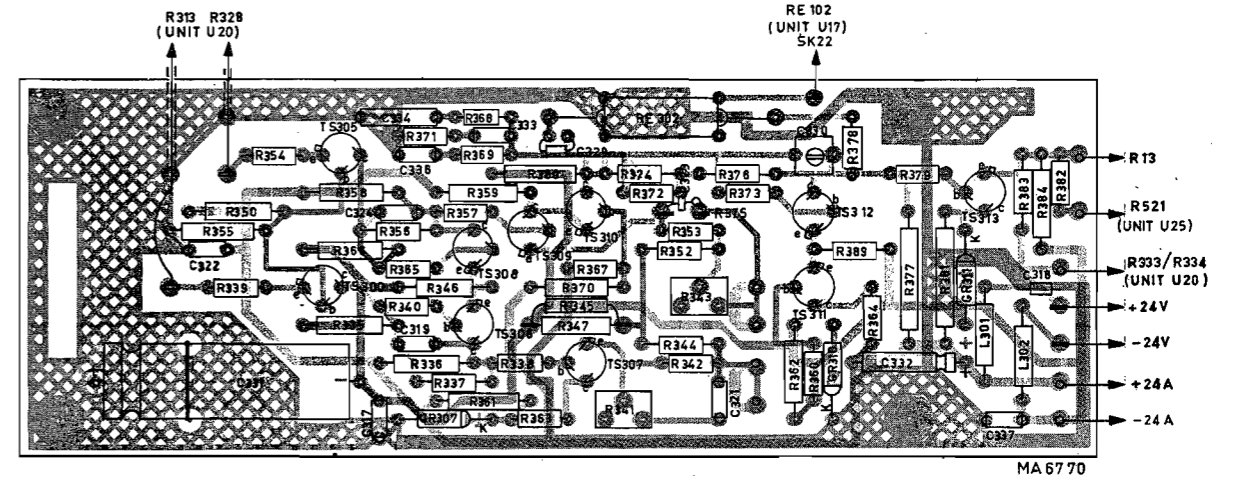
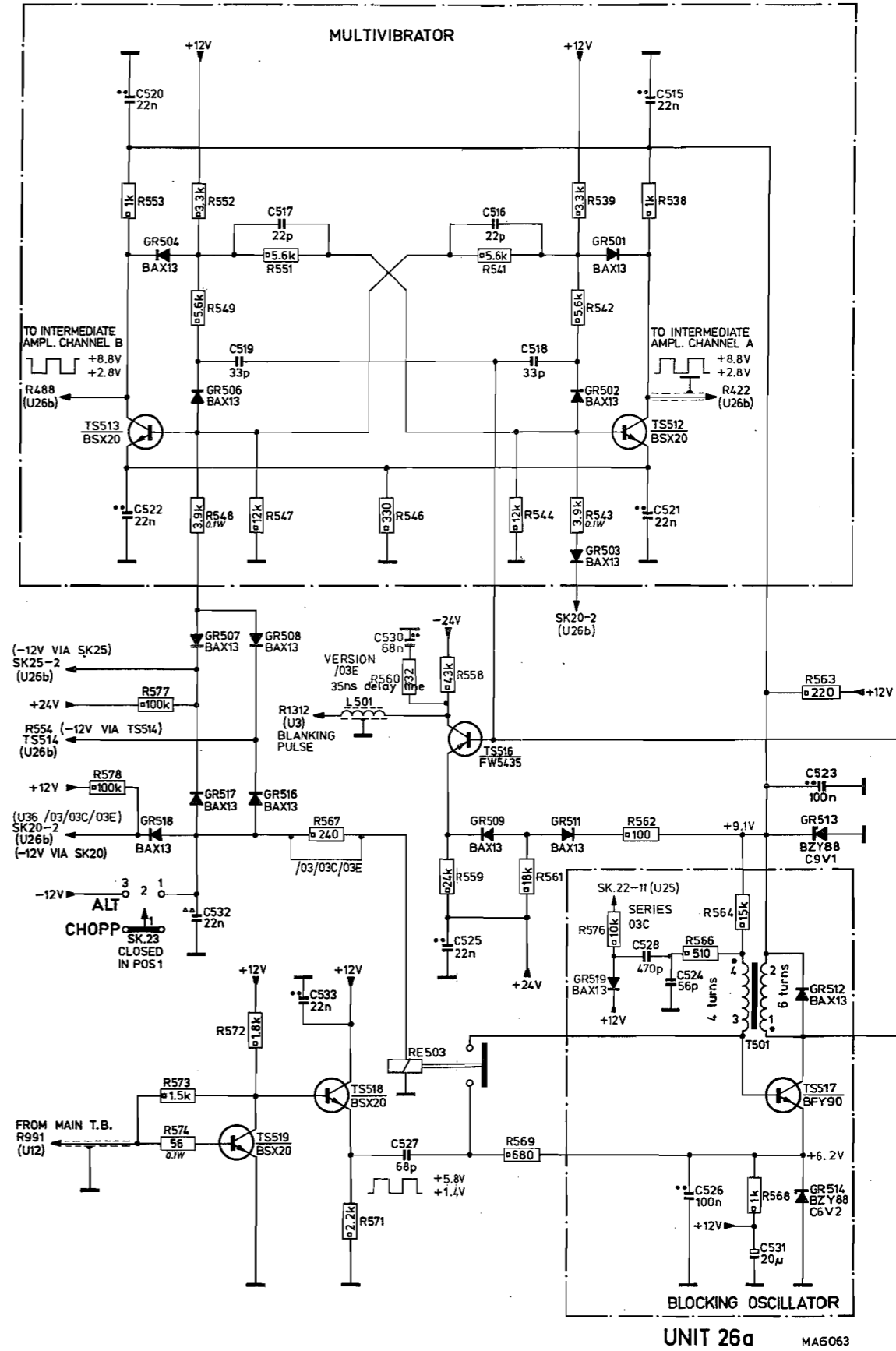

Fig. XIV-6b. Board 2

Component location

Preamplifier B U19, vers. -/03C/03E



XIV-7. Circuit diagram

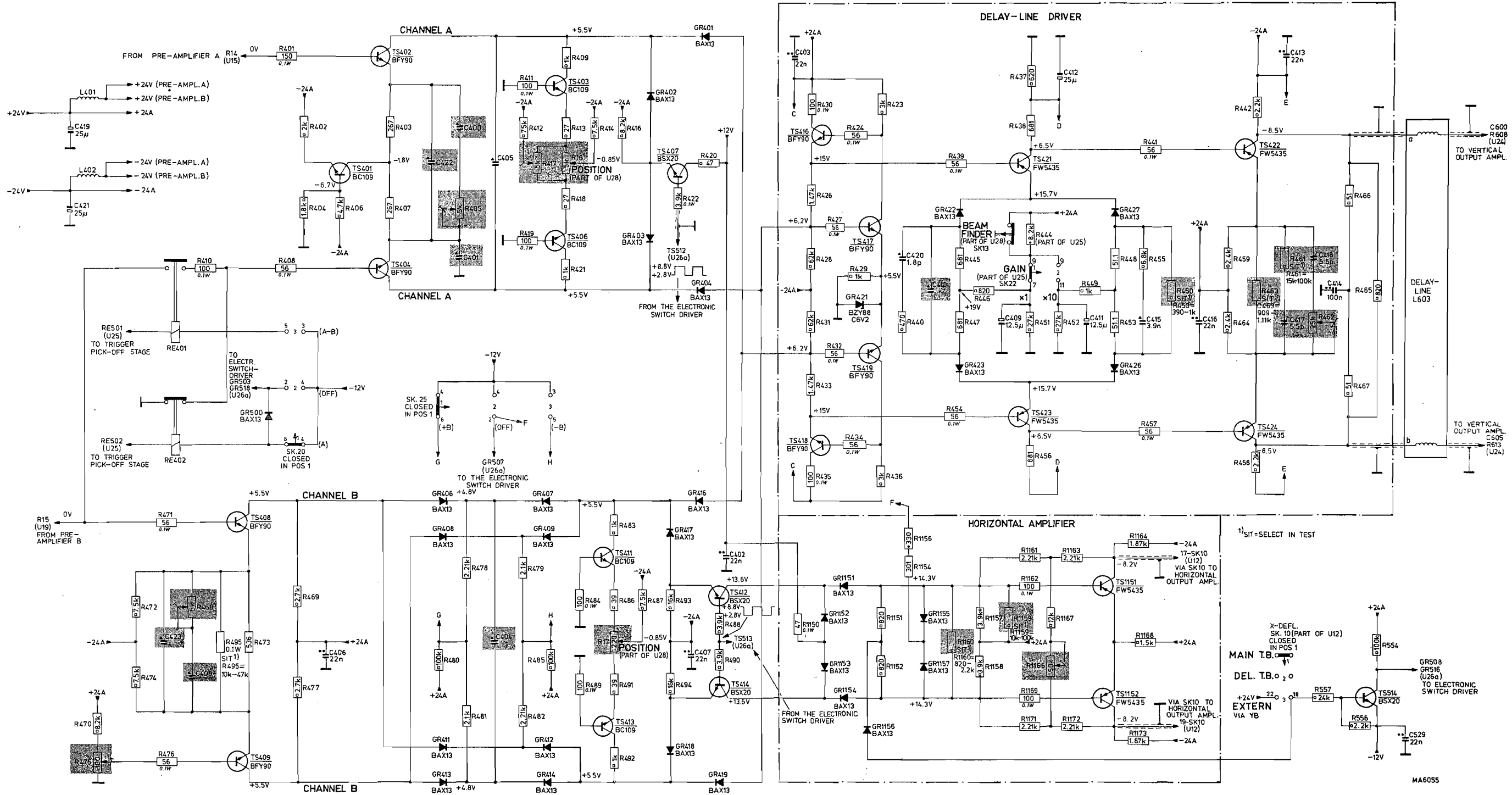

Fig. XIV-8. Circuit diagram

Intermediate amplifier U26b, vers. -/02

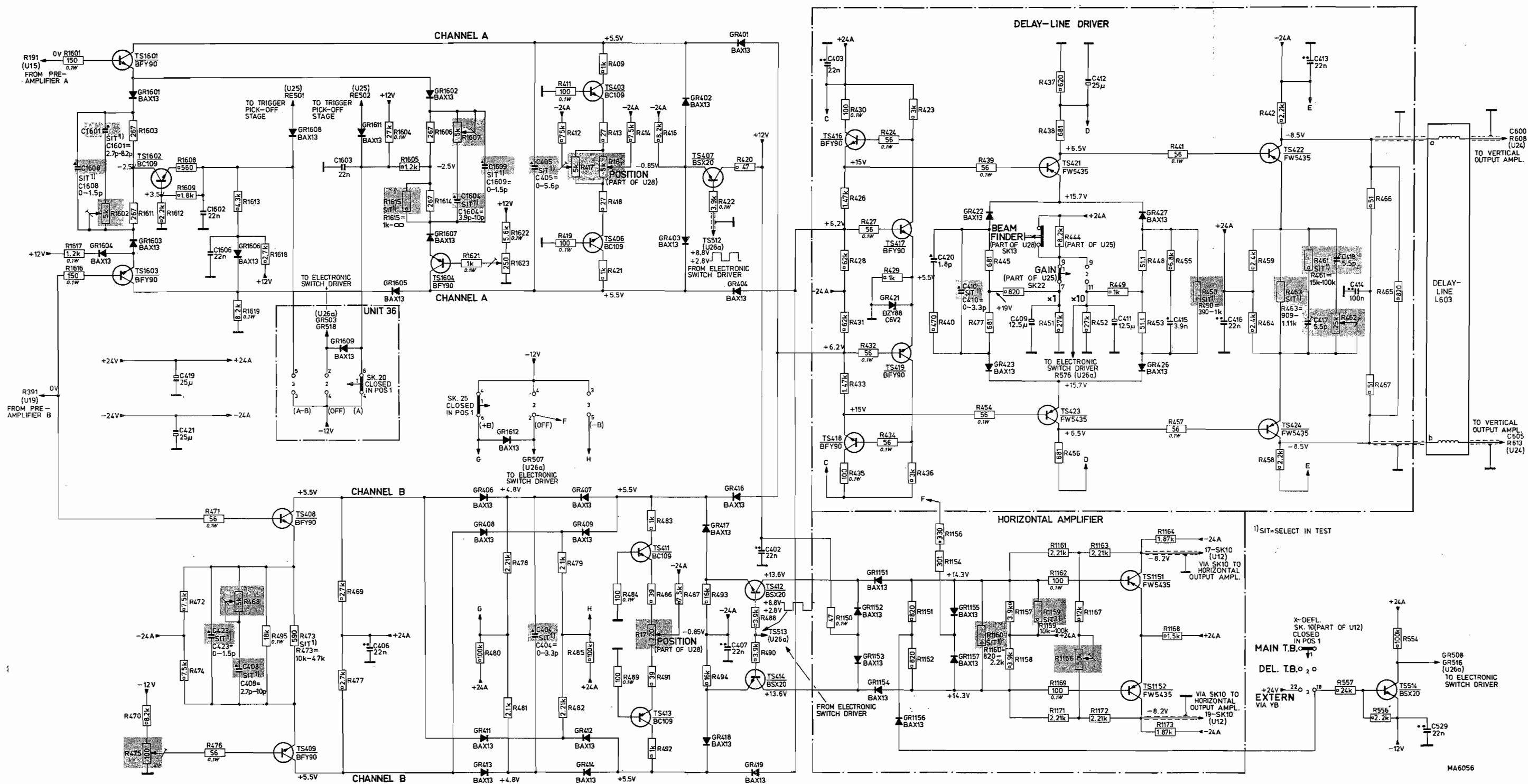

Fig. XIV-9. Circuit diagram

Intermediate amplifier U26b, vers. -/03/03C/03E

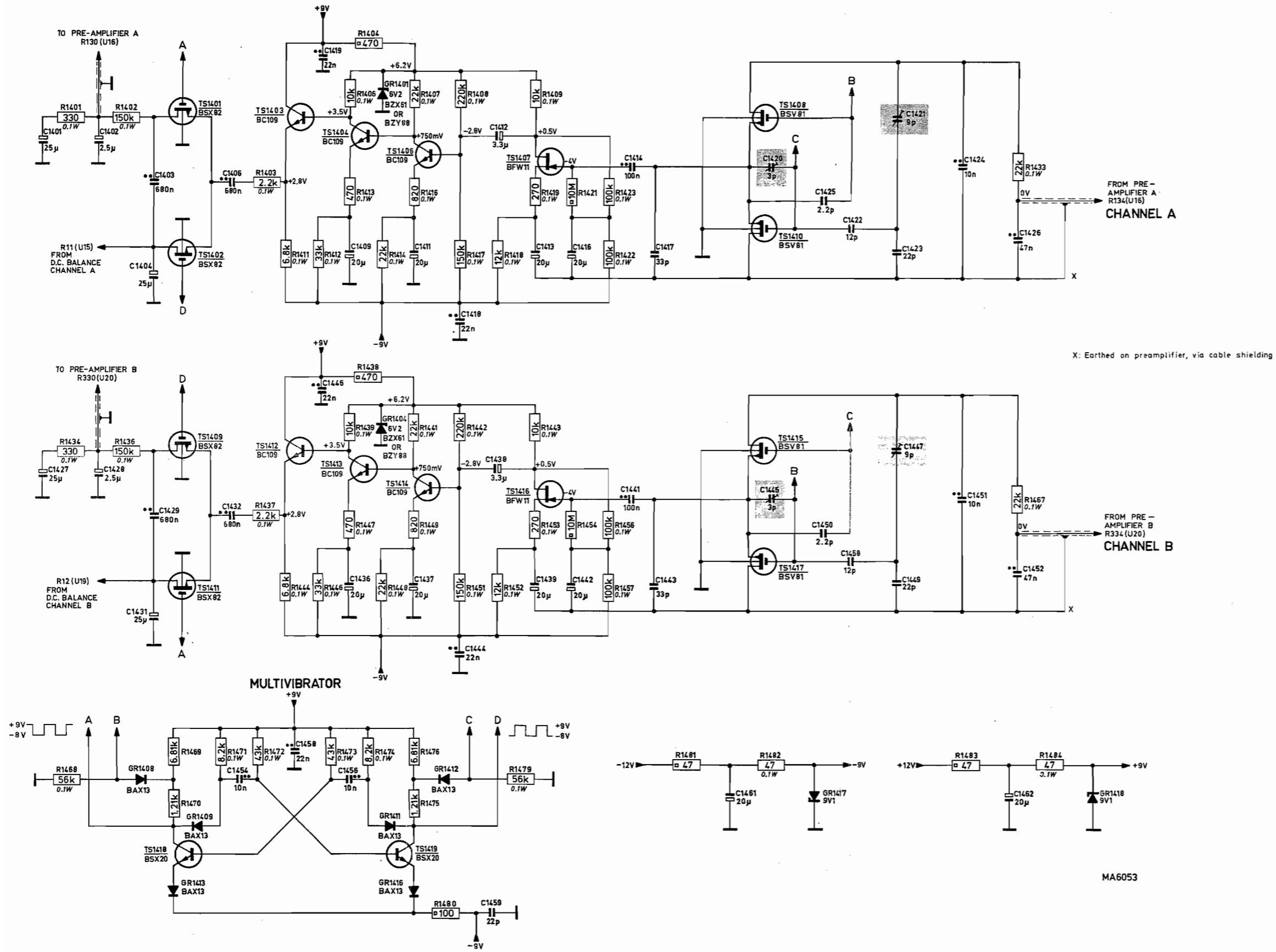

Fig. XIV-10. Circuit diagram

Drift reduction circuits, U26c, vers. -/02



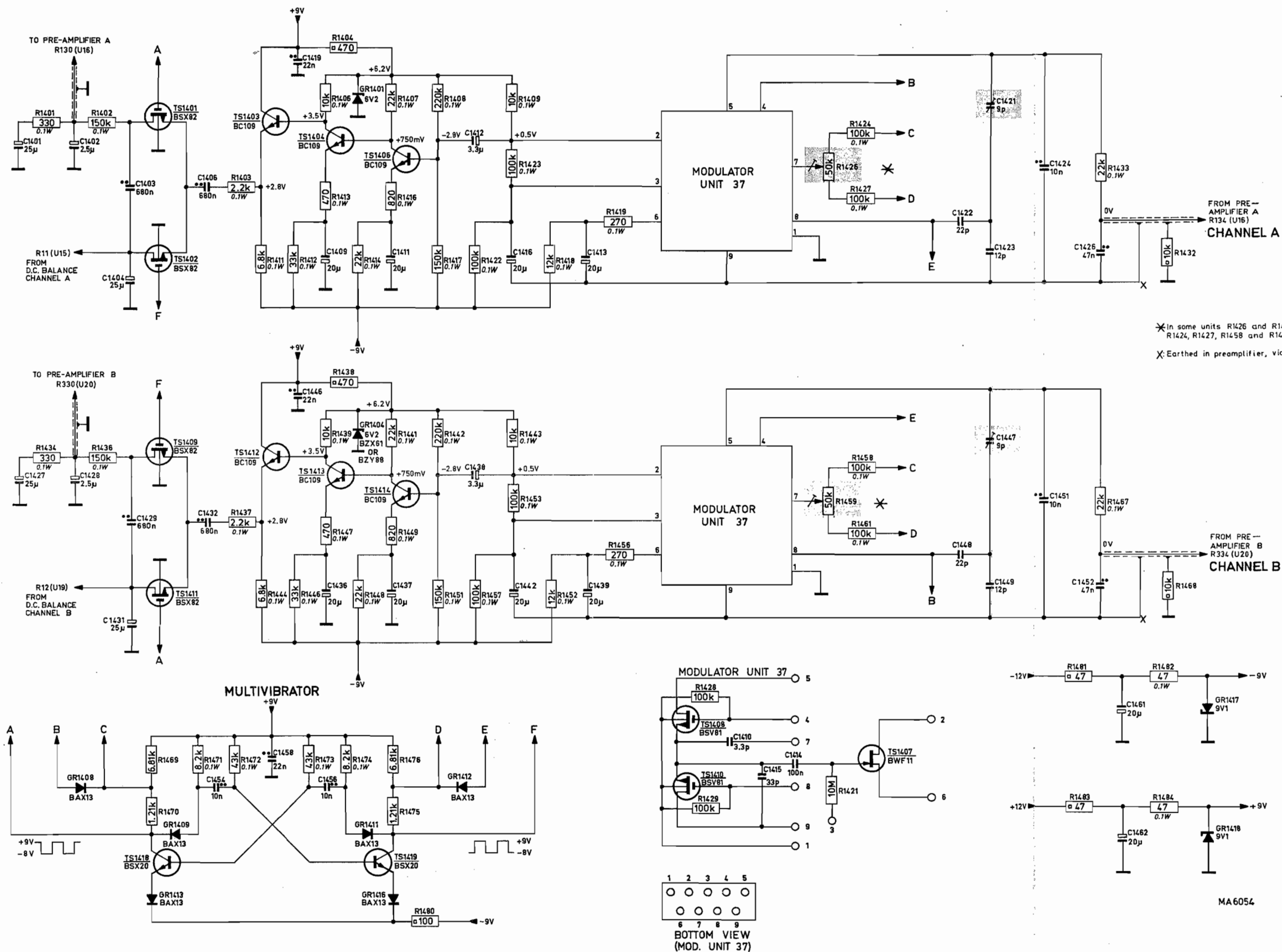

Fig. XIV-11. Circuit diagram

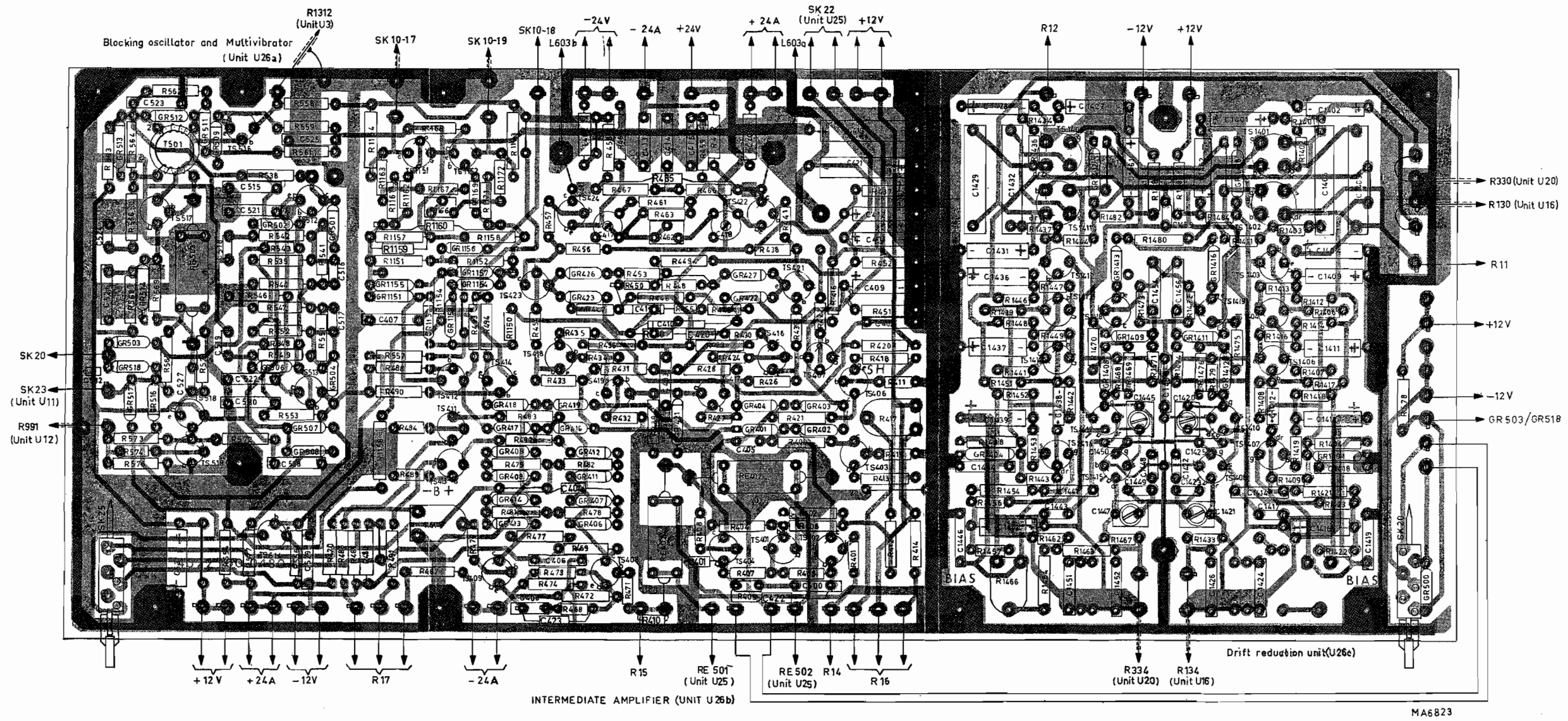

Fig. XIV-12. Component location

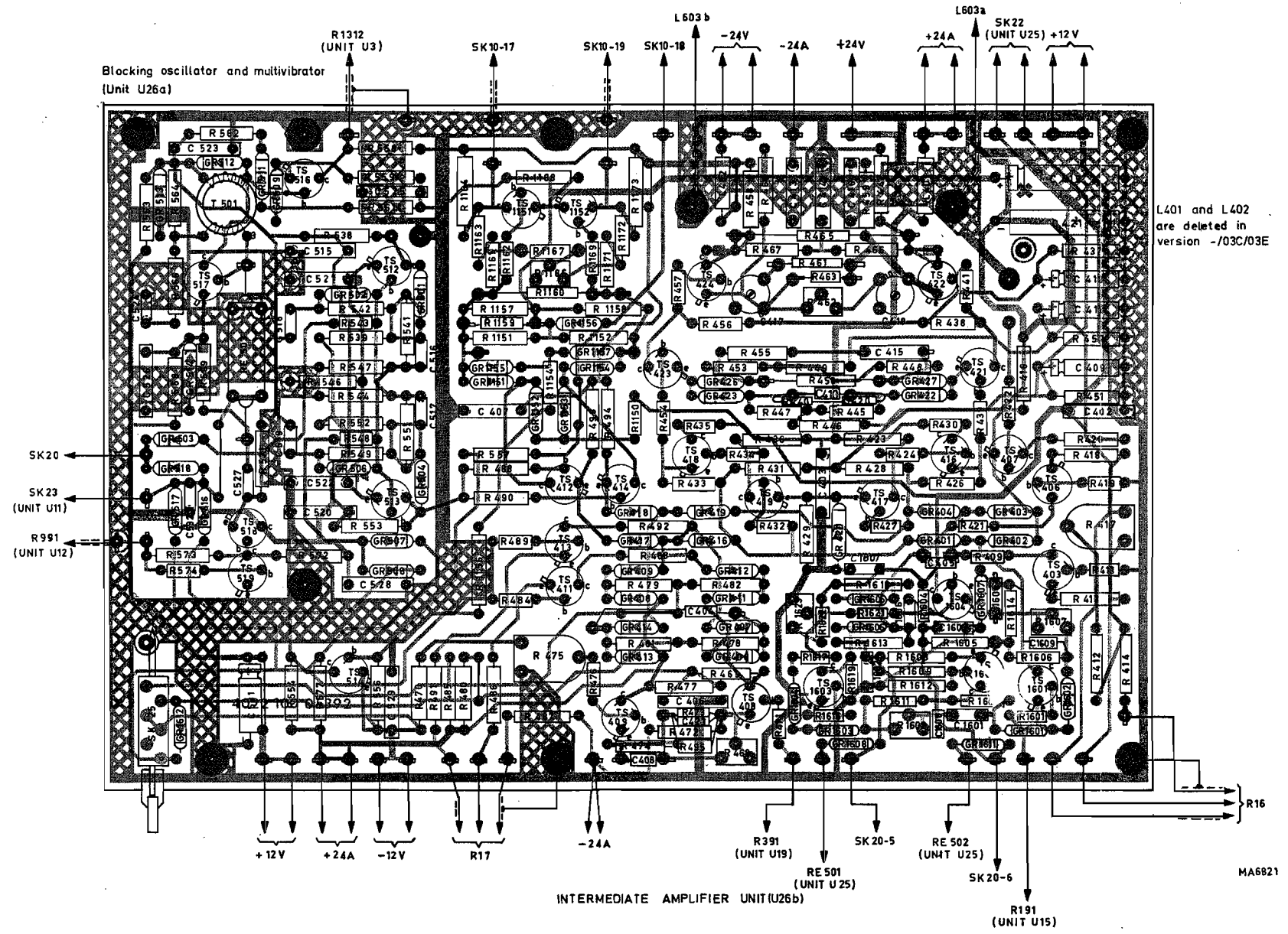

Fig. XIV-13

Electronic switch driver and intermediate amplifier U26a, b

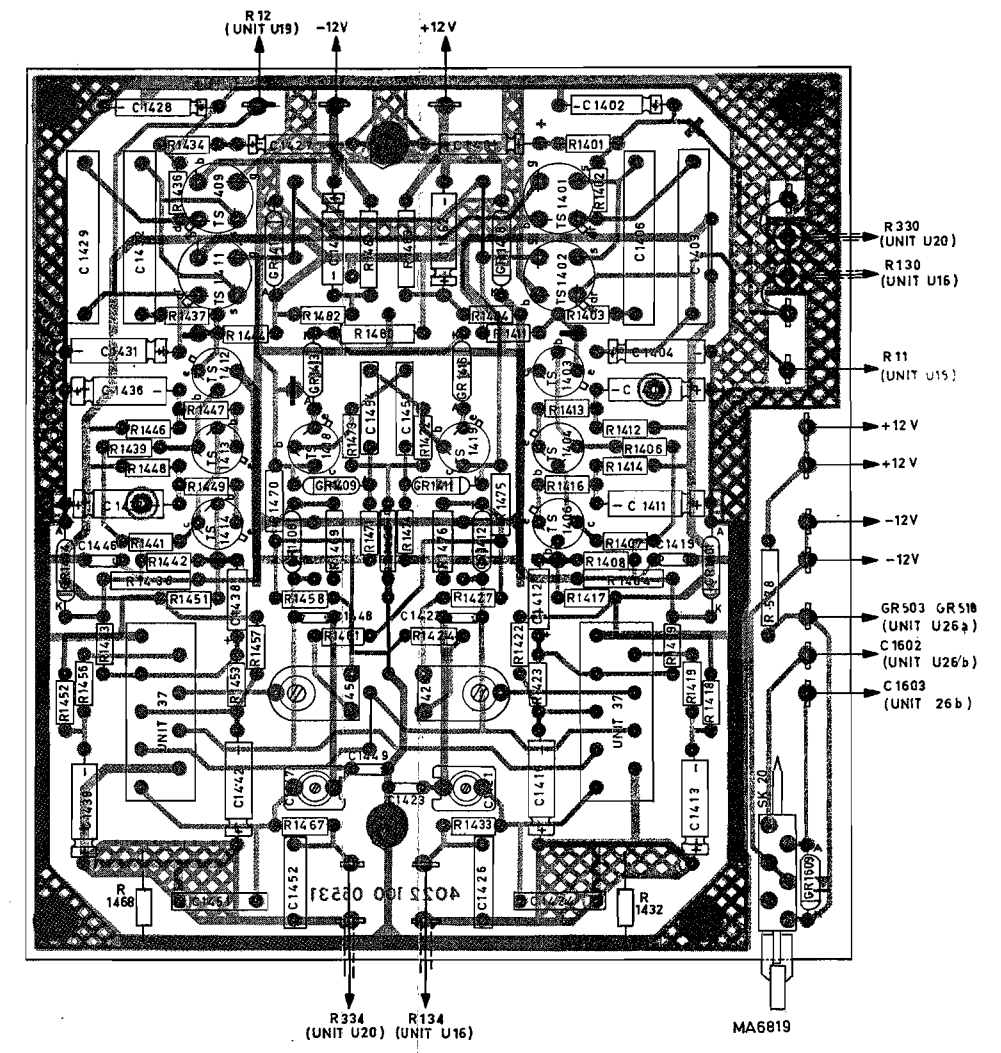

Fig. XIV-13a

Drift reduction circuits U36

Component location vers. -/03/03C/03E

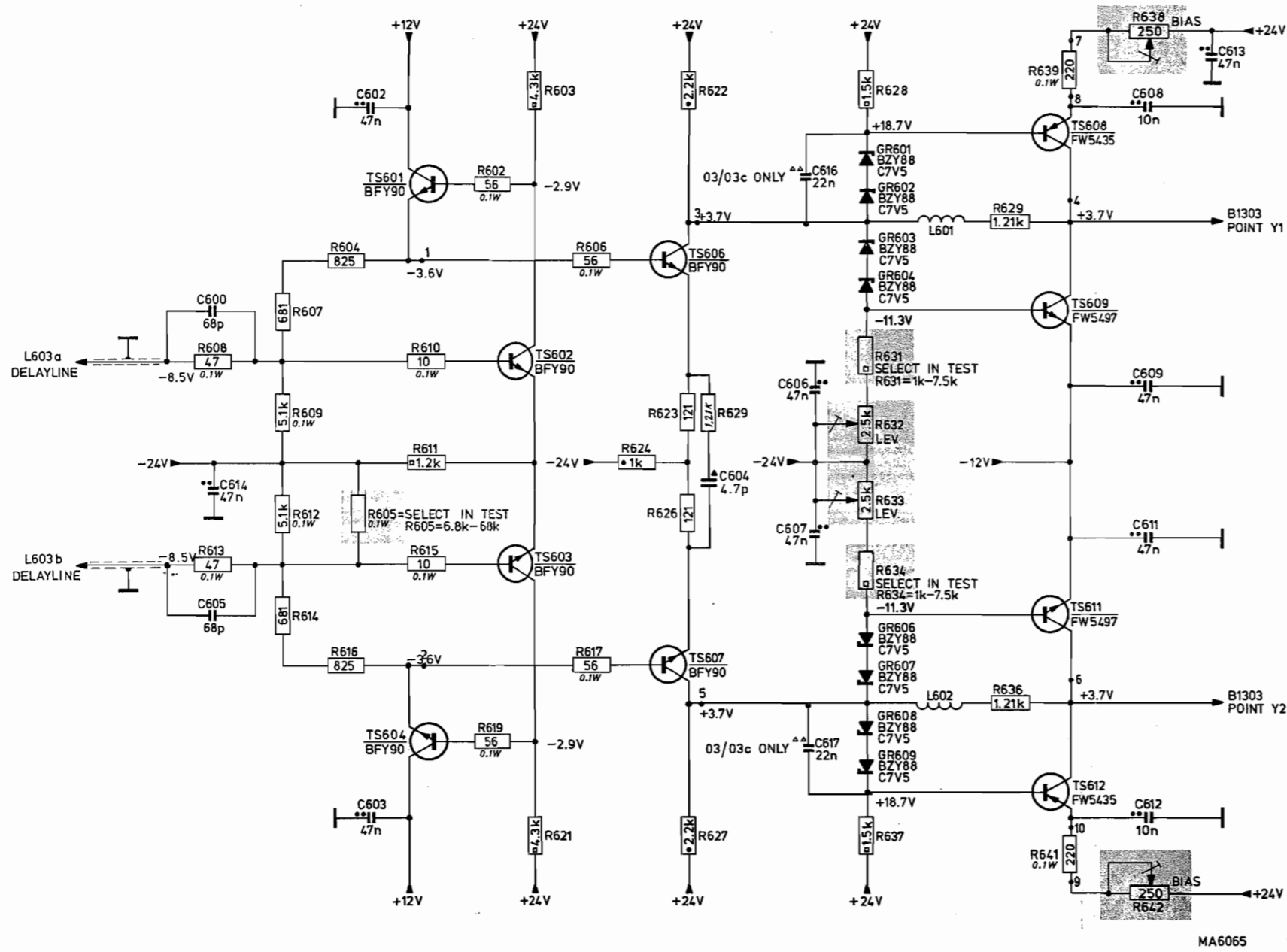

Fig. XIV-14. Circuit diagram

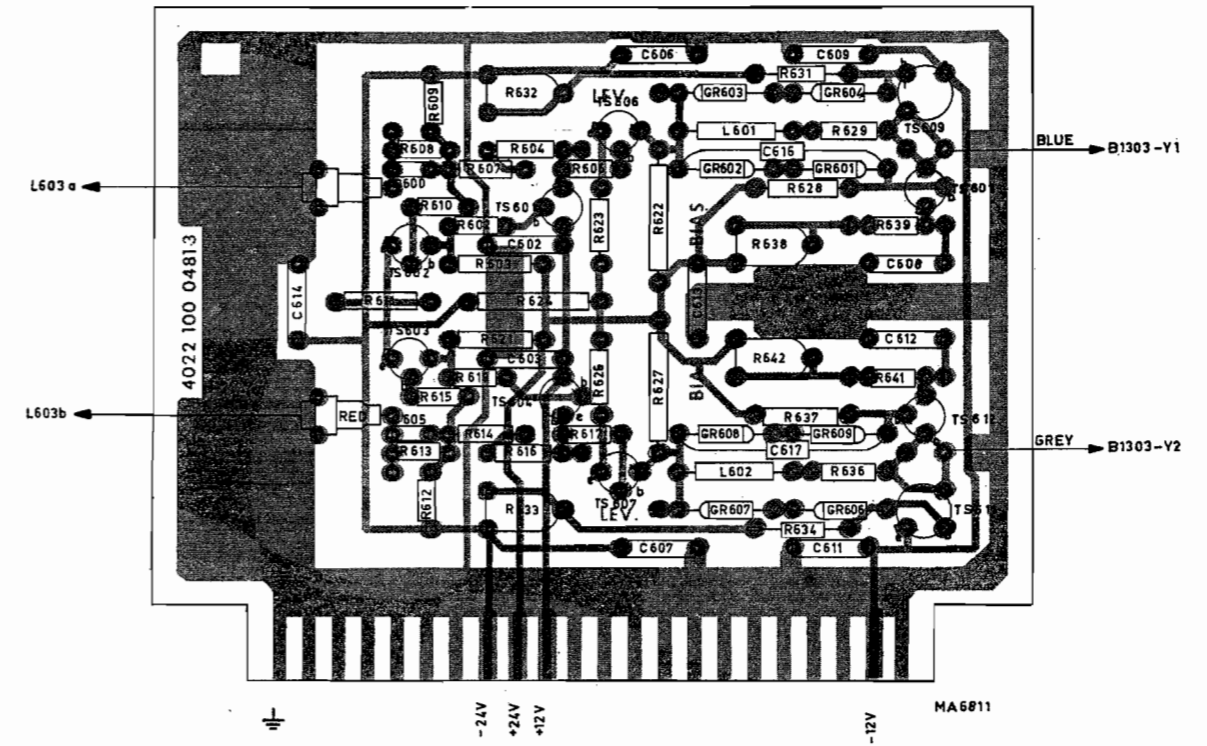

Fig. XIV-14a. Component location

Vertical output amplifier U24

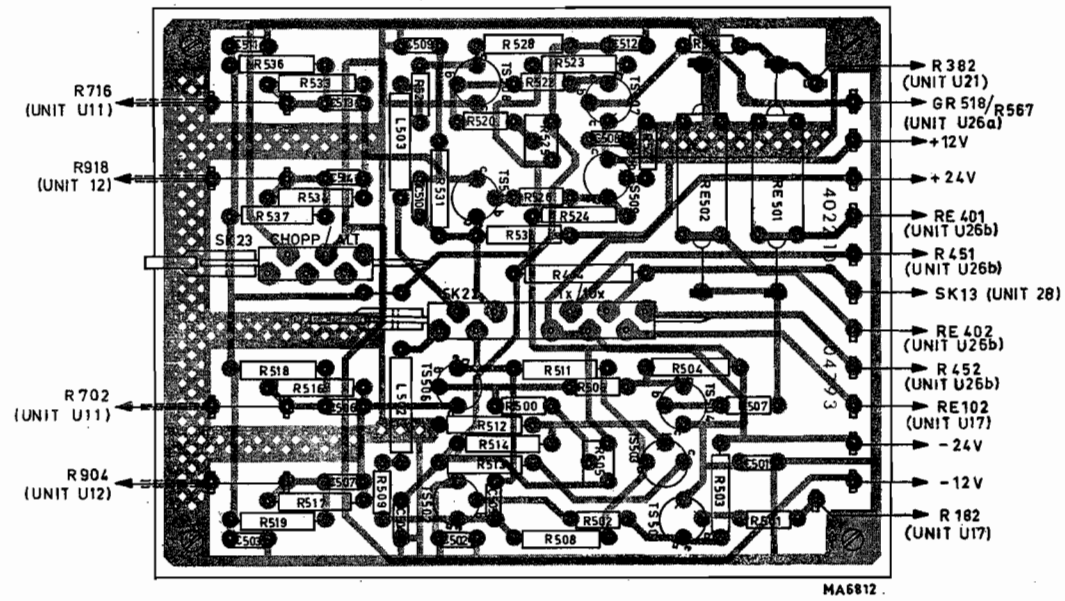

Fig. XIV-15a. Component location

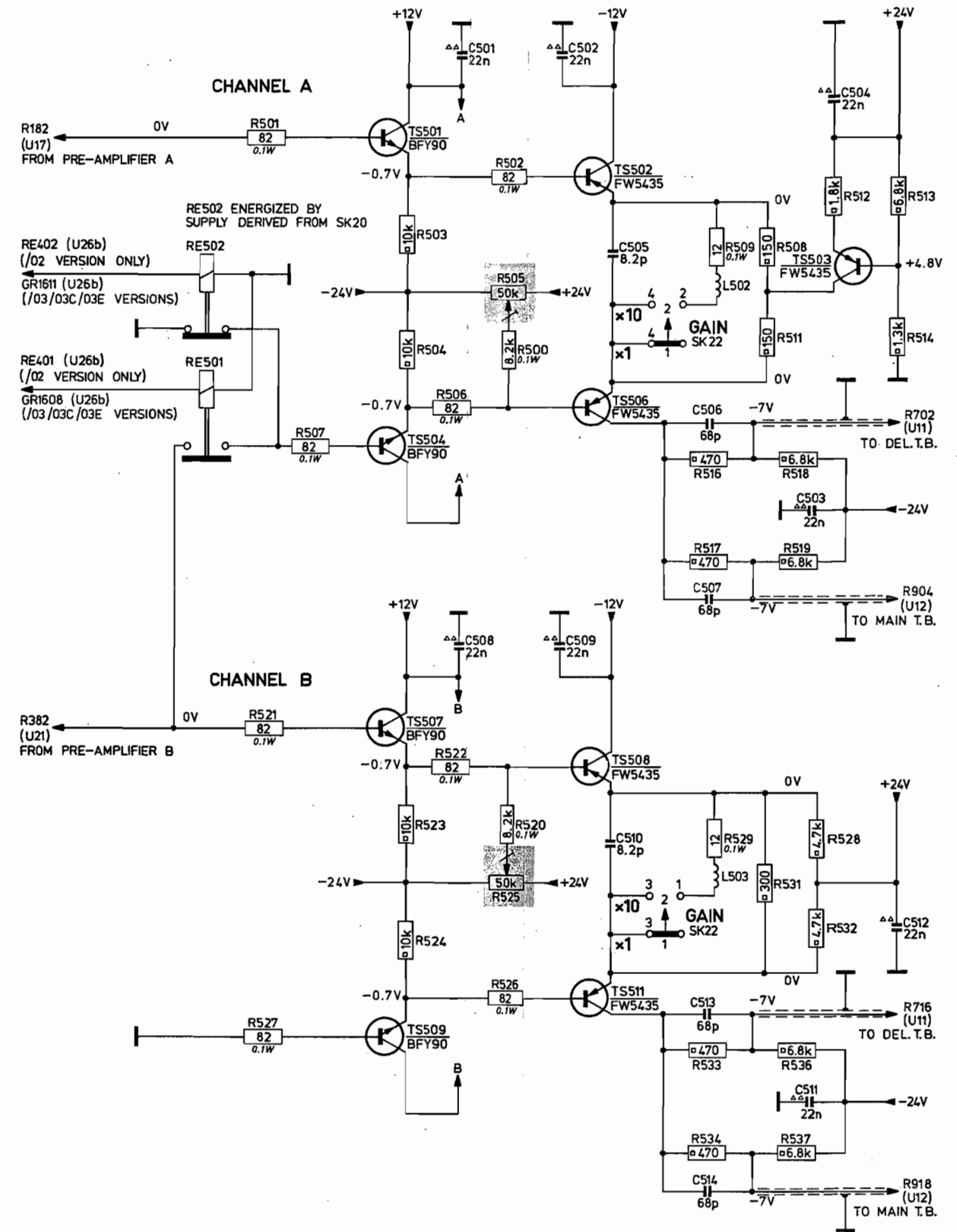

Fig. XIV-15. Circuit diagram

Trigger pick-off stage U25

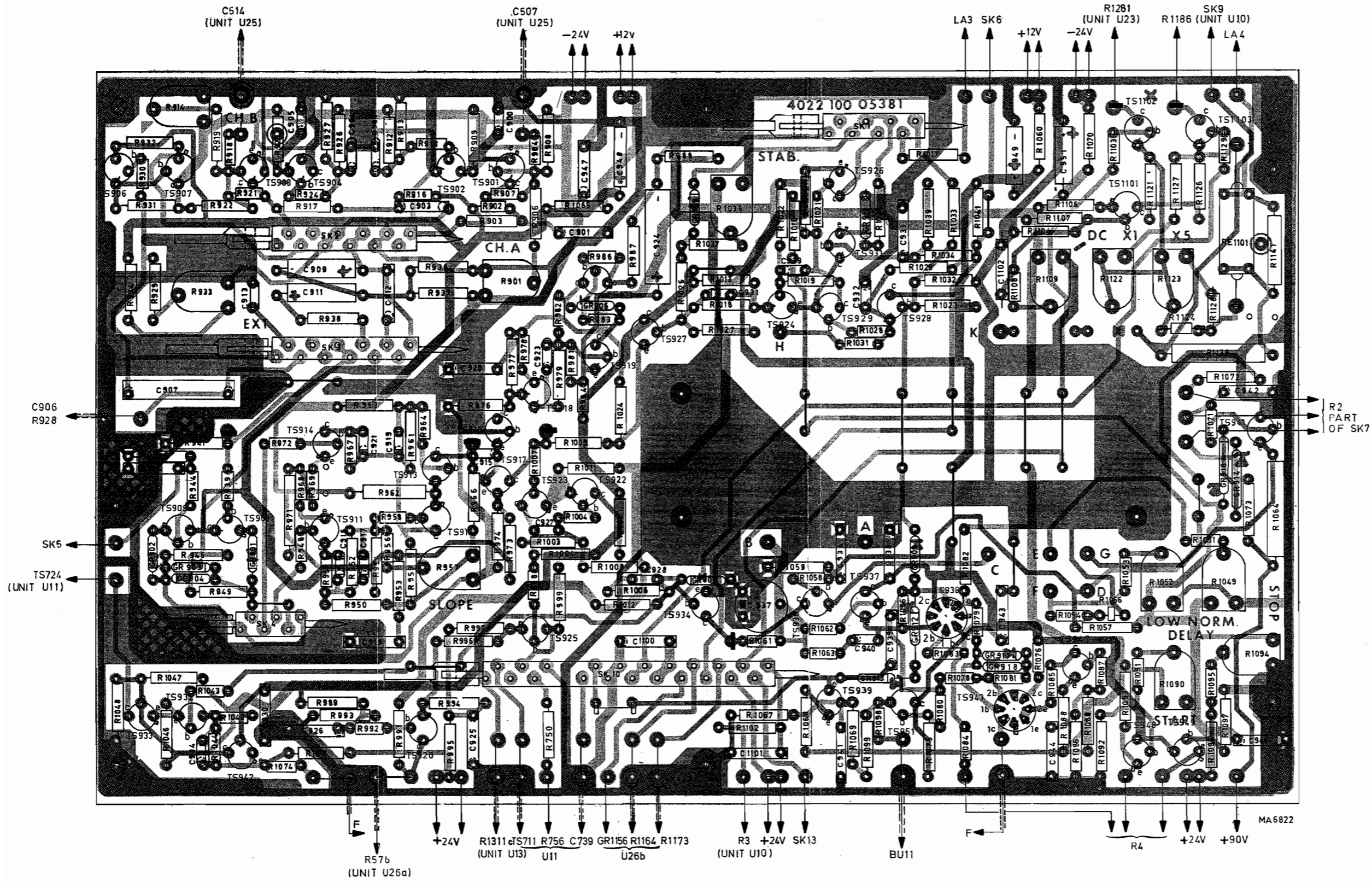

Fig. XIV-16b. Component location

Main time-base U12

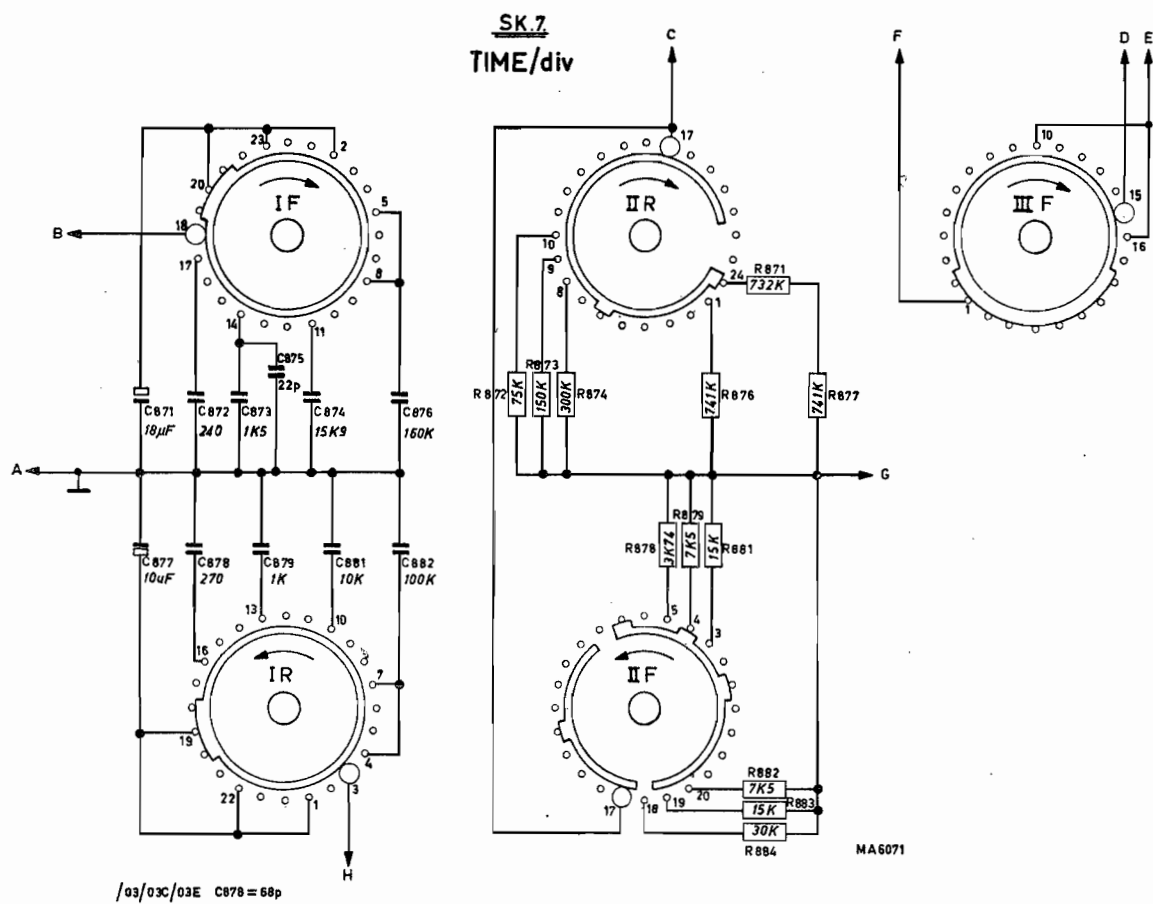
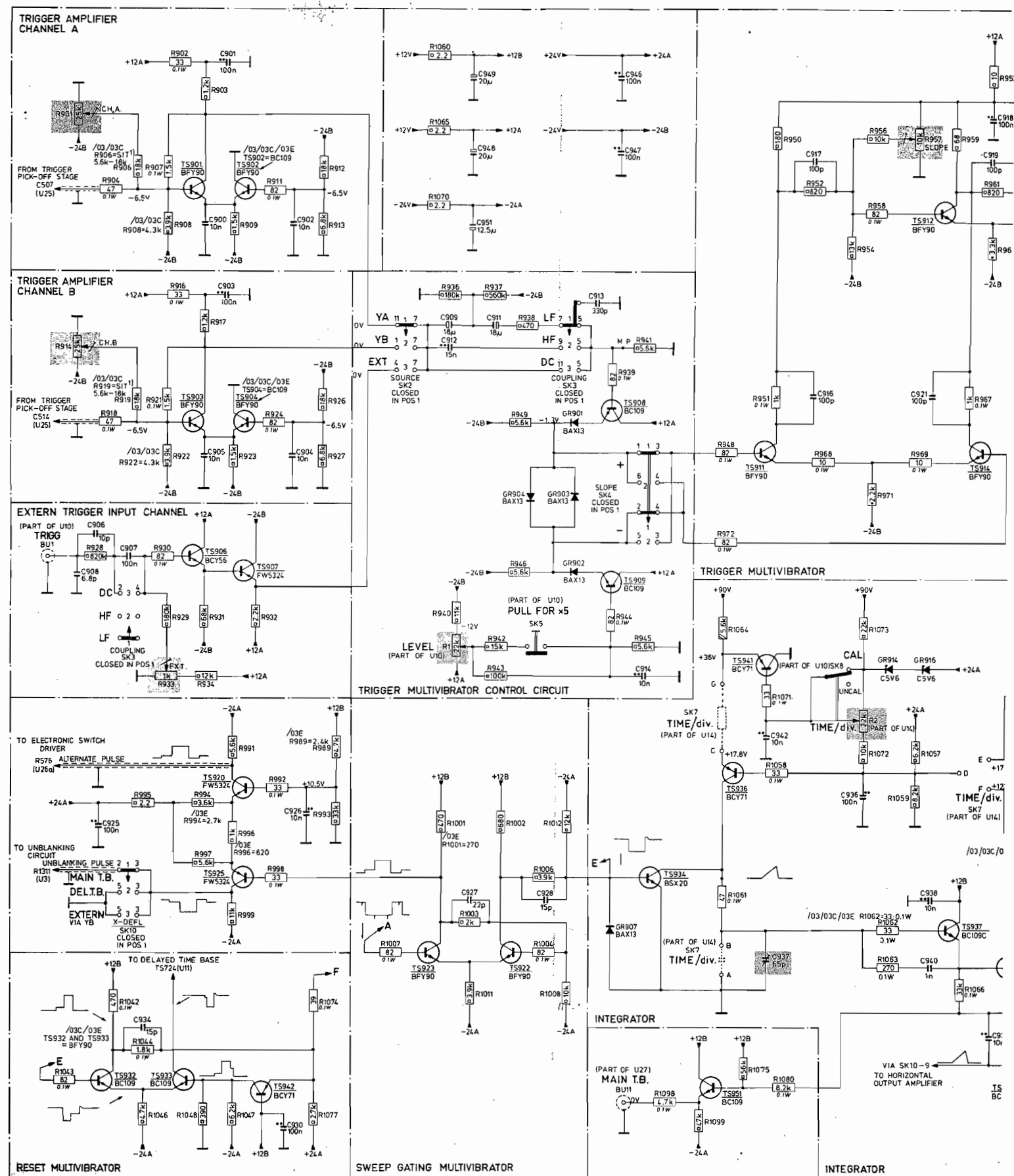

Fig. XIV-16a. Switch SK7



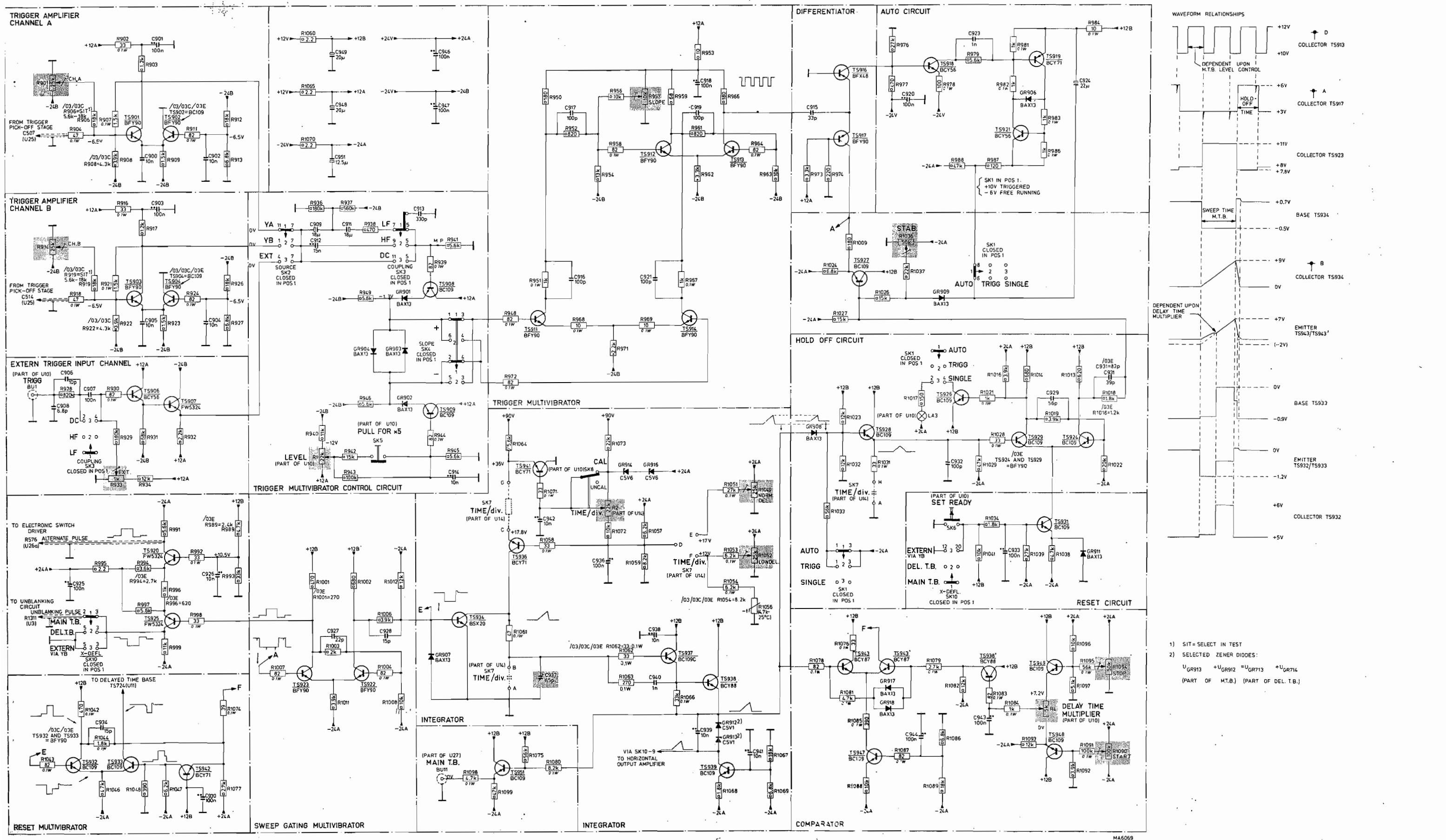

Fig. XIV-16. Circuit diagram  
Main time-base U12



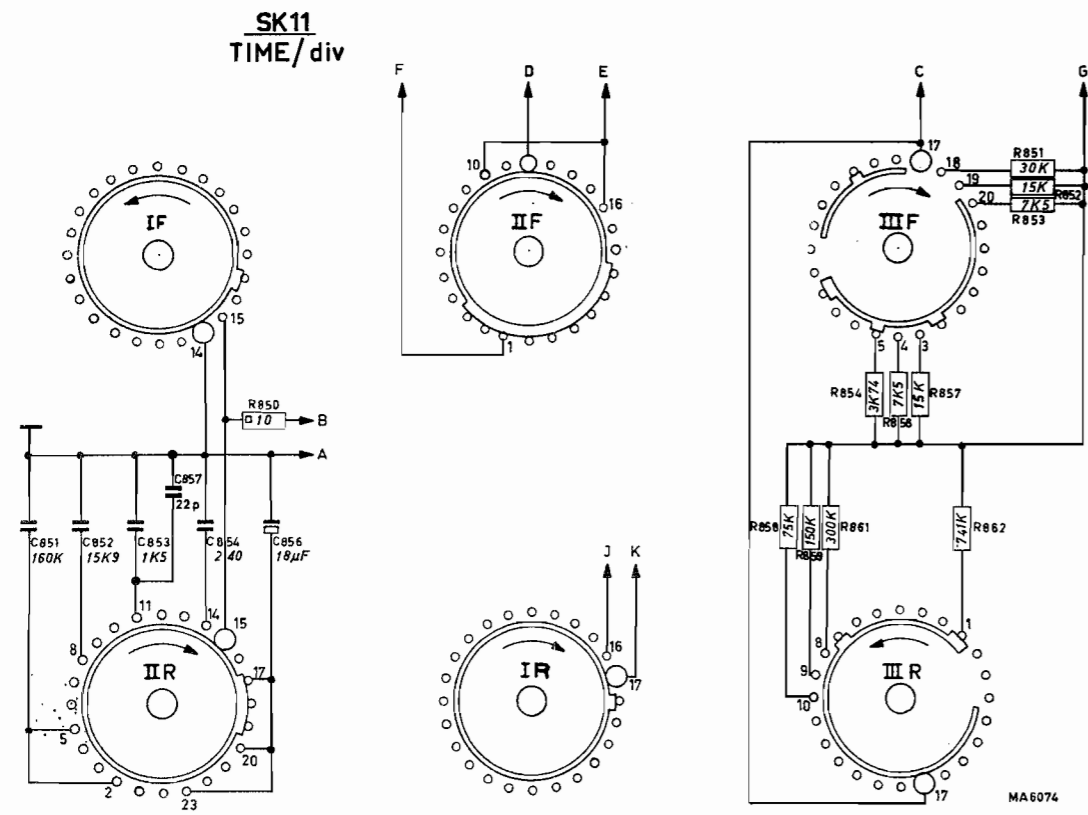

Fig. XIV-17a. Switch SK11

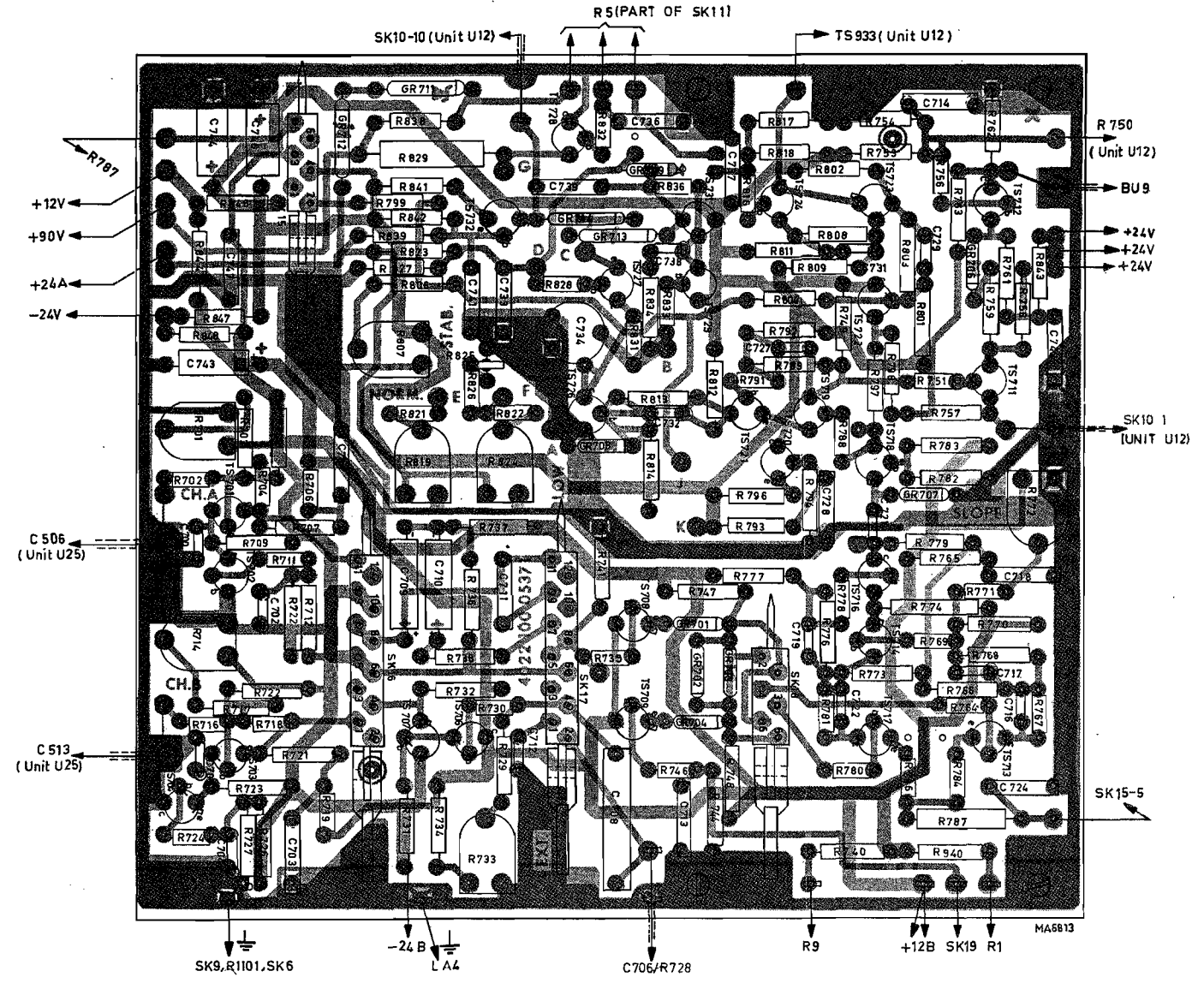

Fig. XIV-17b. Component location

Delayed time-base U11

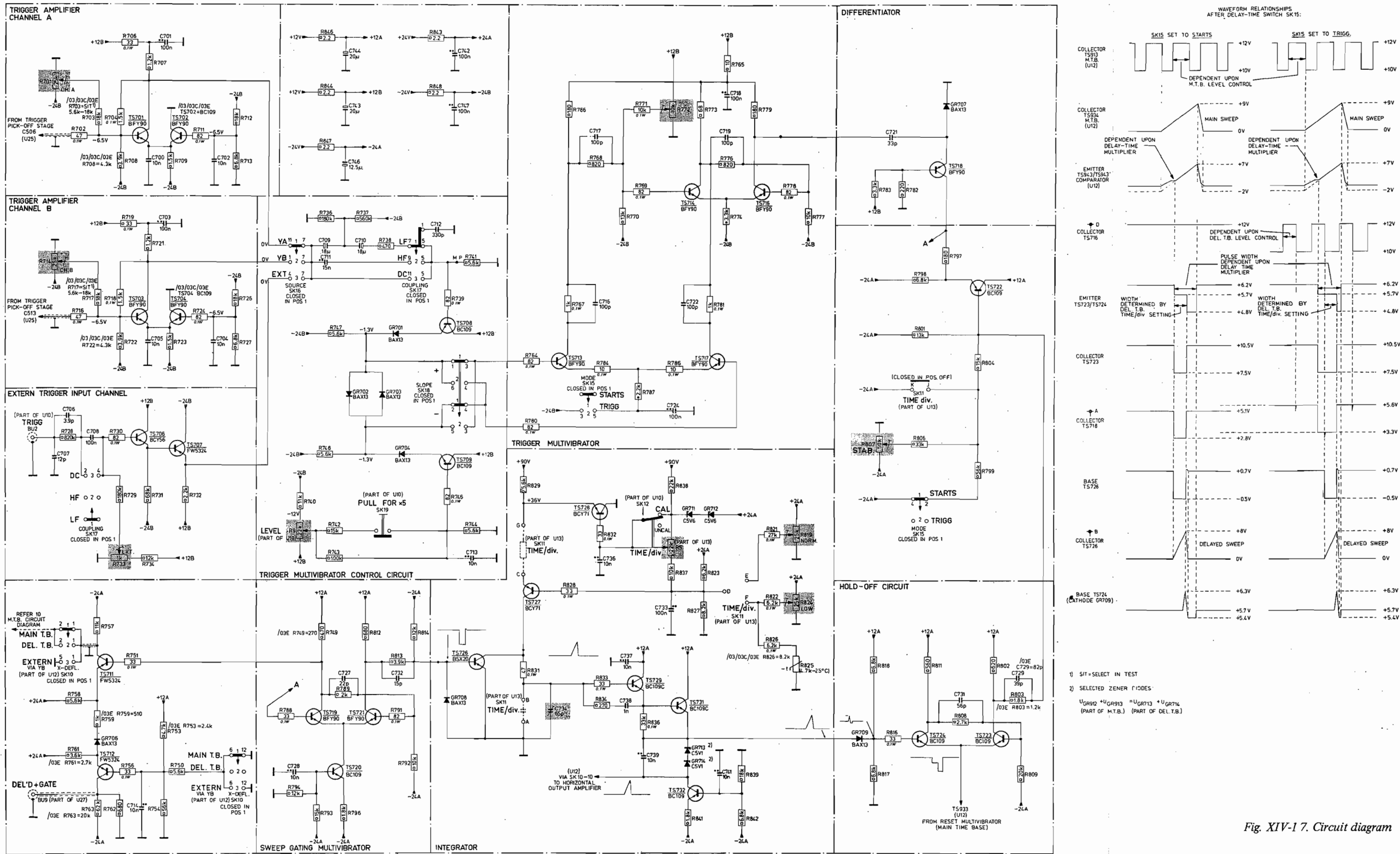

Fig. XIV-17. Circuit diagram

Delayed time-base U11

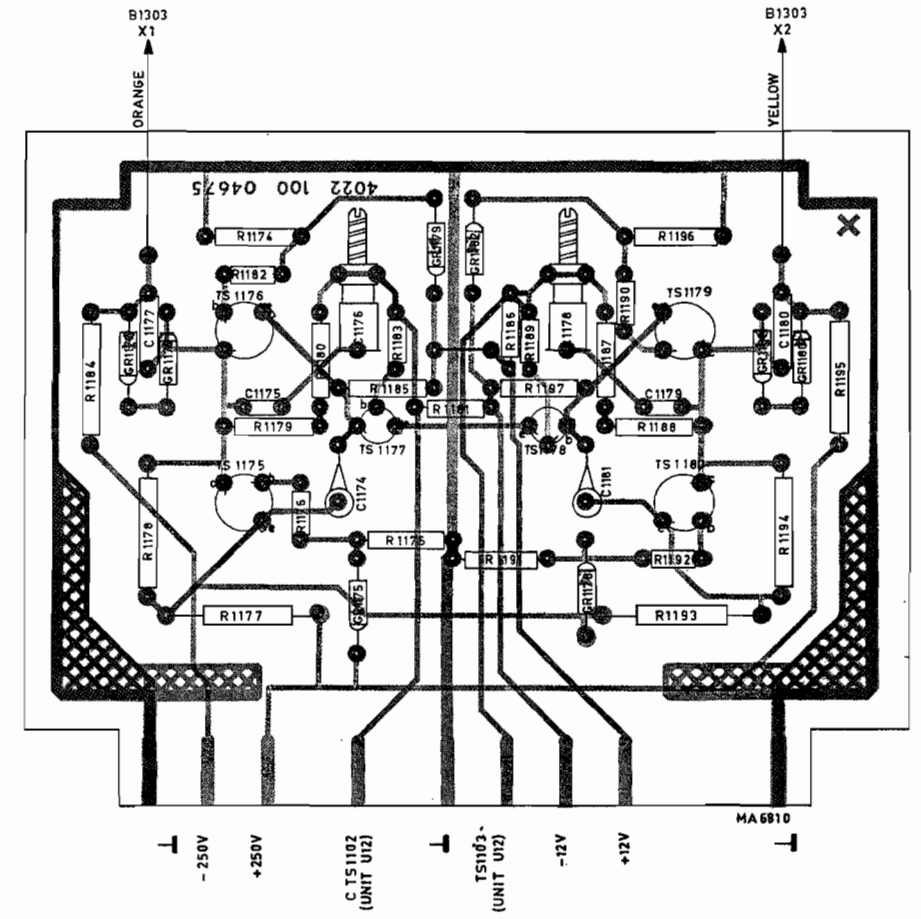
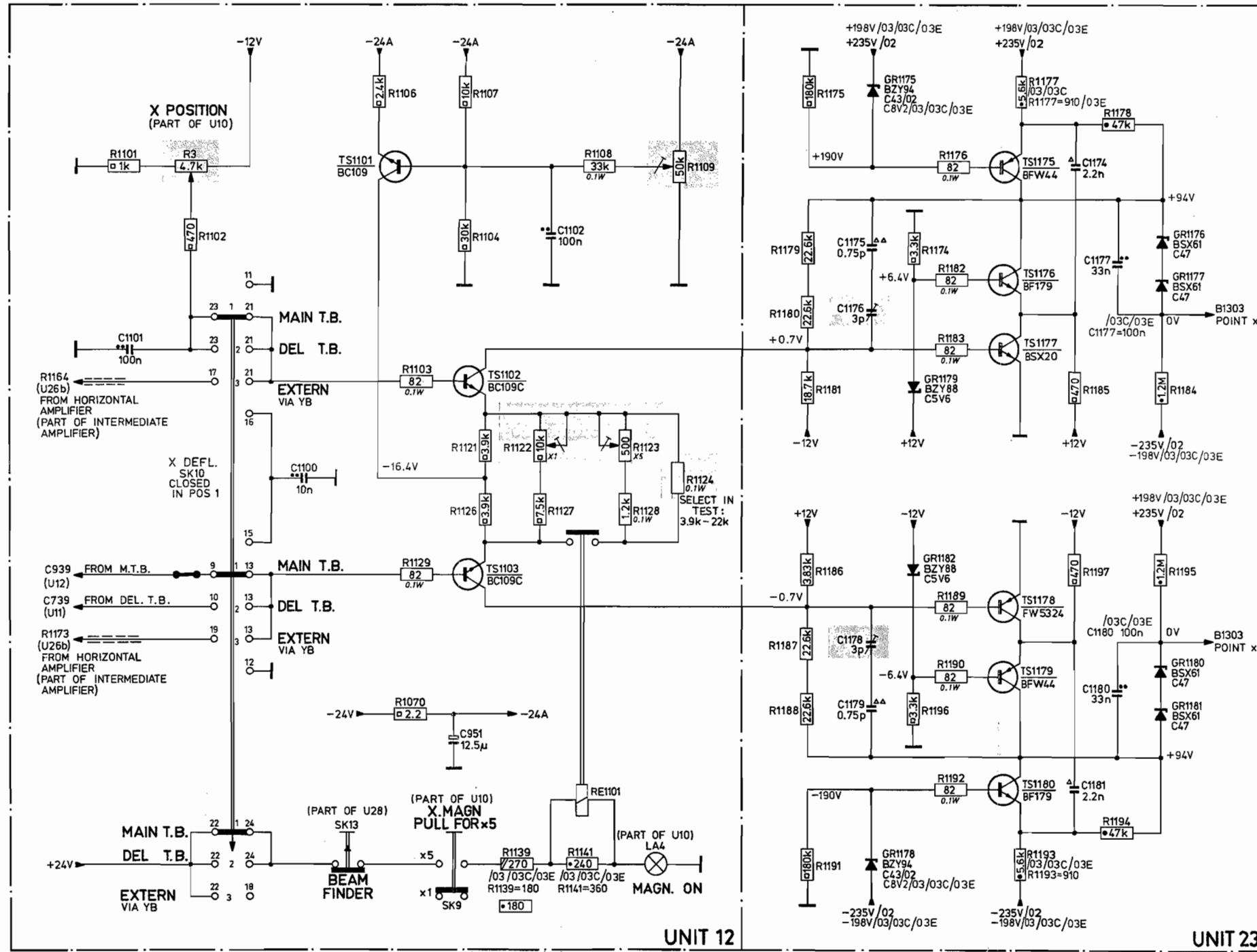

Fig. XIV-18a. Component location

Fig. XIV-18. Circuit diagram

MA6075

Horizontal output amplifier U23

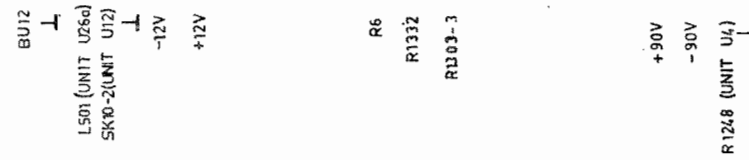
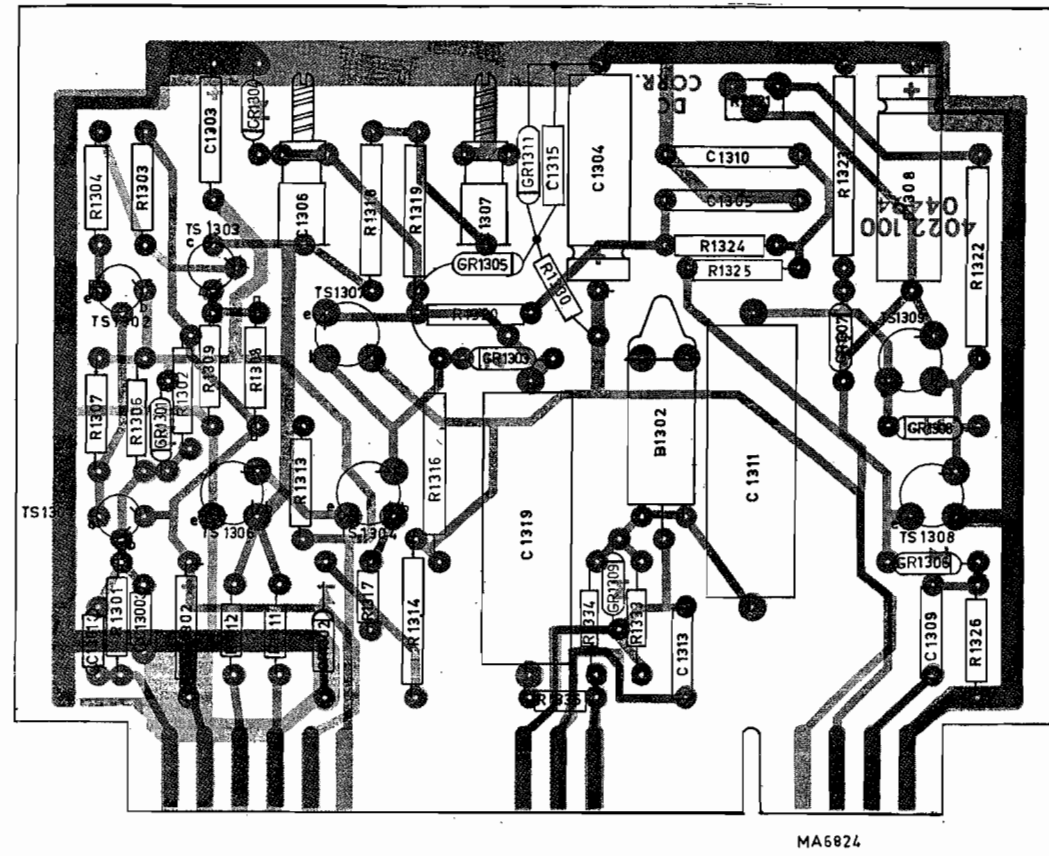
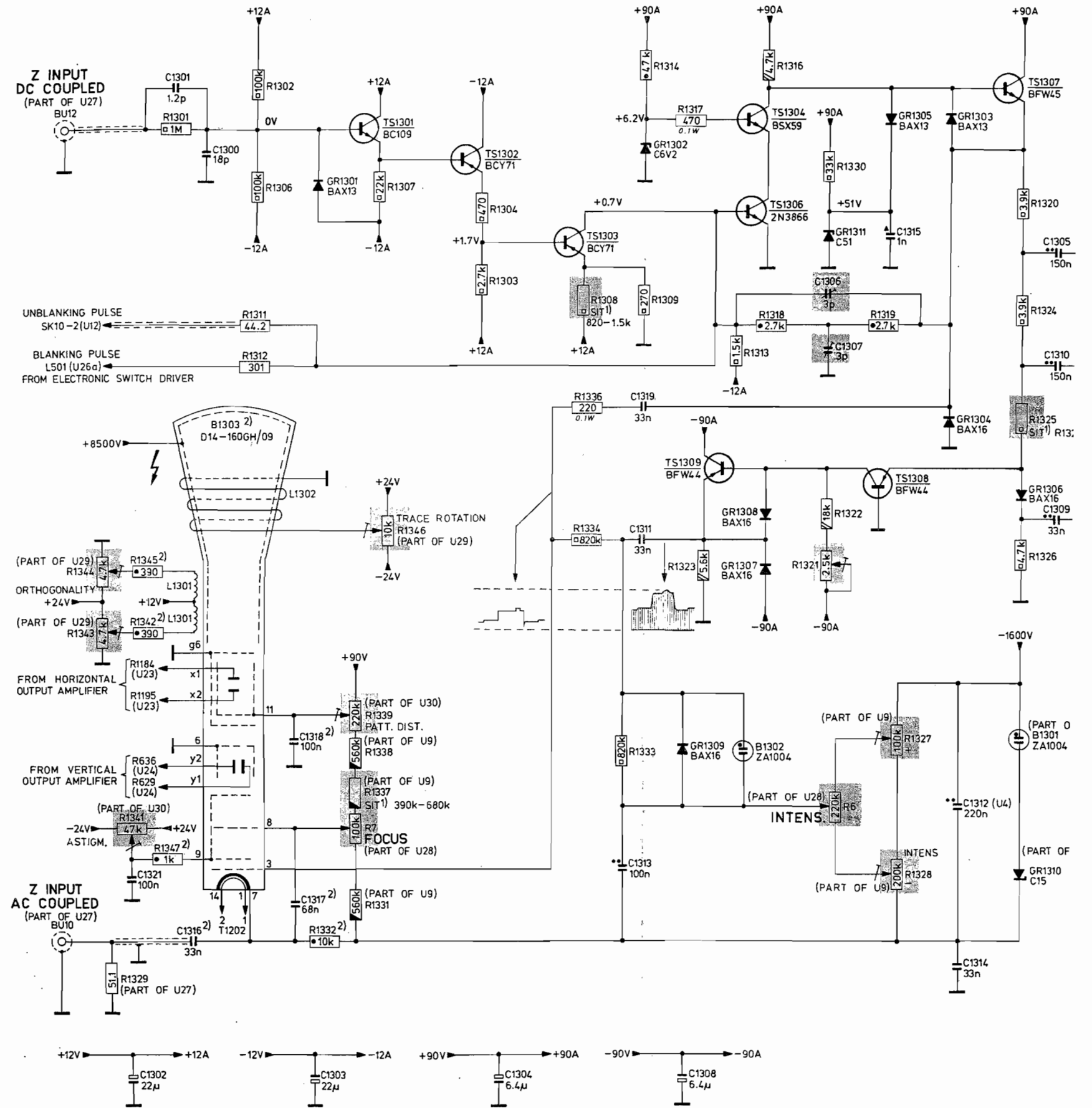
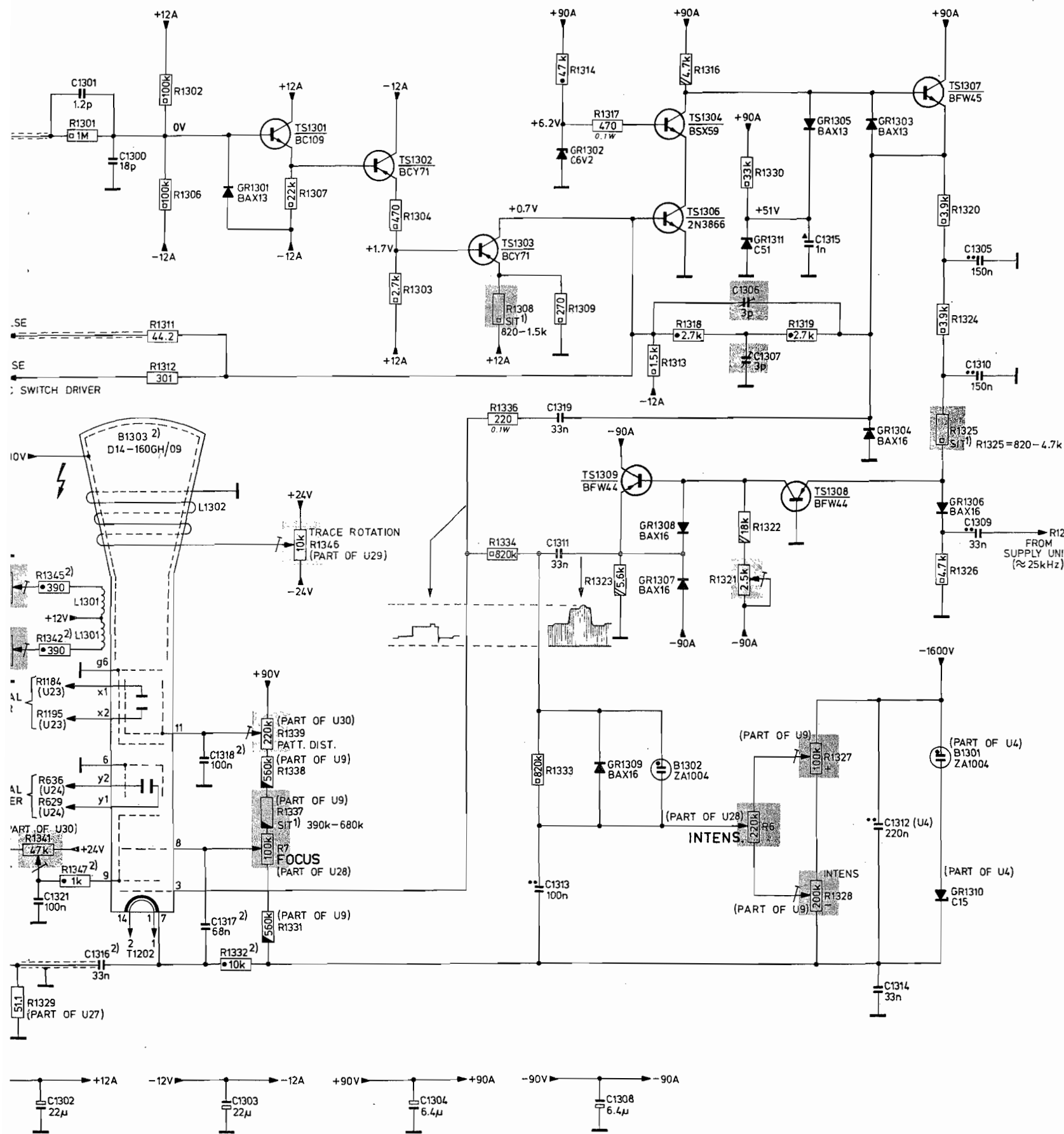
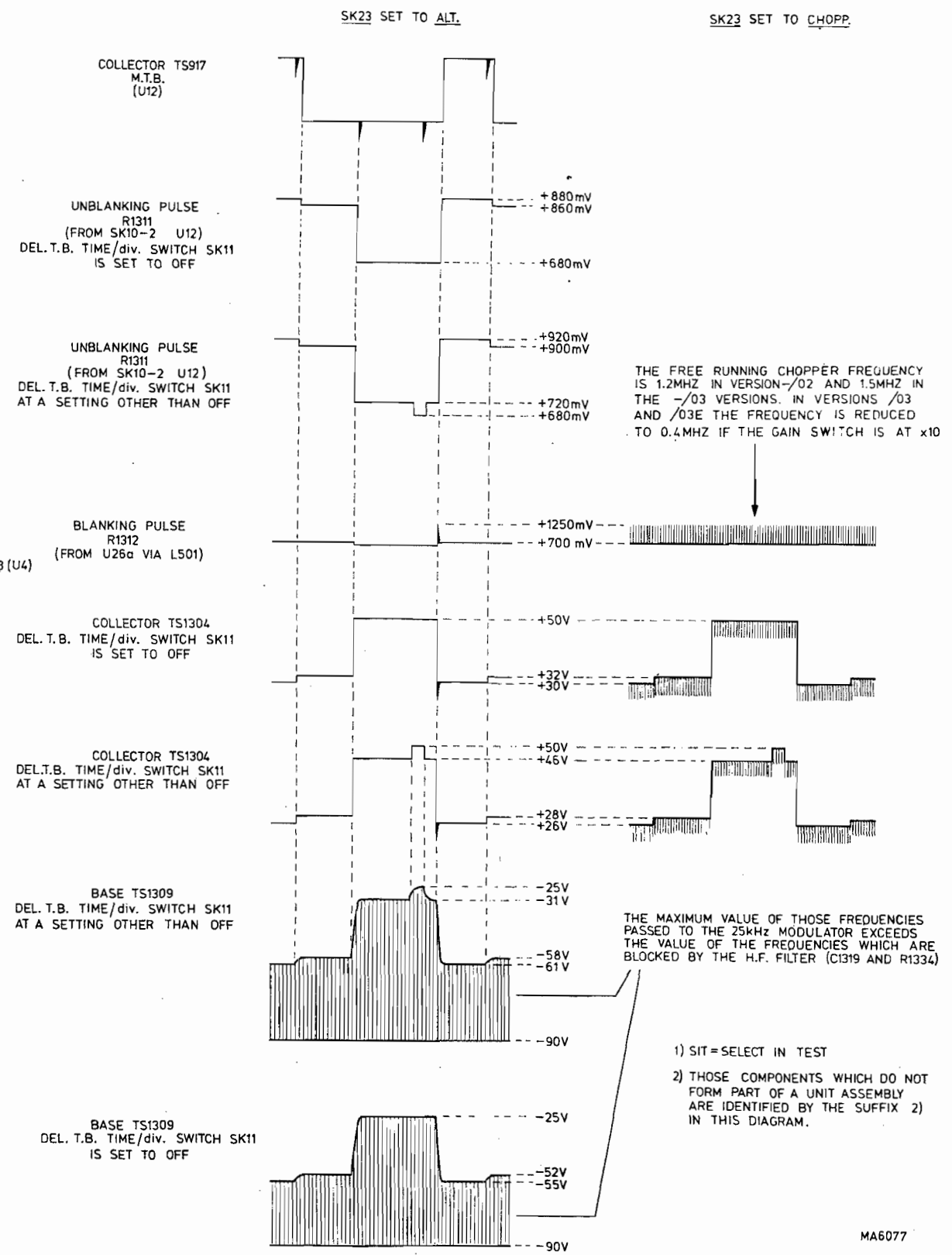

Fig. XIV-19a. Component location





WAVEFORM RELATIONSHIPS  
ALT.- CHOPP. SWITCH SK23:



MA6077

Fig. XIV-19. Circuit diagram

Unblanking (U3) and c.r.t. circuit, vers. -/02/03/03C

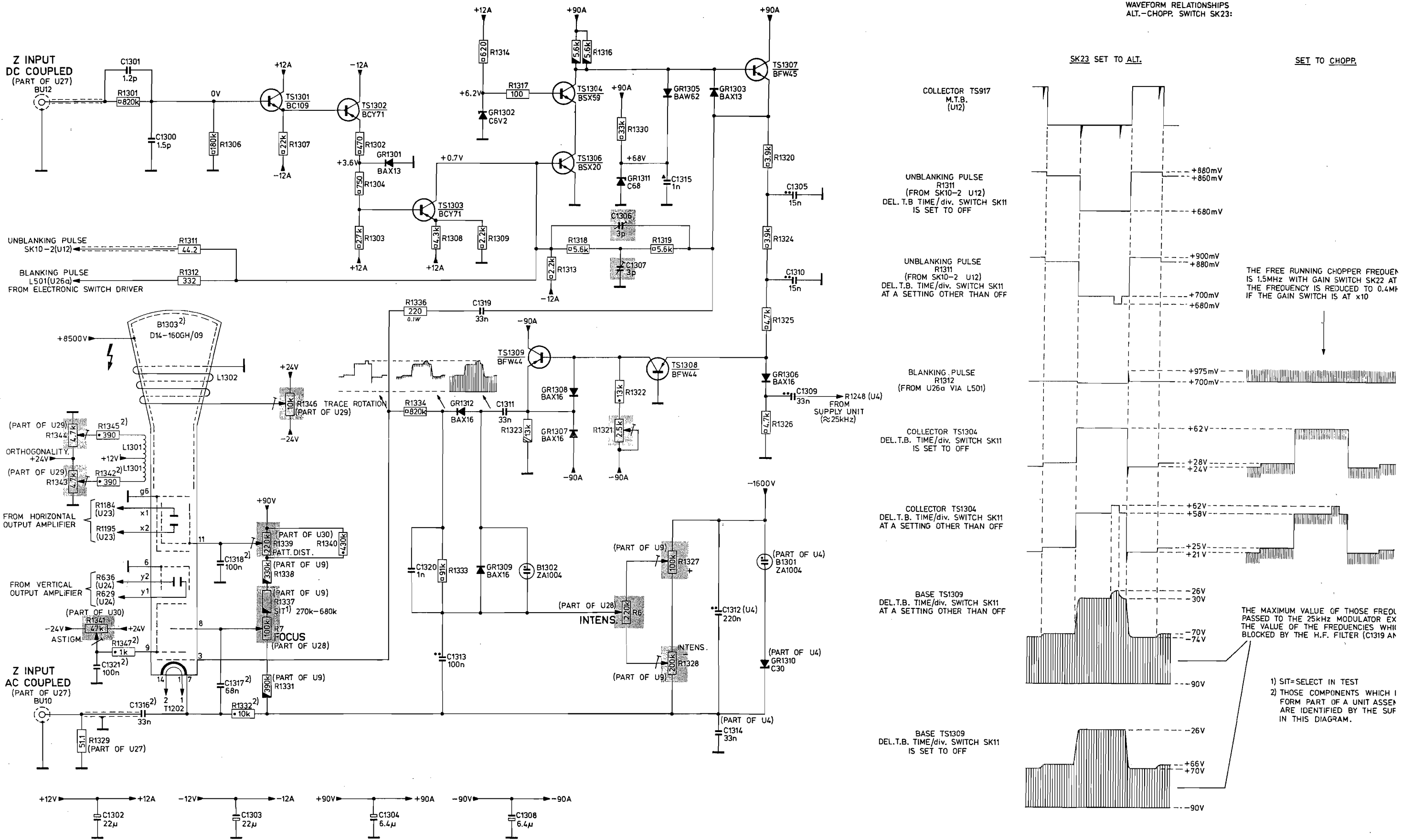

WAVEFORM RELATIONSHIPS  
ALT.-CHOPP. SWITCH SK23:

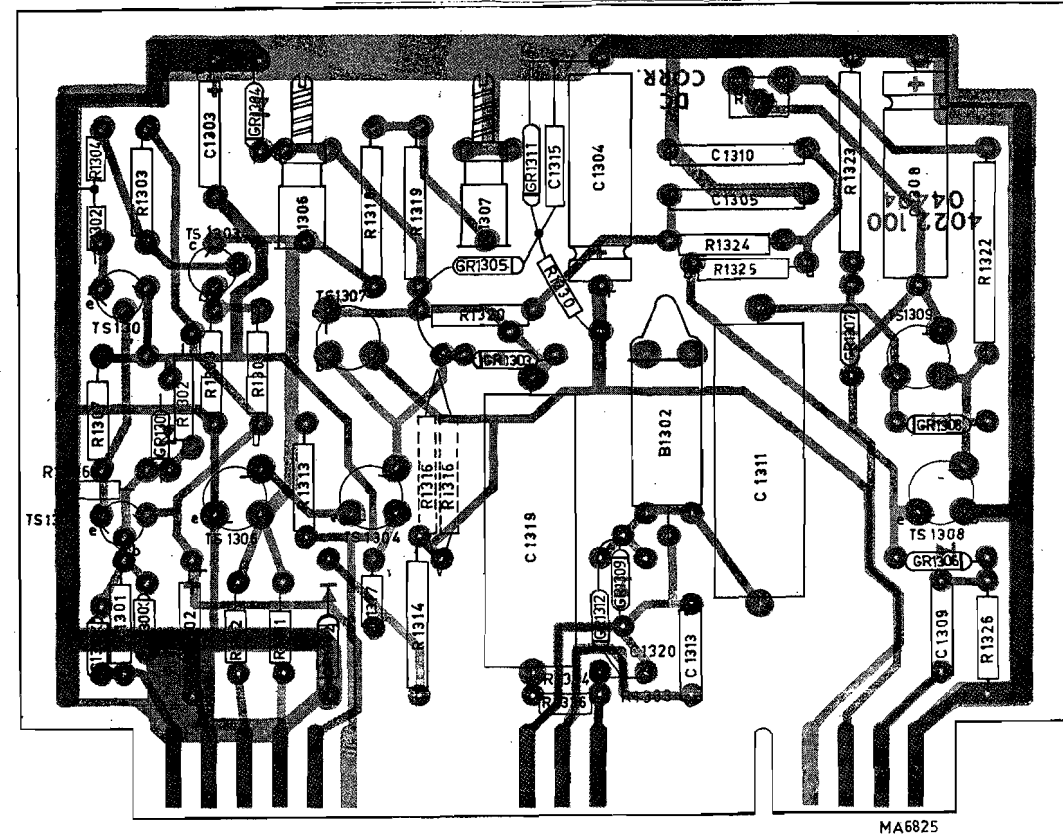
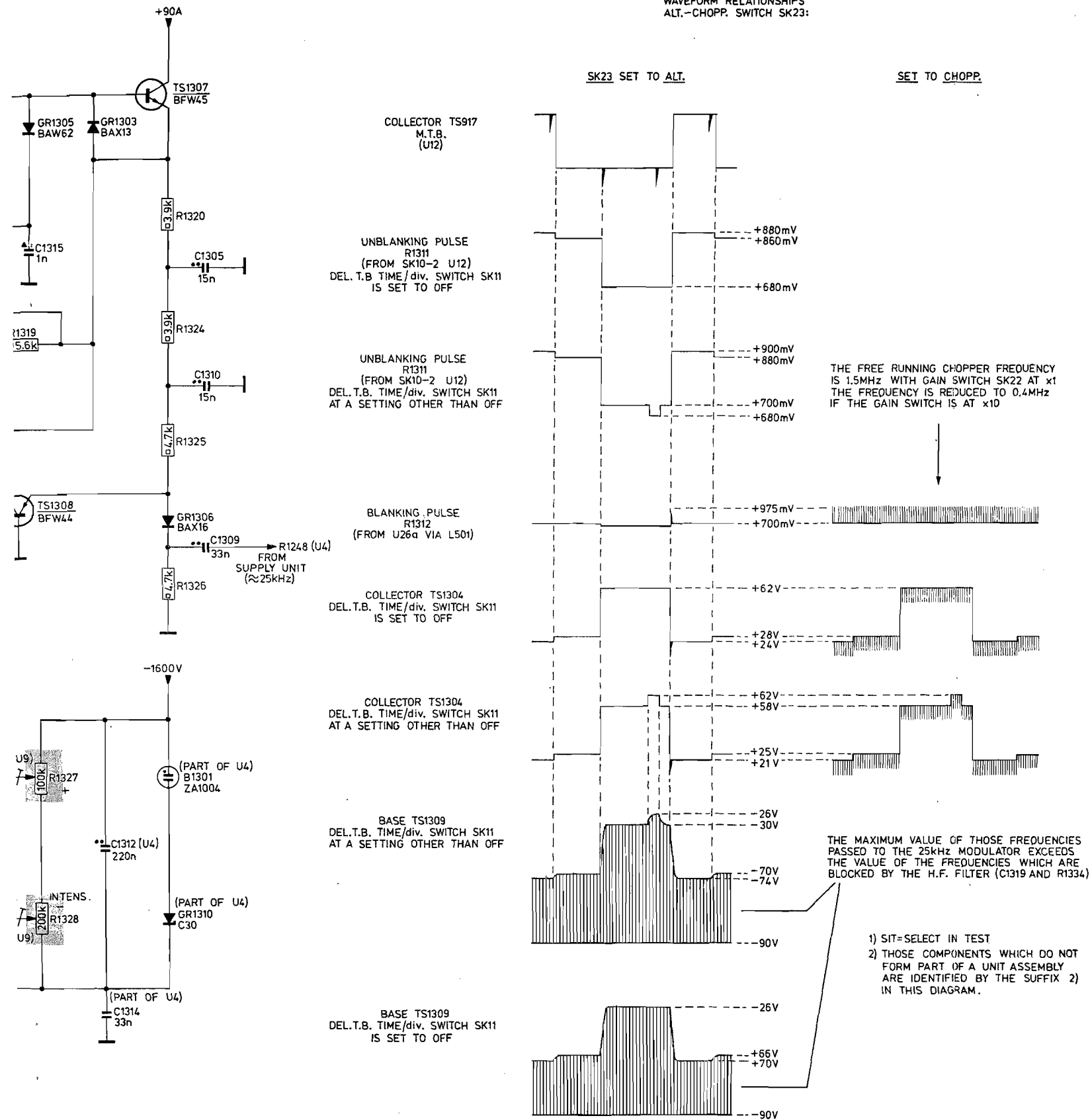

Fig. XIV-20a. Component location



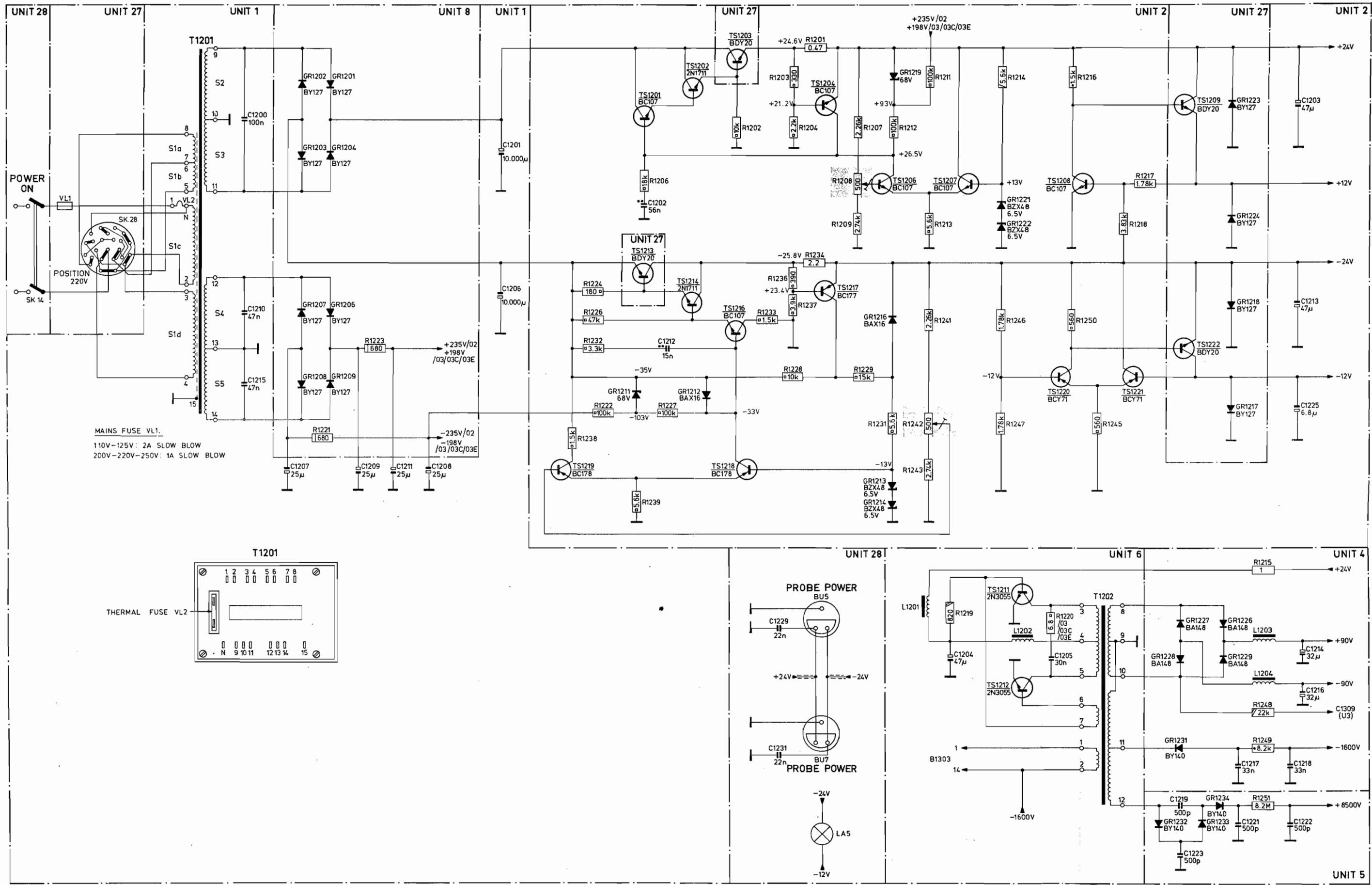

Fig. XIV-21. Circuit diagram

Power supply

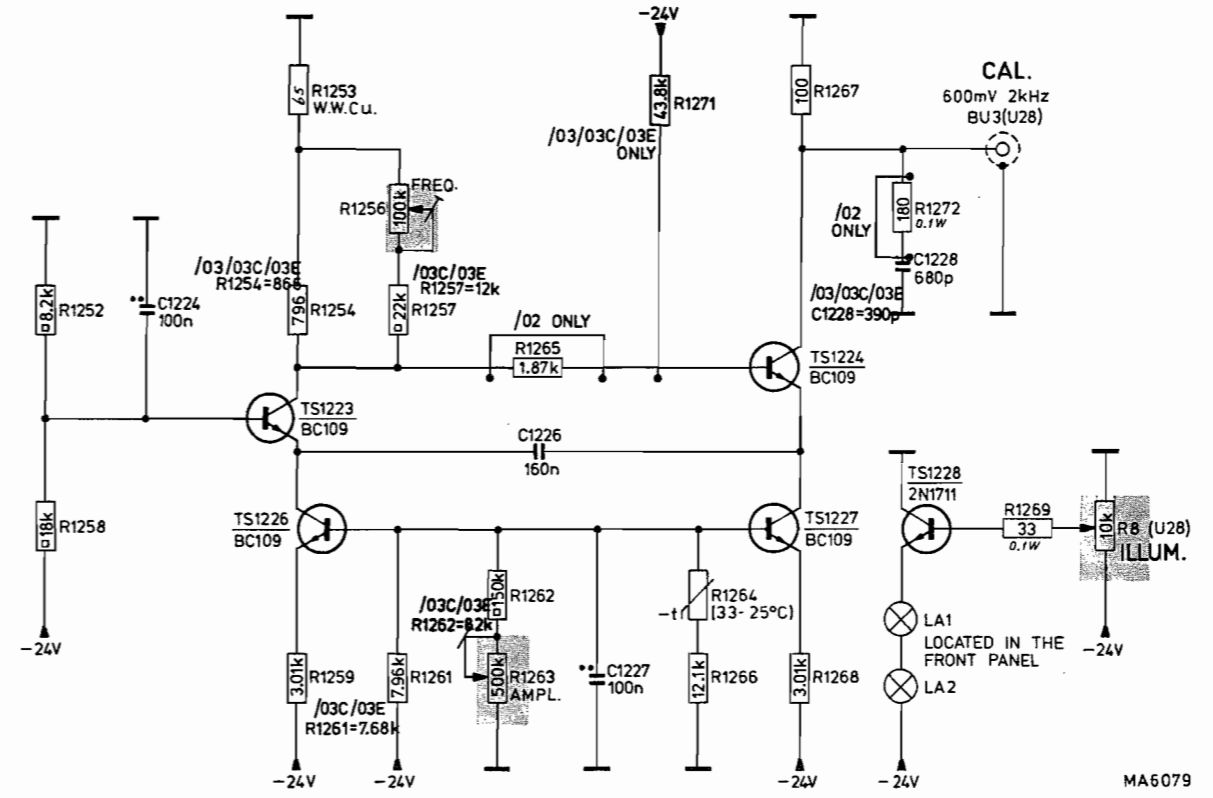

Fig. XIV-22. Circuit diagram

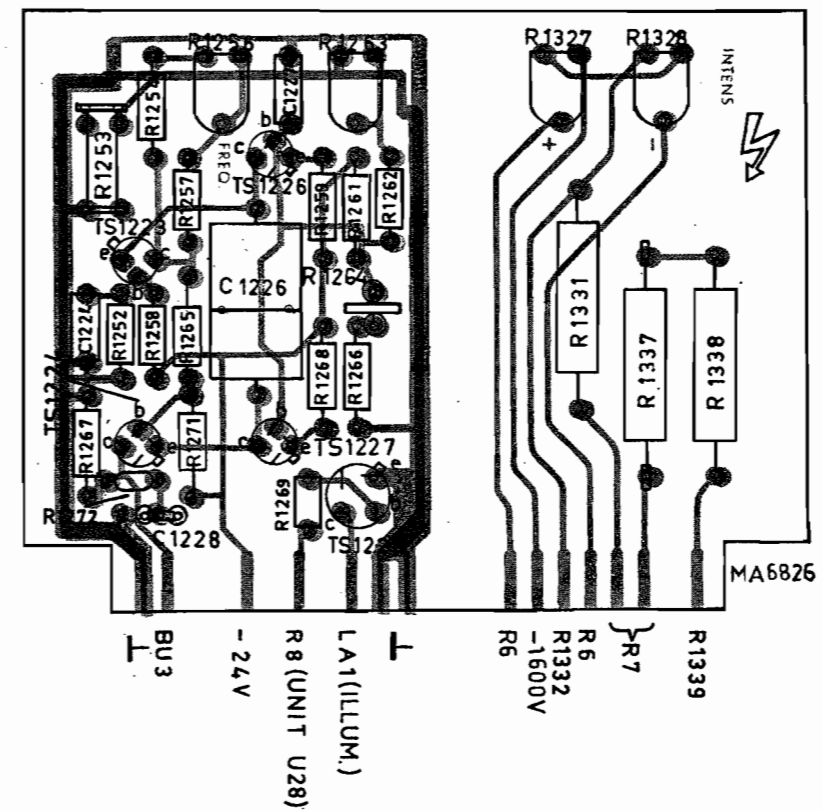
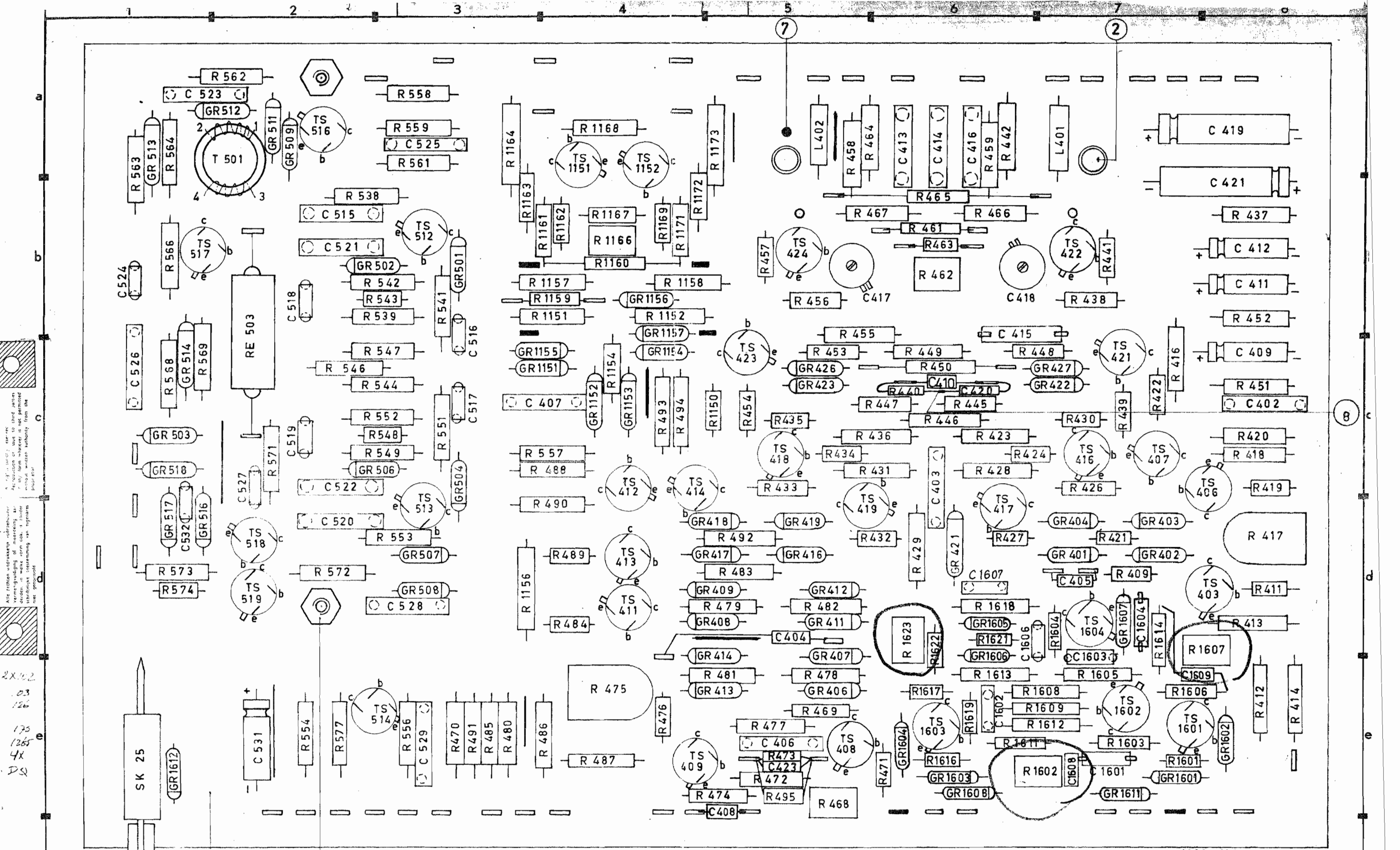

Fig. XIV-22a. Component location

Calibration unit U9



Alle rechten voorbehouden. Het is niet toegestaan de afbeeldingen of de inhoud van dit document te kopiëren, te verspreiden of openbaar te maken. Het is niet toegestaan de afbeeldingen of de inhoud van dit document te kopiëren, te verspreiden of openbaar te maken. Het is niet toegestaan de afbeeldingen of de inhoud van dit document te kopiëren, te verspreiden of openbaar te maken.

2X102  
 .03  
 126  
 175  
 1265  
 4X  
 DS

4022 100 47470

UNIT 26 PM 3250		4022 100 4748	
TUSSENVERSTERKER.			
NAME v. GERVEN.	SUPERS. VERV.	1 SH.	SH. 110 - 1
PROPERTY OF N.V. PHILIPS' GLOEILAMPENFABRIEKEN EINDHOVEN - NEDERLAND		CHECK CONT.	DAT. 30-10-'69 FORM. A3

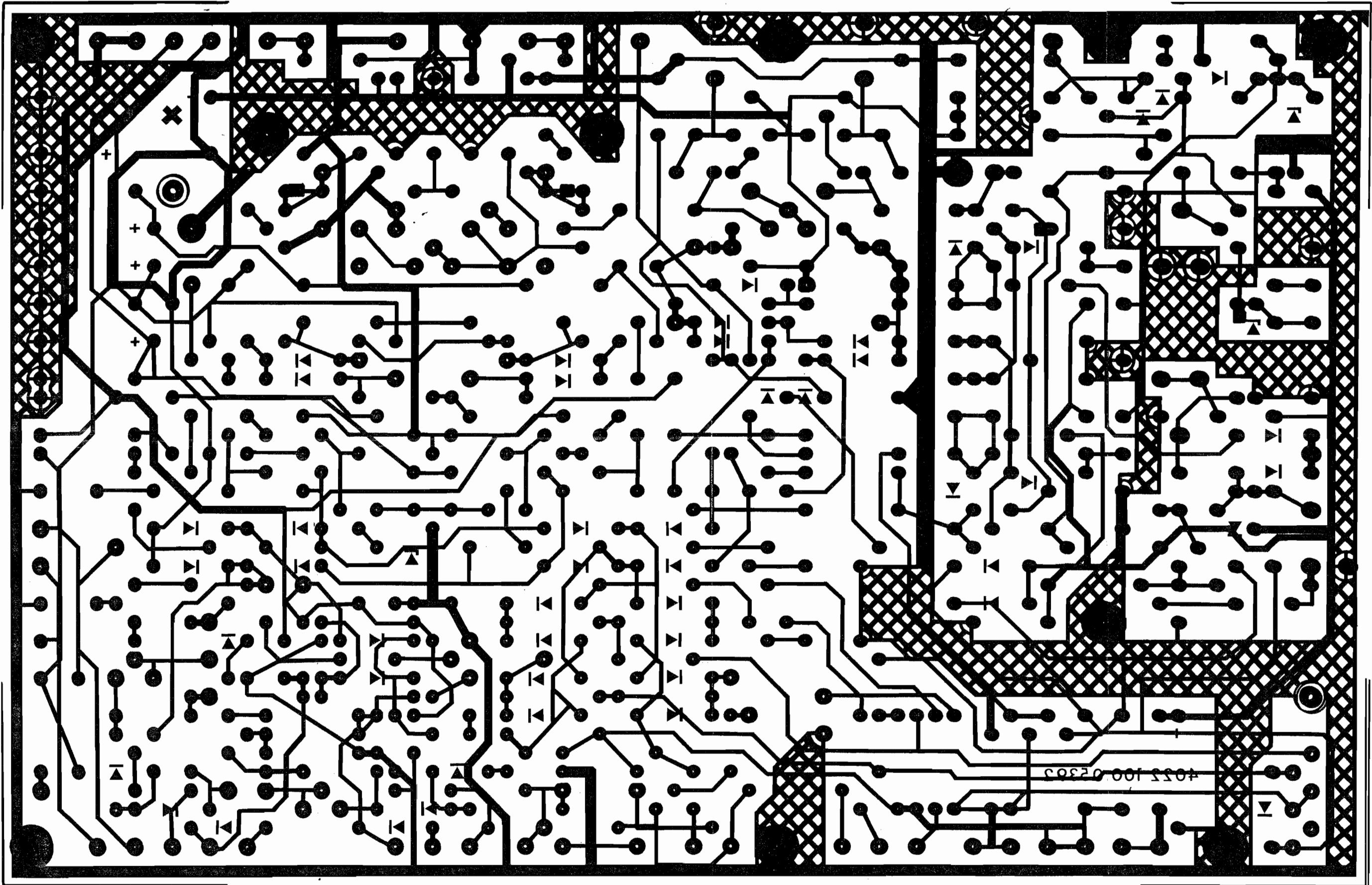

4022 100 05392

4022 100 05392

31 12 69  
31 12 69

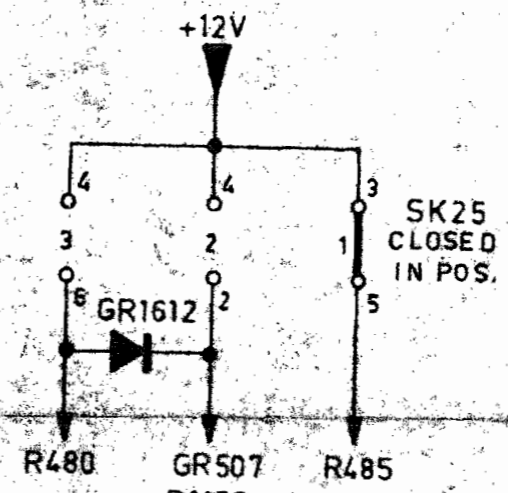
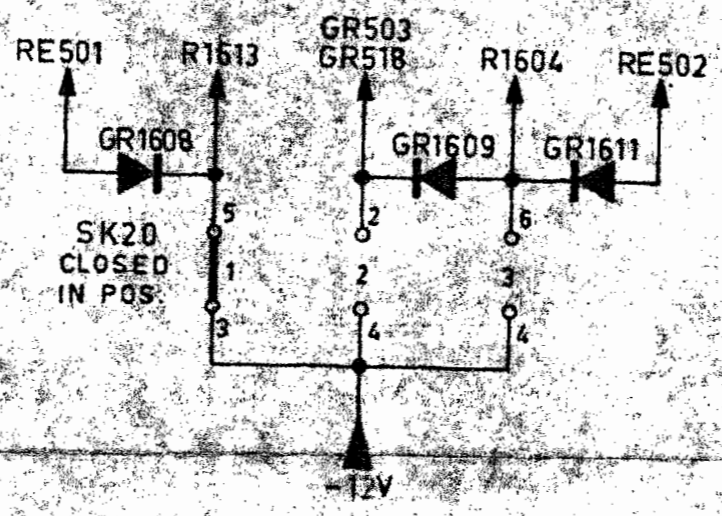
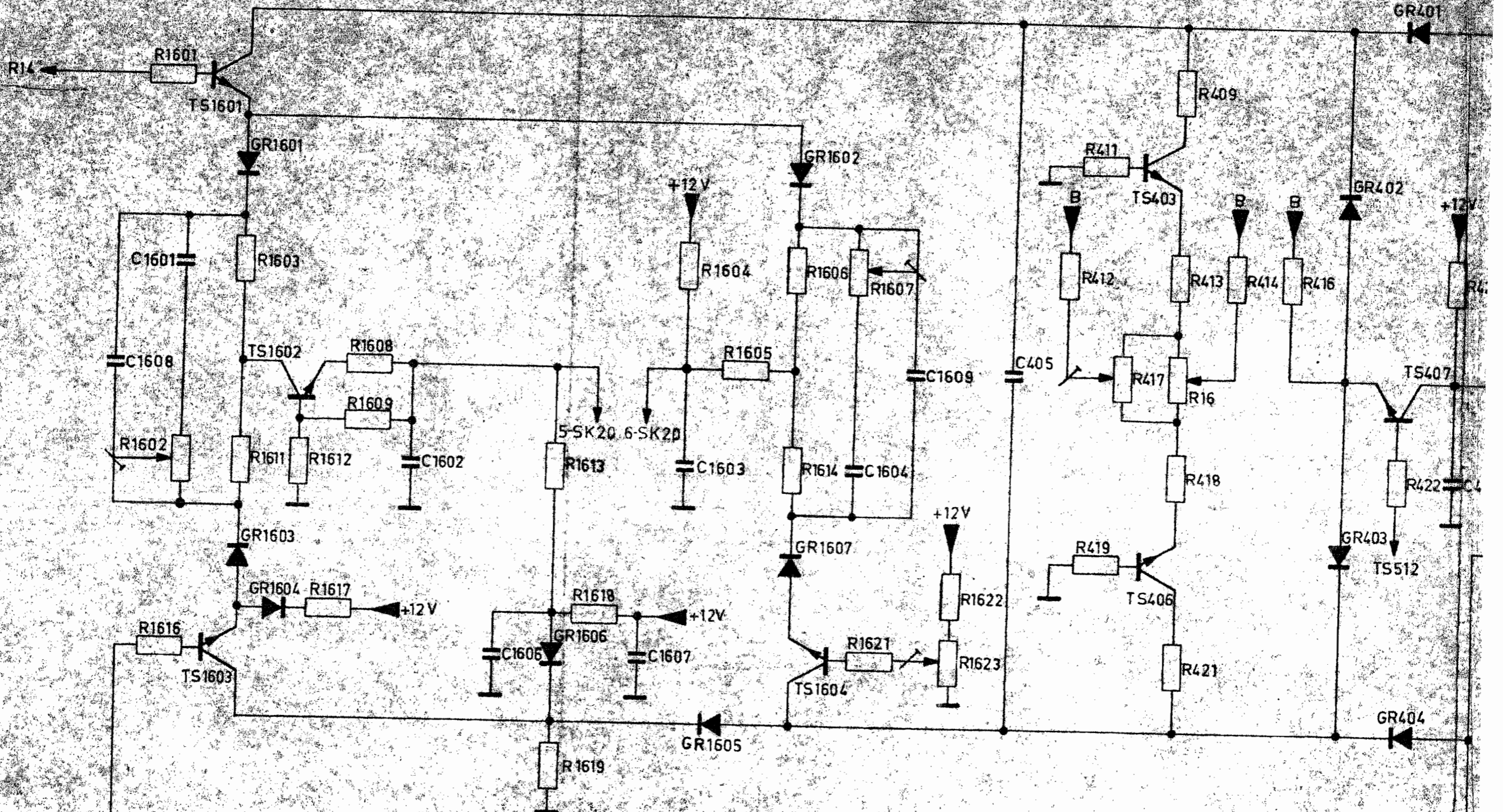

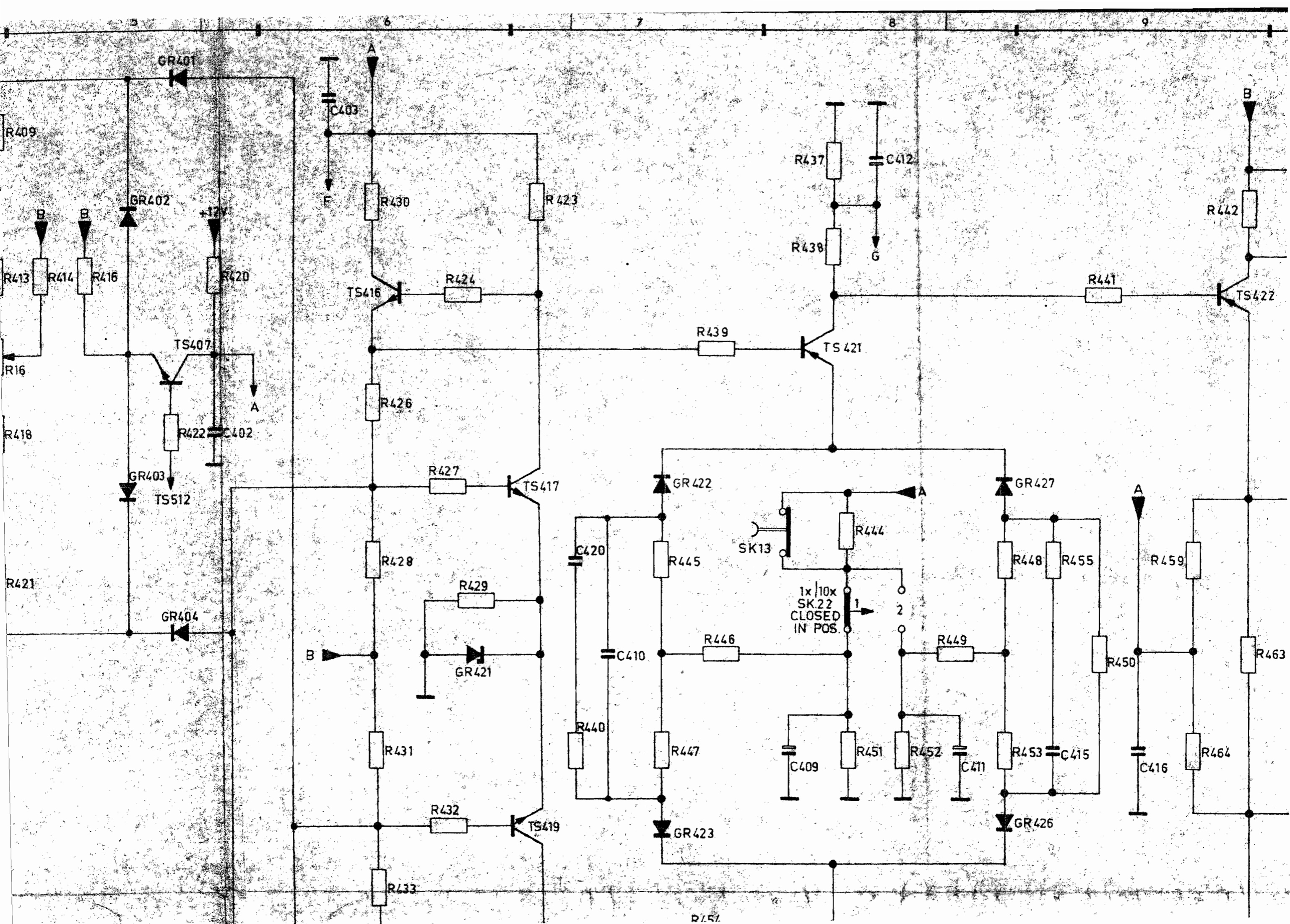

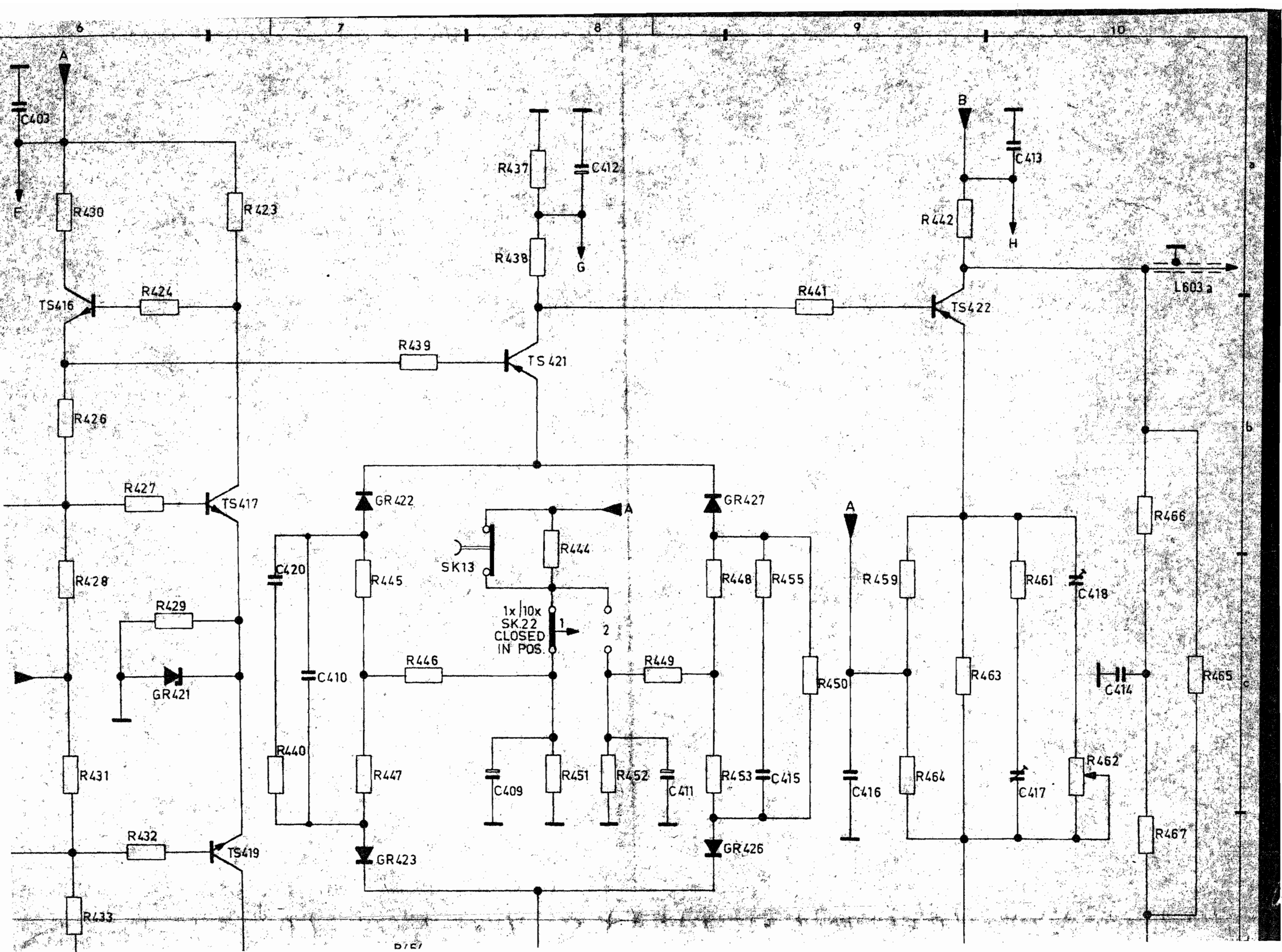

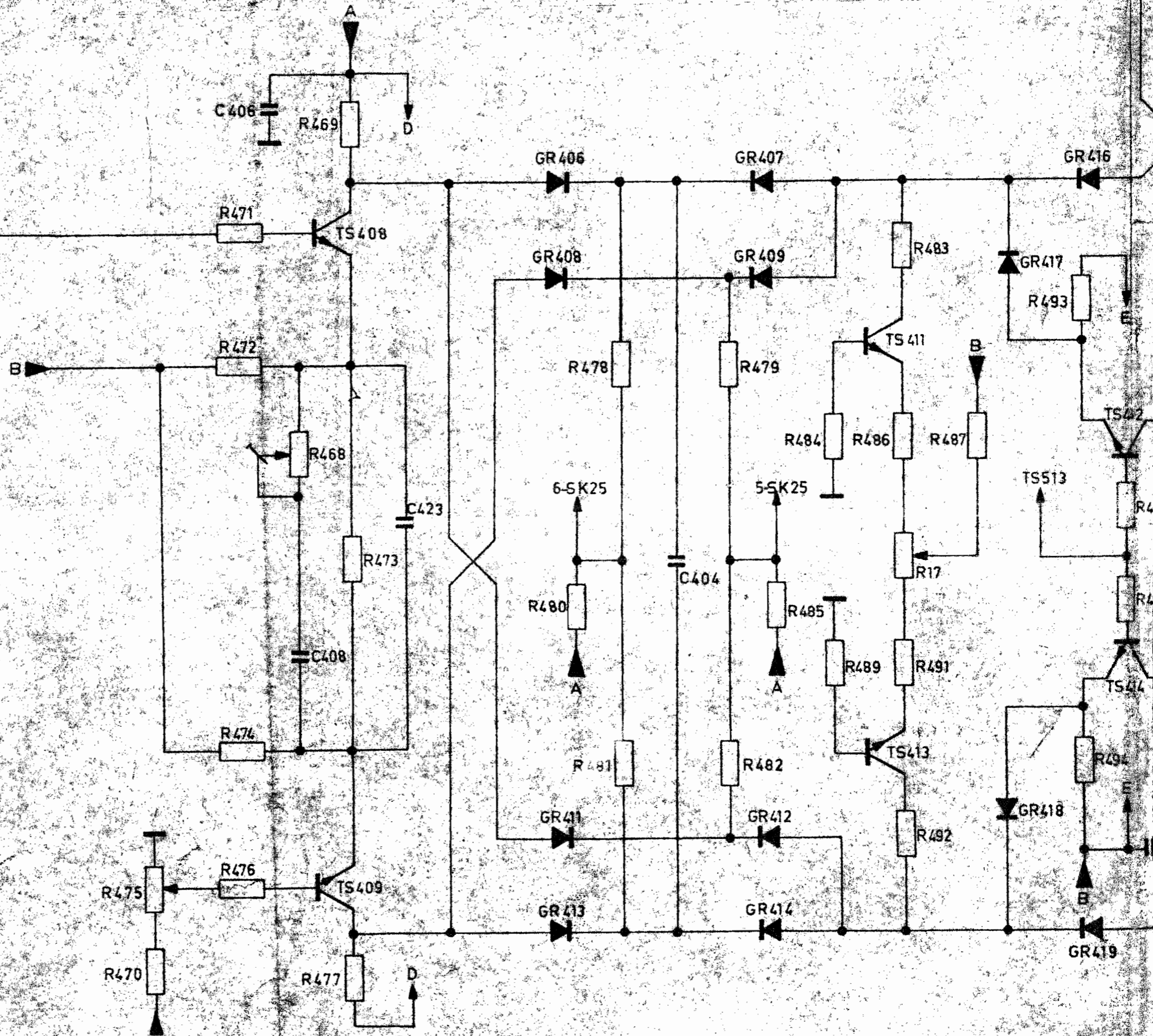

103  
111  
126  
152  
175  
214  
266  
330  
41



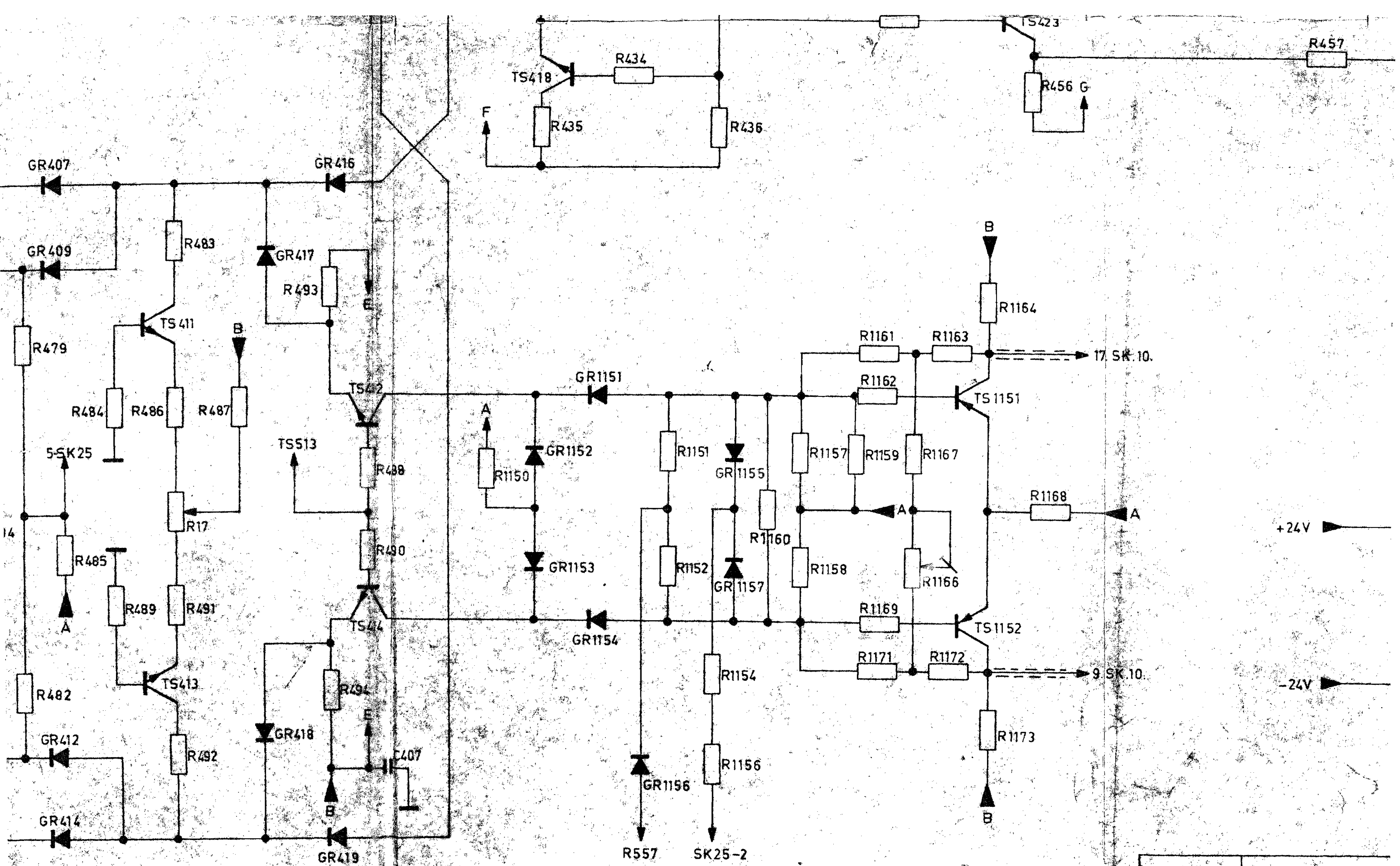

		TUSSEN VERST	
NAAM	C. MULDER	WERK	VERV.
NO		N.V. PHILIPS' GLOEIAMPENFABRIEK	

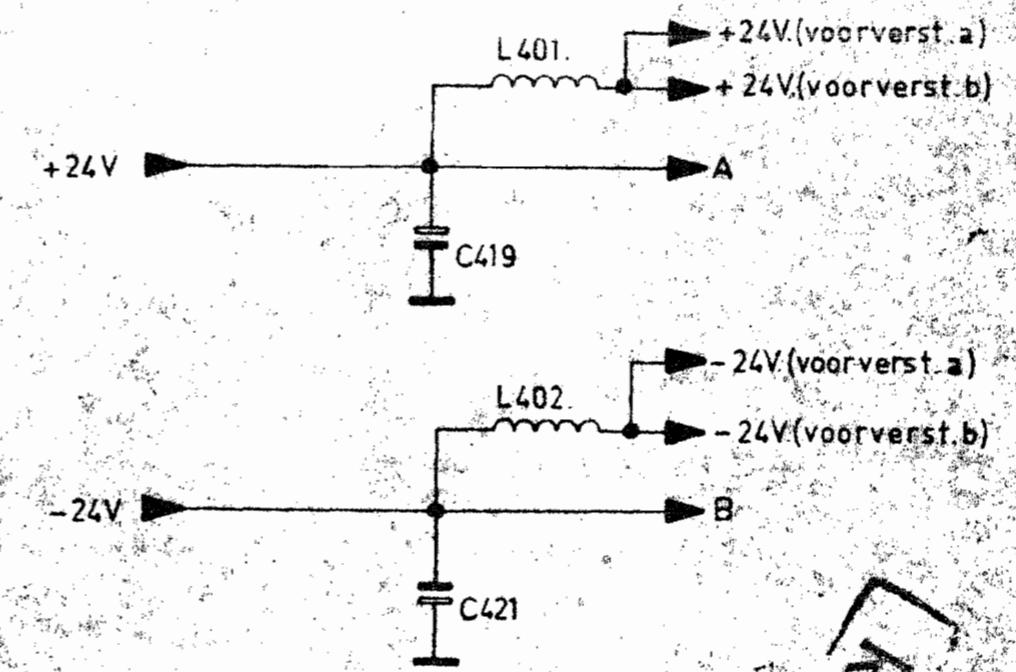
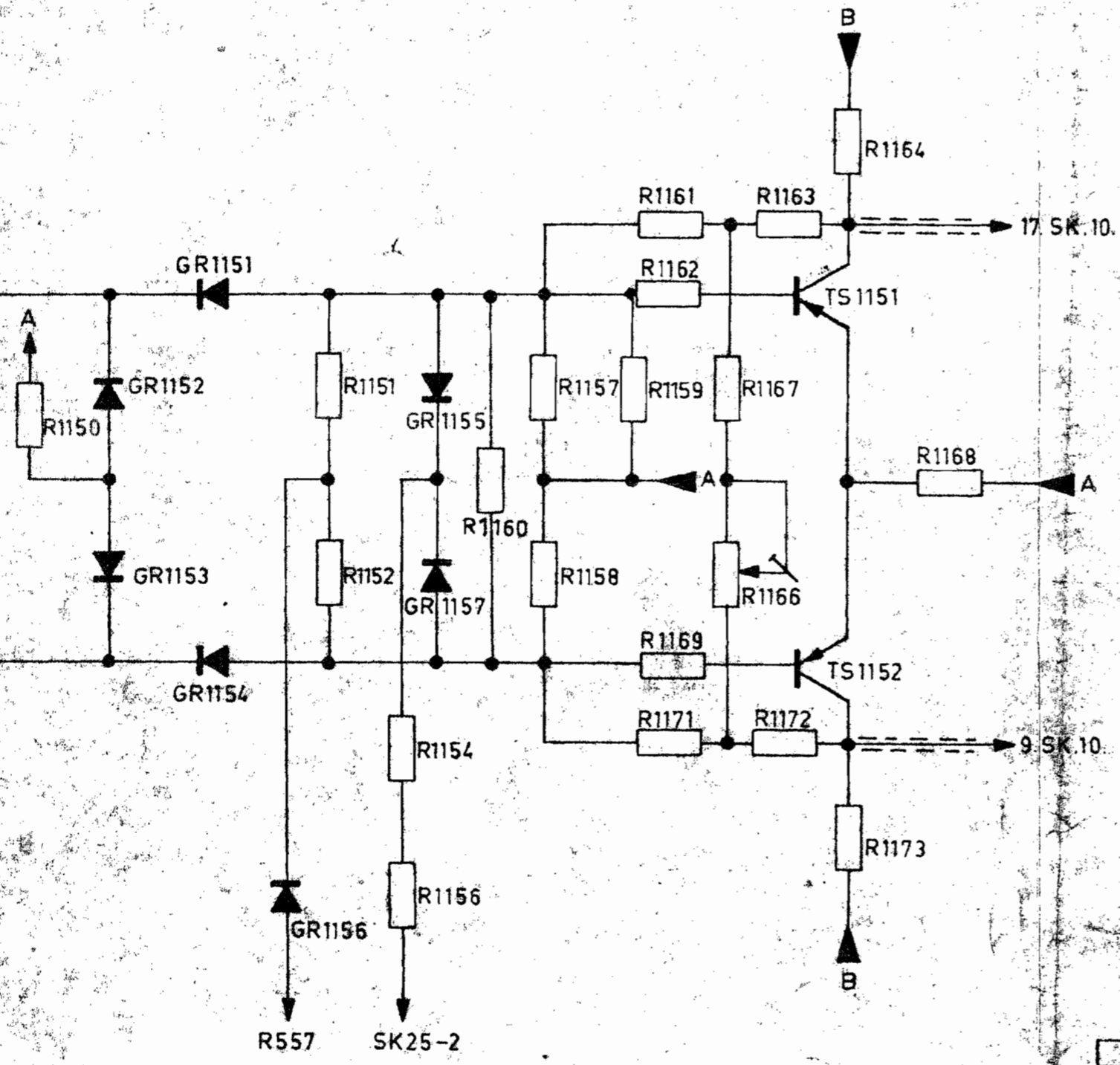
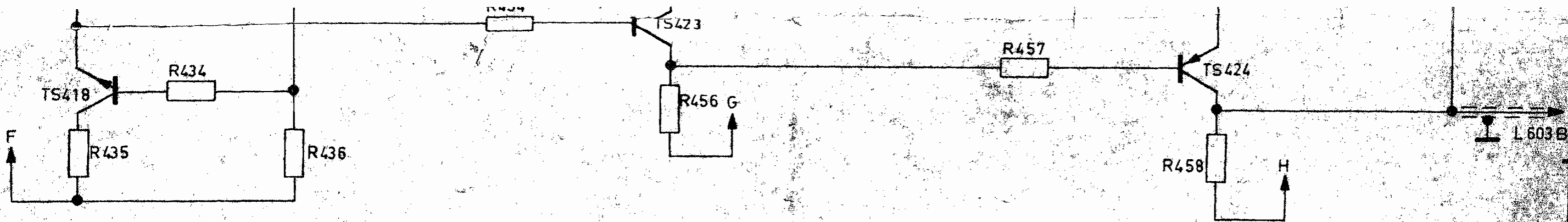

Res. A

TUSSEN VERSTERKER.		9444 032 50031	30-09-69
		PM 3250/03	30-10-69
			22-12-69
			11-2-70
NAAM C. MULDER	NUMM. 130 - 5	DAT. 02-09-69	
N.V. PHILIPS' GLOEI LAMPENFABRIEKEN EINDHOVEN - NEDERLAND		FORM. A1	

WIDERSTAND

0.1W

ALLE DIODEN SIND BAX 13

R14  
(U14)

R1601  
0.150

BFY90

TS1601

GR1601

C1601

R1603

C1608

BC 109

TS1602

R1608  
0.560

R1609  
1k0

R1602

R1611

R1612

C1602  
22K

GR1603

GR1604

R1617  
1k2

+12V

R1616  
0.150

BFY90

TS1603

R1613  
4k3

GR1606

C1605  
22K

+12V

C1607

BFY90

TS1604

R1621  
0.56

R1623

GR1605

R1619  
0.72

+12V

R1604  
27k

R1606  
27k

R1607

R1605  
1k2

C1603  
22K

R1614  
27k

C1604

GR1607

+12V

R1622  
5k6

R1623

C4.5

R411  
0.100

BC 109

TS403

R412

R413

R414

R416

R417

R418

R419

R420

R421

R422

R423

R424

R425

R426

R427

R428

R429

R430

R431

R432

R433

R434

R435

R436

R437

R438

R439

R440

R441

R442

R443

R444

R445

R446

R447

R448

R449

R450

GR401

GR402

BSX20

TS407

R420

R421

R422

R423

R424

R425

R426

R427

R428

R429

R430

R431

R432

R433

R434

R435

R436

R437

R438

R439

R440

R441

R442

R443

R444

R445

R446

R447

R448

R449

R450

+12V

L20

+12V

L20

+12V

L20

+12V

L20

+12V

L20

+12V

L20

+12V

L20

+12V

L20

+12V

L20

+12V

L20

+12V

L20

+12V

L20

+12V

L20

+12V

L20

+12V

L20

+12V

L20

+12V

L20

+12V

L20

+12V

L20

+12V

L20

(U11)

RE501

GR1608

SK20

CLOSED

IN POS

1

2

3

4

5

6

R1613

GR503

GR518

GR500

GR1609

GR1611

RE502

1

2

3

4

R1604

GR503

GR518

GR500

GR1609

GR1611

RE502

1

2

3

4

R1604

GR503

GR518

GR500

GR1609

GR1611

RE502

1

2

3

4

+12V

GR1612

GR1612

GR1612

GR1612

GR1612

GR1612

GR1612

GR1612

GR1612

GR1612

+12V

GR1612

GR1612

GR1612

GR1612

GR1612

GR1612

GR1612

GR1612

GR1612

GR1612

+12V

GR1612

GR1612

GR1612

GR1612

GR1612

GR1612

GR1612

GR1612

GR1612

GR1612

+12V

GR1612

GR1612

GR1612

GR1612

GR1612

GR1612

GR1612

GR1612

GR1612

GR1612

+12V

GR1612

GR1612

GR1612

GR1612

GR1612

GR1612

GR1612

GR1612

GR1612

GR1612

+12V

GR1612

GR1612

GR1612

GR1612

GR1612

GR1612

GR1612

GR1612

GR1612

GR1612

+12V

GR1612

GR1612

GR1612

GR1612

GR1612

GR1612

GR1612

GR1612

GR1612

GR1612

+12V

GR1612

GR1612

GR1612

GR1612

GR1612

GR1612

GR1612

GR1612

GR1612

GR1612

+12V

GR1612

GR1612

GR1612

GR1612

GR1612

GR1612

GR1612

GR1612

GR1612

GR1612

R15

(U14)

1

2

3

4

5

6

7

8

9

10

11

12

13

14

15

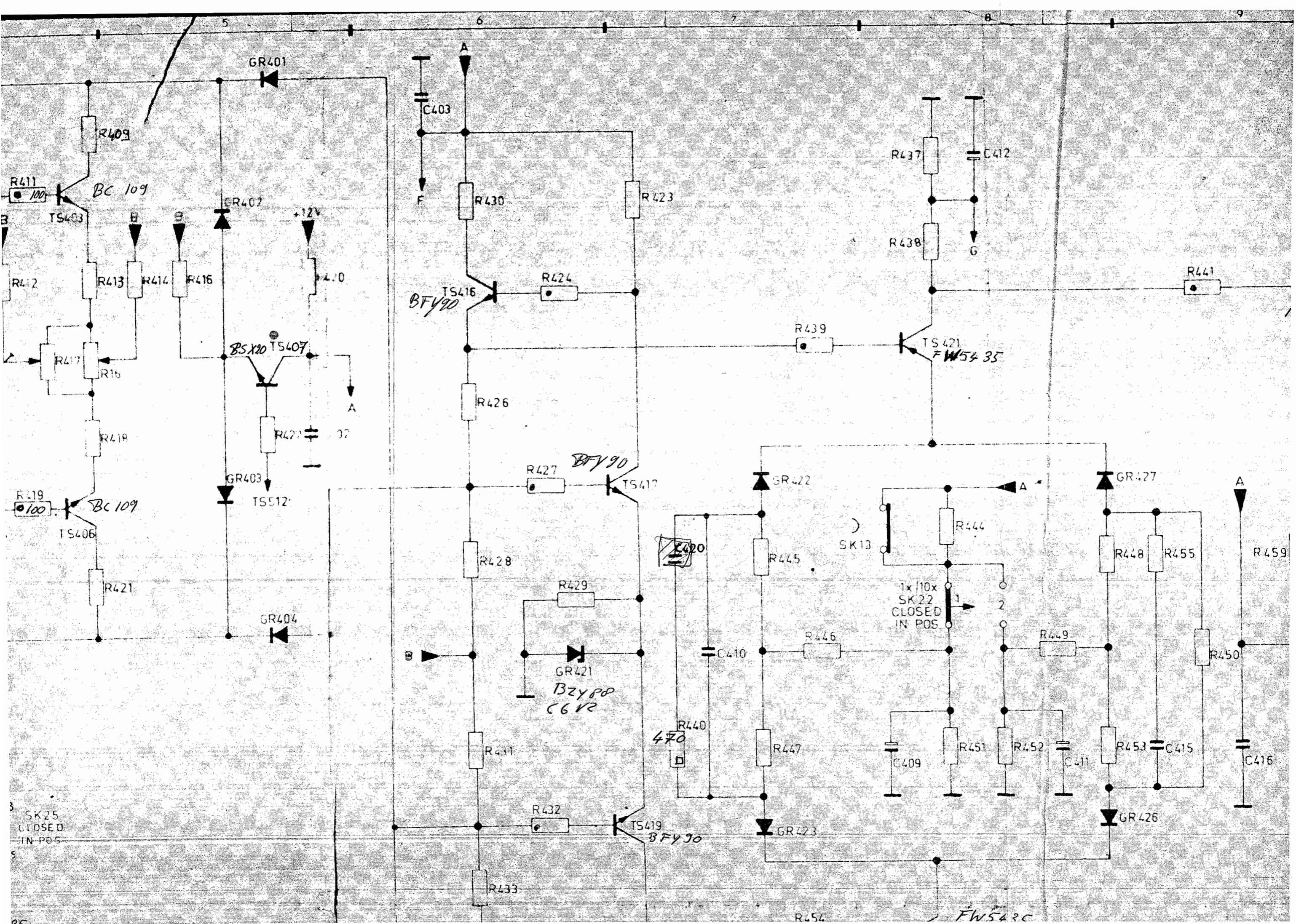

GR401

GR402

GR403

GR404

A

F

R437

C412

R438

G

R441

TS421

FW5435

TS416

BFY90

R424

R439

R426

R427

BFY90

TS417

SR422

GR427

R428

R429

GR421

BZY88

6.1V

R440

470

R445

SK13

1x10x

SK22

CLOSED

IN POS

R446

C410

R449

R448

R455

R459

R431

R432

TS419

BFY90

GR423

GR426

R433

R454

FW543C

R411

BC109

TS403

R412

R413

R414

R416

BSX10

TS407

R418

R419

BC109

TS406

R421

SK25

CLOSED

IN POS

25

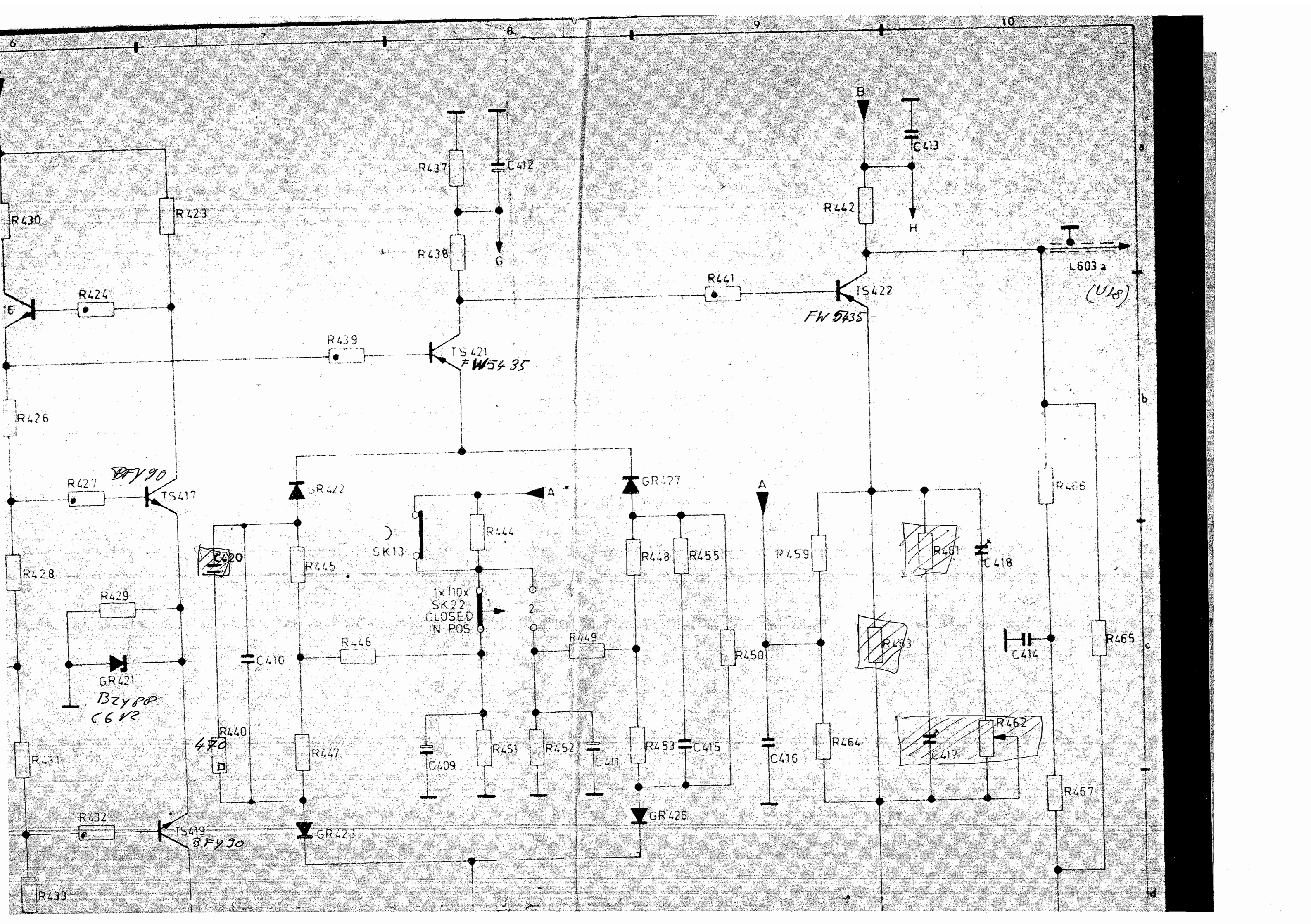

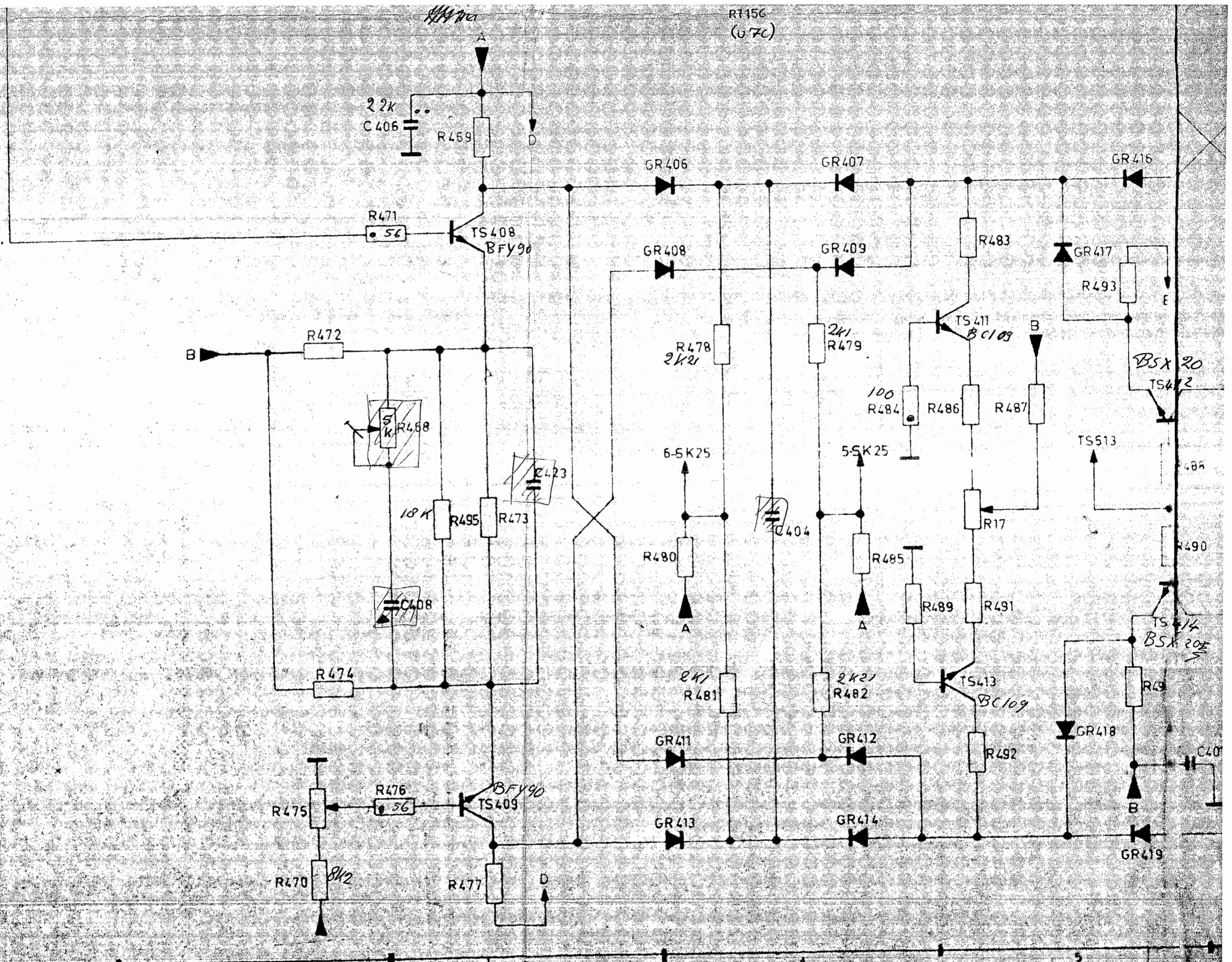

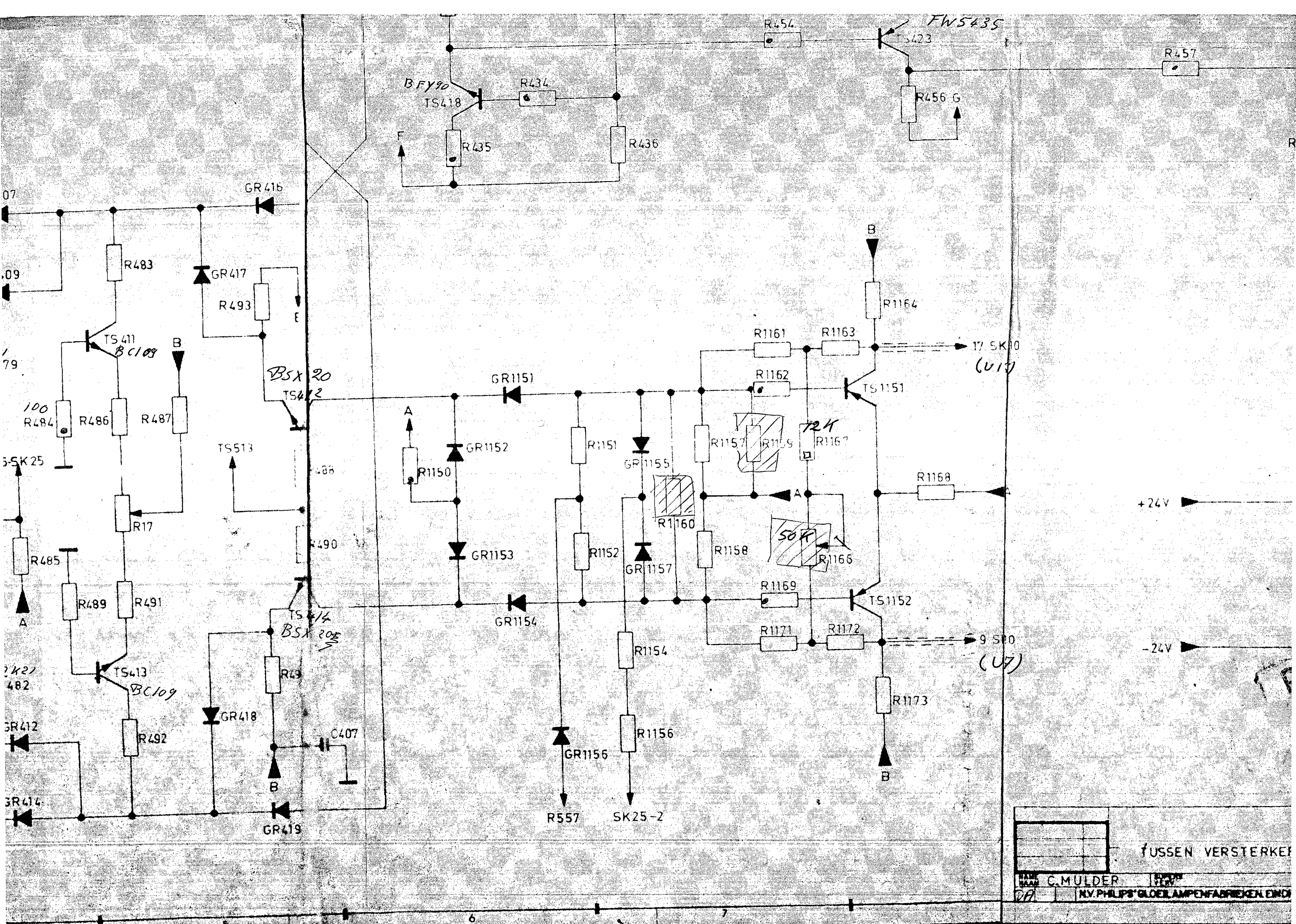

TUSSEN VERSTERKER  
 C. MULDER  
 N.V. PHILIPS' GLOEI-LAMPEN-FABRIEK EINDHOVEN

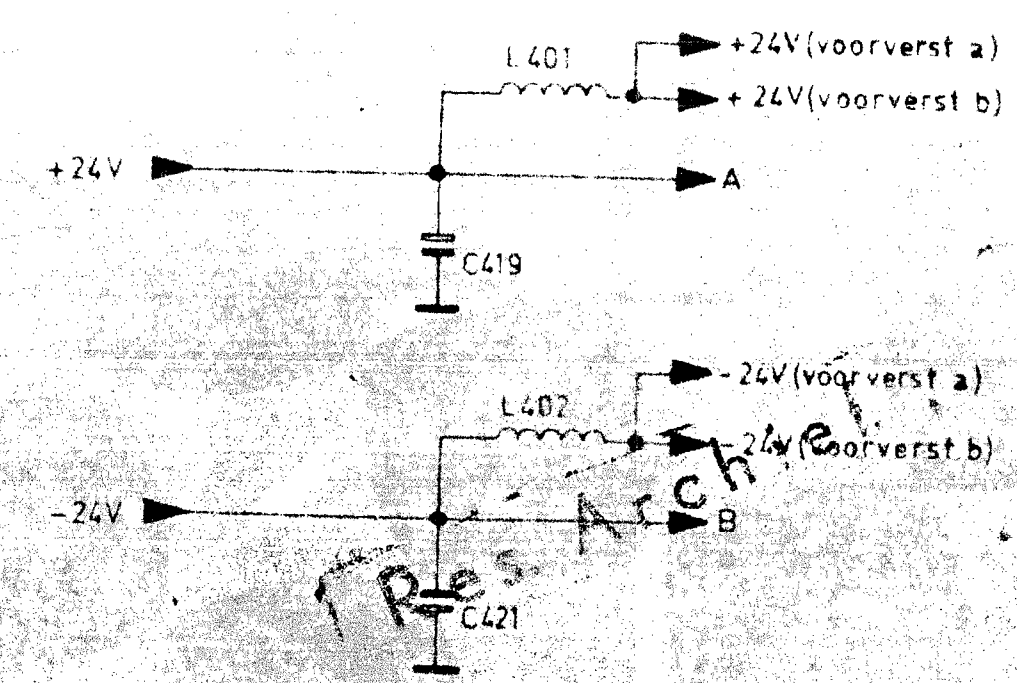
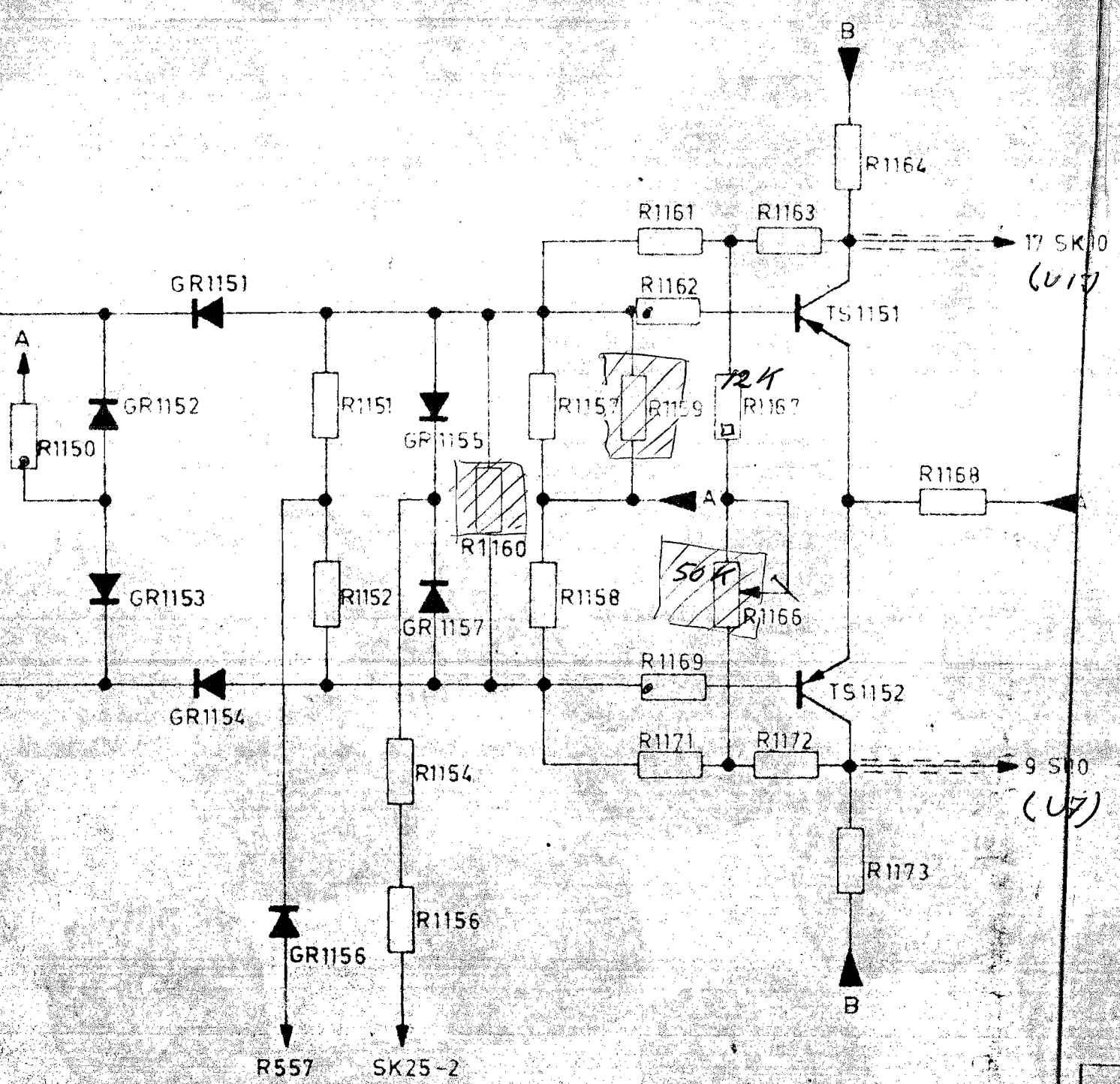
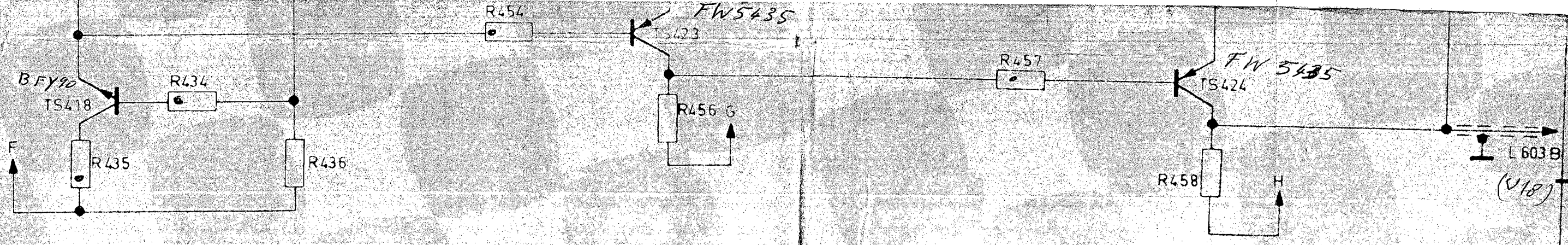

TUSSEN VERSTERKER		9444 032 50031	30-09-69
		PM 3250/03	30-10-69
			22-12-69
			11-2-70
			25-8-70
NAME G. MULDER	CONTR.	14 130 - 5	DATE 02-09-69
NV. PHILIPS' GLOEIAMPENFABRIEKEN, EINDHOVEN - NEDERLAND			FORM. A1





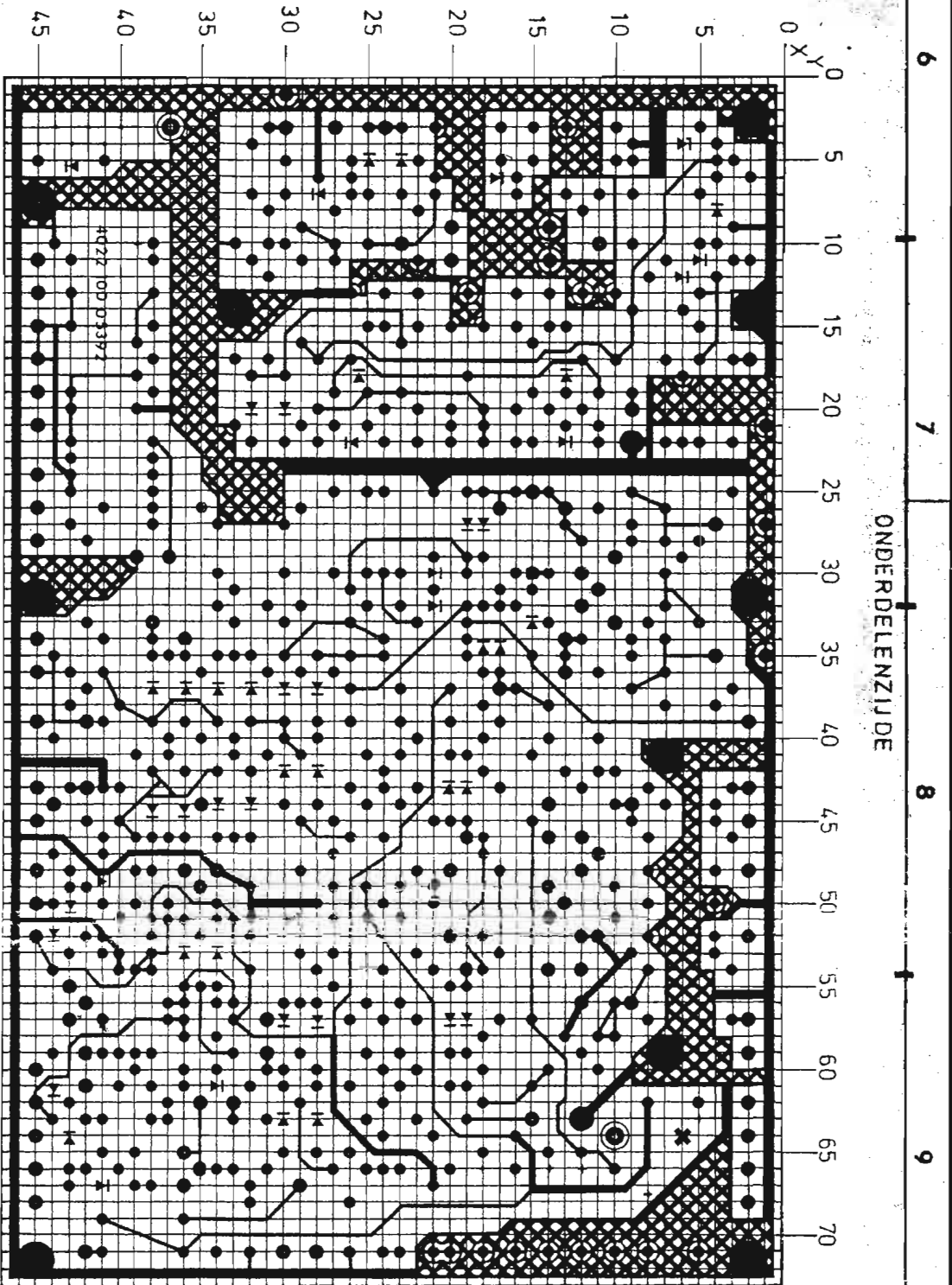

ONDERDELENLIJDE

185,42 ± 0,5

162,56 ± 0,5

25,40 ± 0,5

119,38 ± 0,5

REF. GAT

REF. GAT

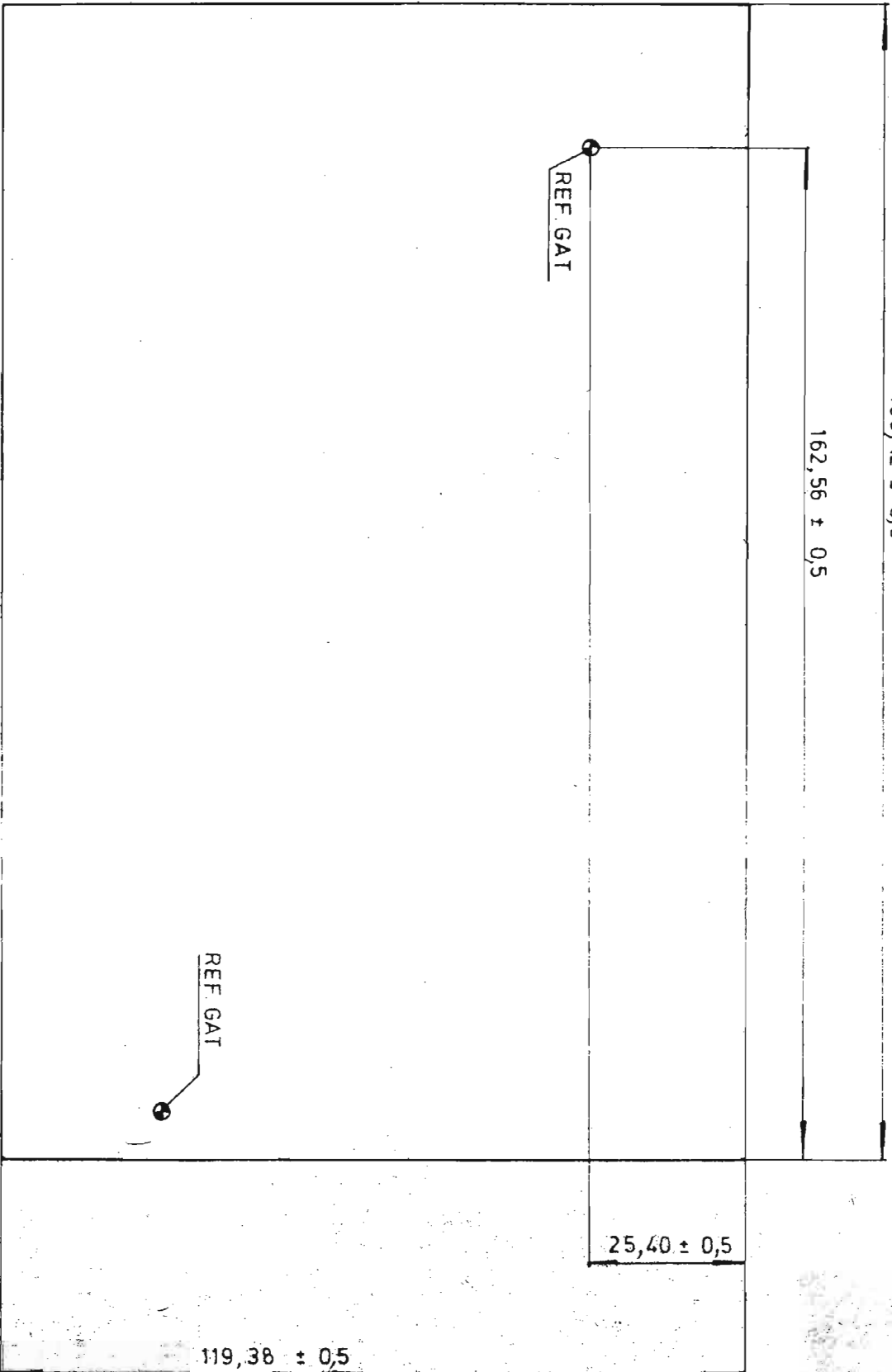

<p>UN-D 28</p> <p>TOLERANCES UNLESS OTHERWISE STATED TOLERANTIES TENZI ANDERS VERMELD</p>		<p>UN-D 603</p>	
<p>GENERAL NOTICES ALGEMEEN RUMMELD</p>	<p>UNIT EENH. MM</p>	<p>MATERIAL MATERIAAL</p>	<p>ASSEMBLY NO. SAMENSTELLINGS NR.</p>
<p>SCALE SCHIJAAL 1:1</p>	<p>PROJ. EUROPE TREATMENT BEHANDELING</p>	<p>MICAPLY I OXY GLW. PL. 35 μ Cu 0822 114 01071</p>	<p>PATTERN NO. MODEL NR.</p>
<p>CLASS NO.</p>	<p>SPOREN + LATEN VERSOLDEREN DOORMEALISEREN vlg. Icomd spec PRR 22-4-60</p>	<p>ORDER NO. / COHM. NR.</p>	<p>QUANT. AANT.</p>
<p>NAME I. MANDERS</p>		<p>PANEEL</p>	
<p>PM 3250</p>		<p>4022 100 0539</p>	
<p>PROPERTY OF NV PHILIPS GLOELIJP-FABRIEKEN EINDHOVEN-NEDERLAND</p>		<p>pat. 19-11-69</p>	
<p>FORM A2</p>		<p>pat. 19-11-69</p>	
<p>pat. 19-11-69</p>		<p>pat. 19-11-69</p>	

CALQUE

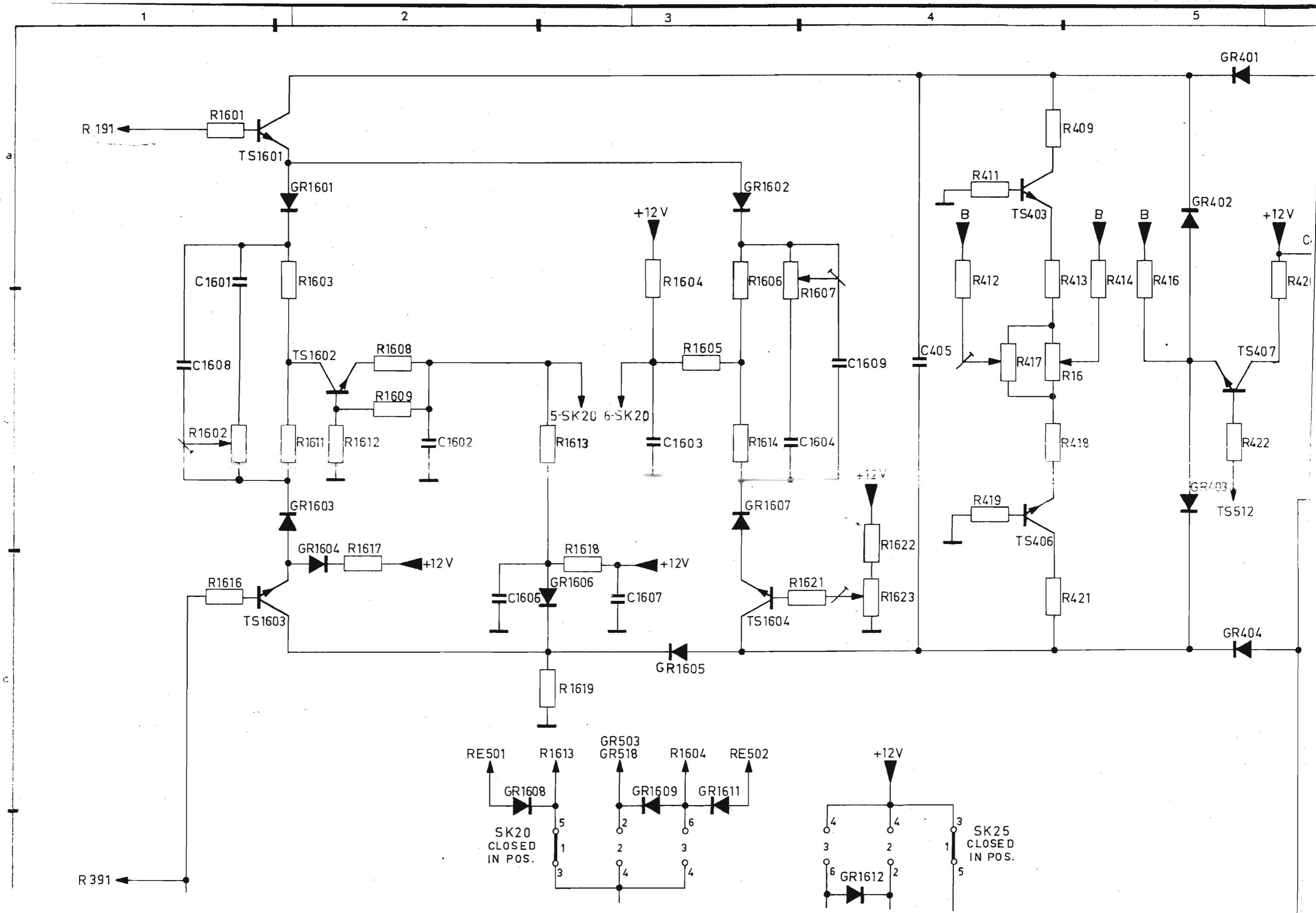

R391

-12V

R480

GR507  
R1156

R485

C406

R469

D

GR406

GR407

GR416

R471

TS408

GR408

GR409

R483

GR417

R493

E

R472

B

R478

R479

TS411

R487

TS41

R468

C423

6-SK25

5-SK25

TS513

R495

R473

C404

R480

R485

R484

R486

R487

TS41

C408

R474

R481

R482

R489

R491

TS41

R475

R476

TS409

GR411

GR412

R492

GR418

E

R470

R477

D

GR413

GR414

GR419

-12V

2X102  
 103  
 111  
 126  
 156  
 172  
 175  
 214  
 1265  
 1332  
 44  
 PR

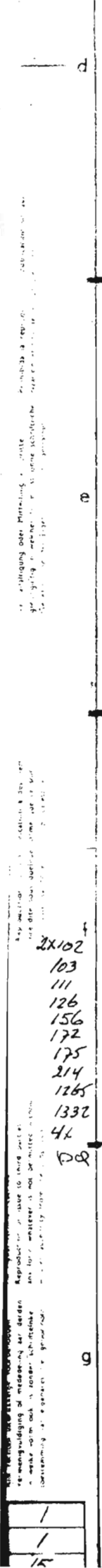

d  
 e  
 f  
 g

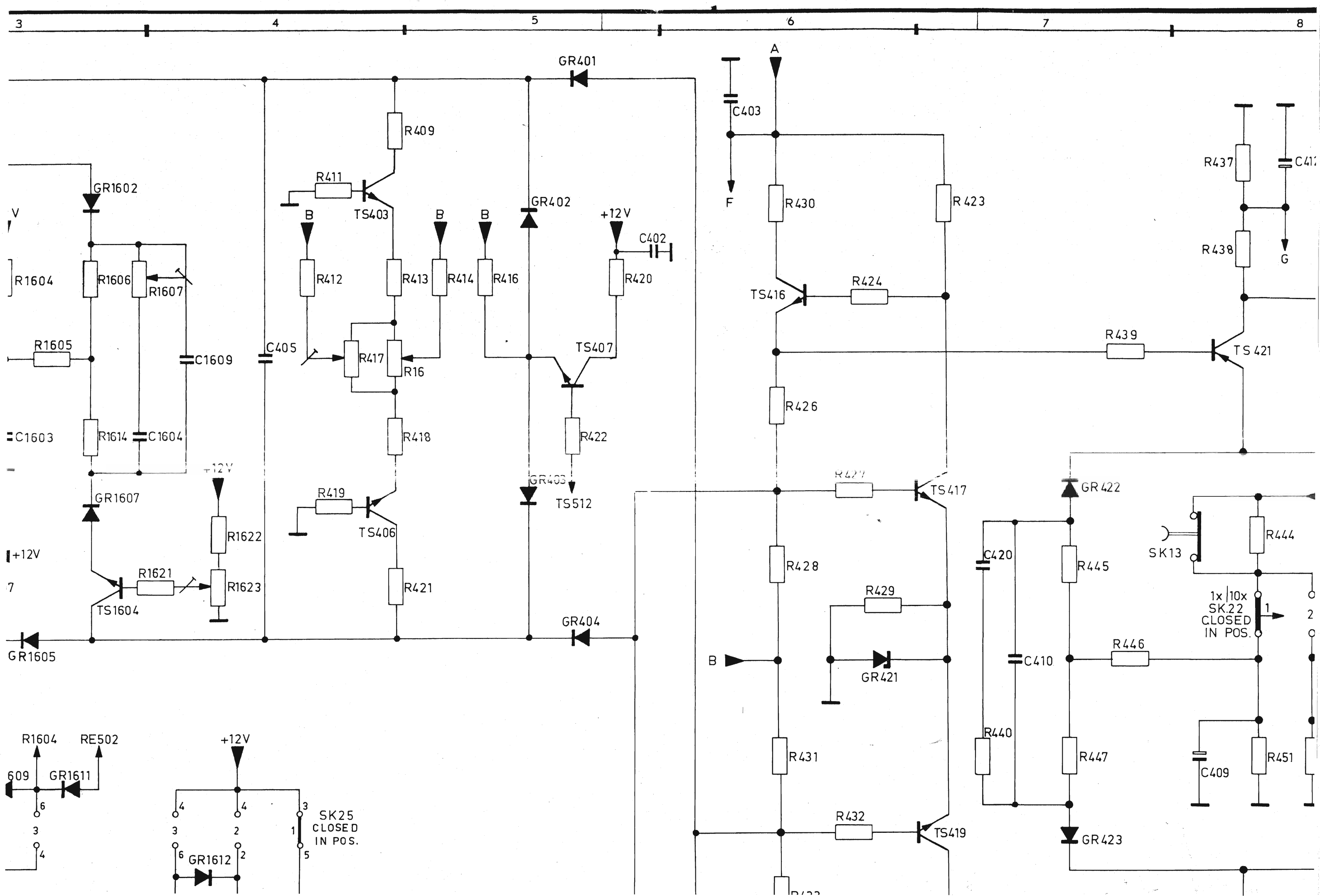

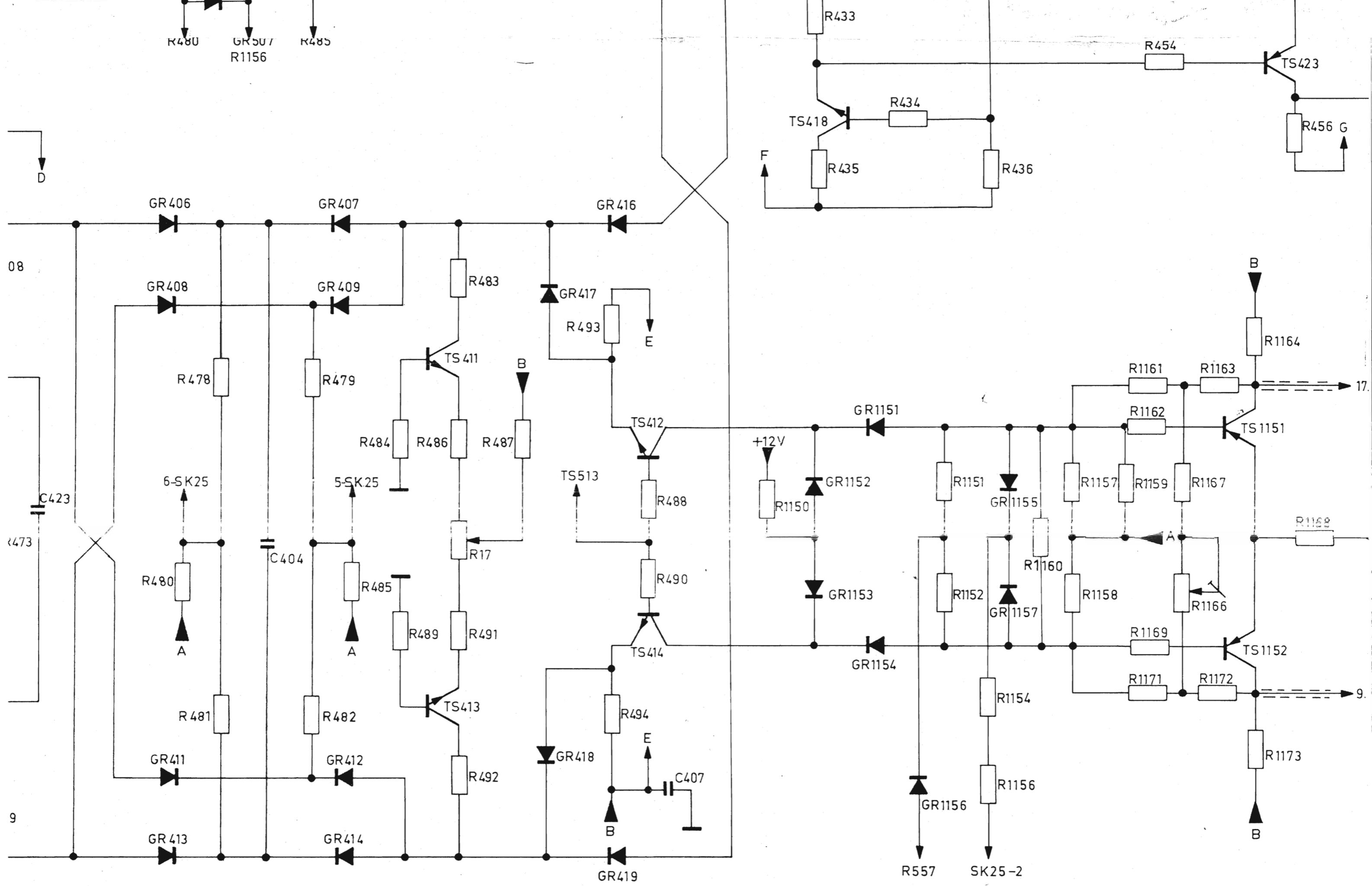

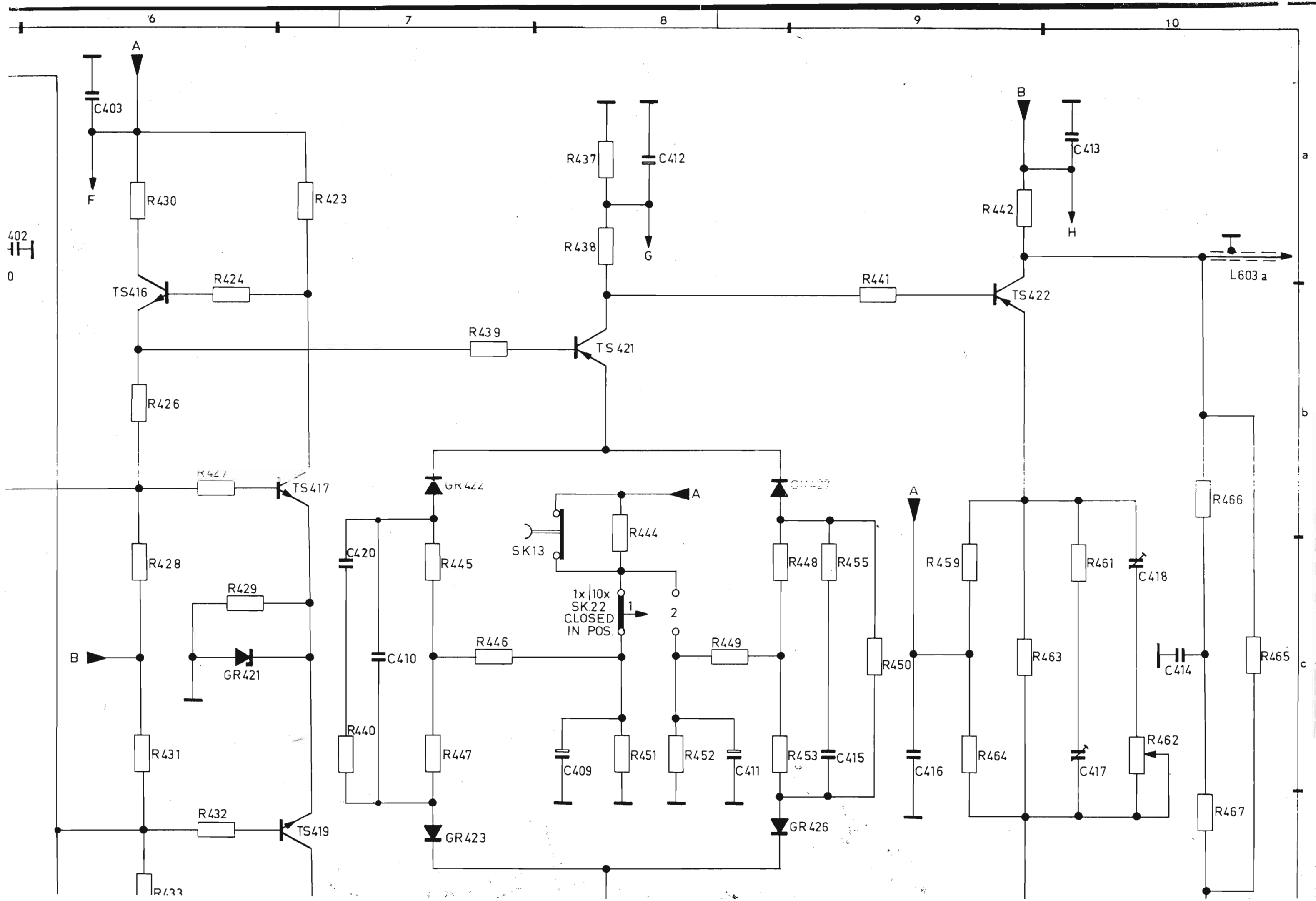

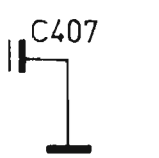
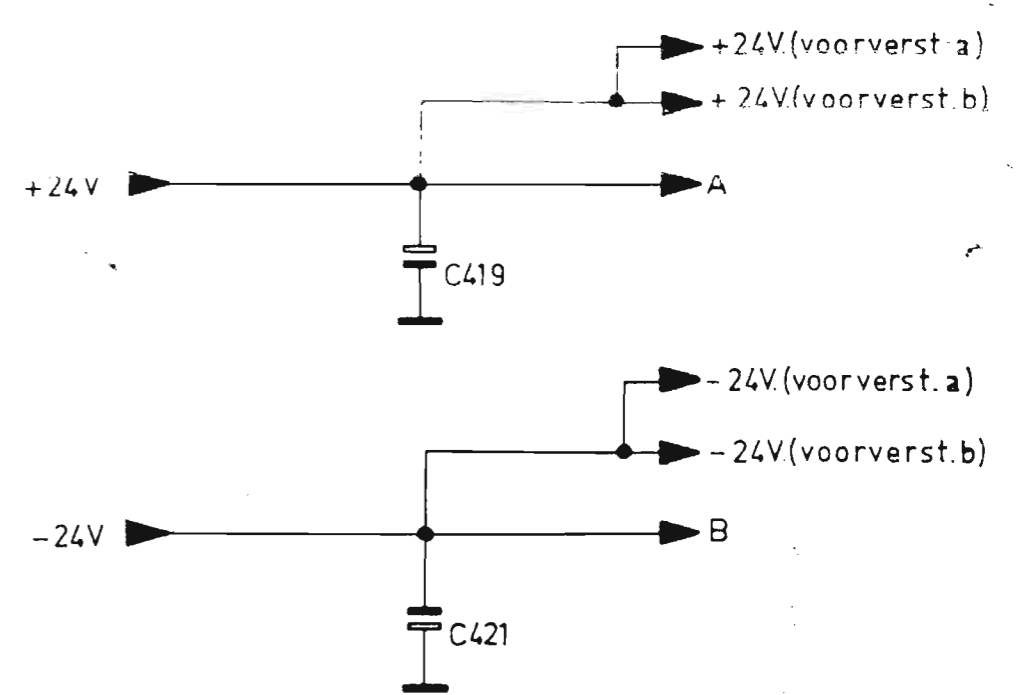
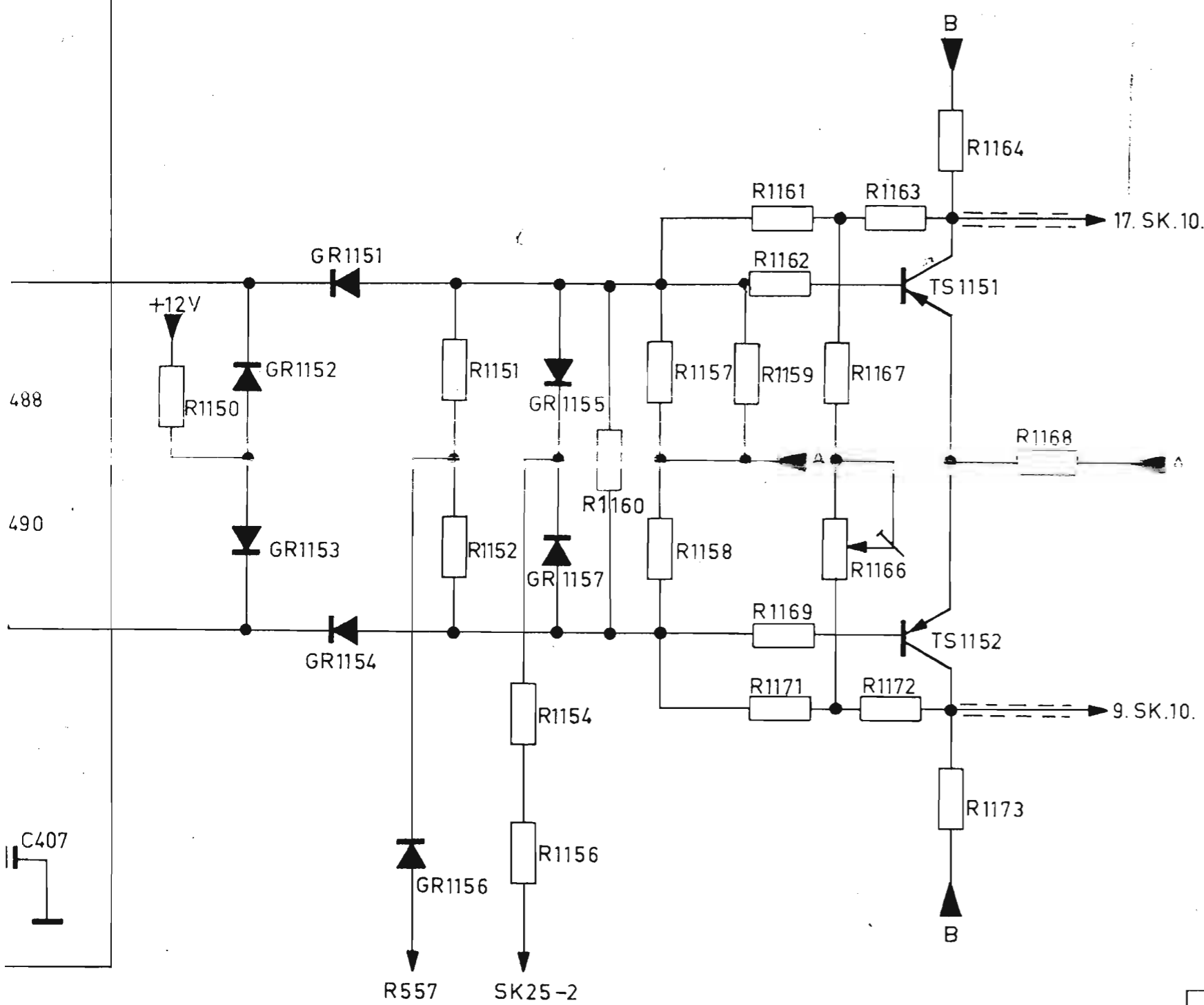
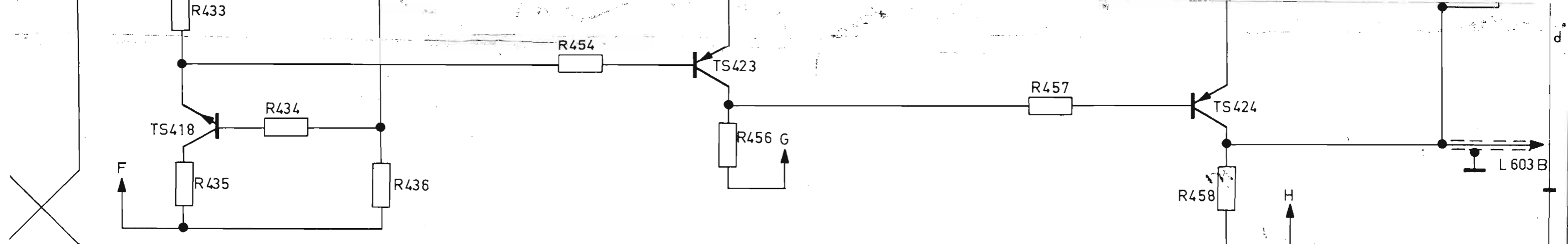



TUSSEN VERSTERKER		9444 032 50031	30-09-69
		PM 3250/03	30-10-69
			22-12-69
			11-2-70
NAME NAAM	C. MULDER	SUPERV. VERV.	14 130 - 5
N.V. PHILIPS' GLOEI LAMPENFABRIEKEN, EINDHOVEN - NEDERLAND		CHECK CONTR.	DAT. 02-09-69 FORM. A1



WIDERSTAND

0.1W

ALLE DIODEN SIND BAX13.

A-B

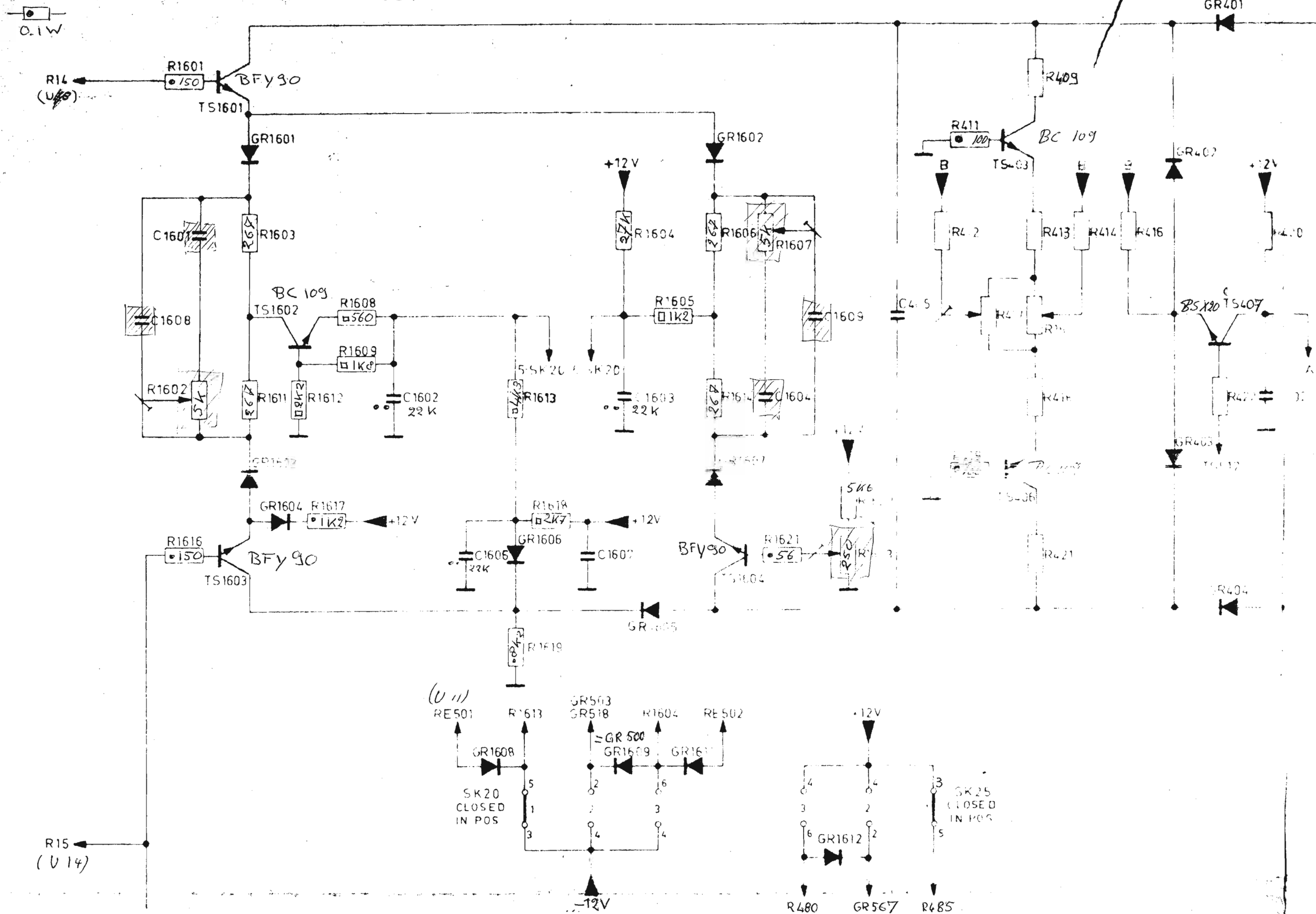

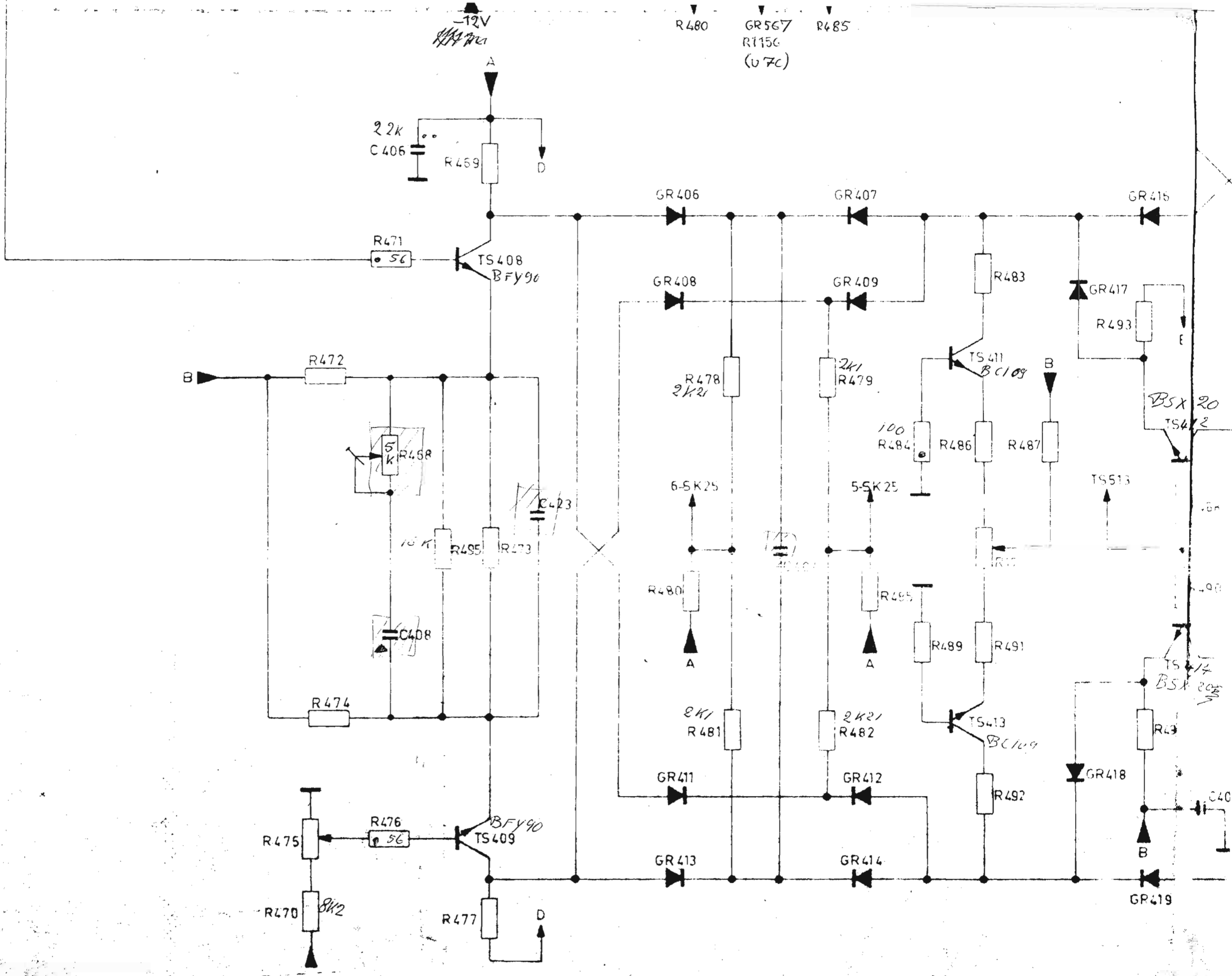



R480 GR567 R485  
R1156  
(U7C)

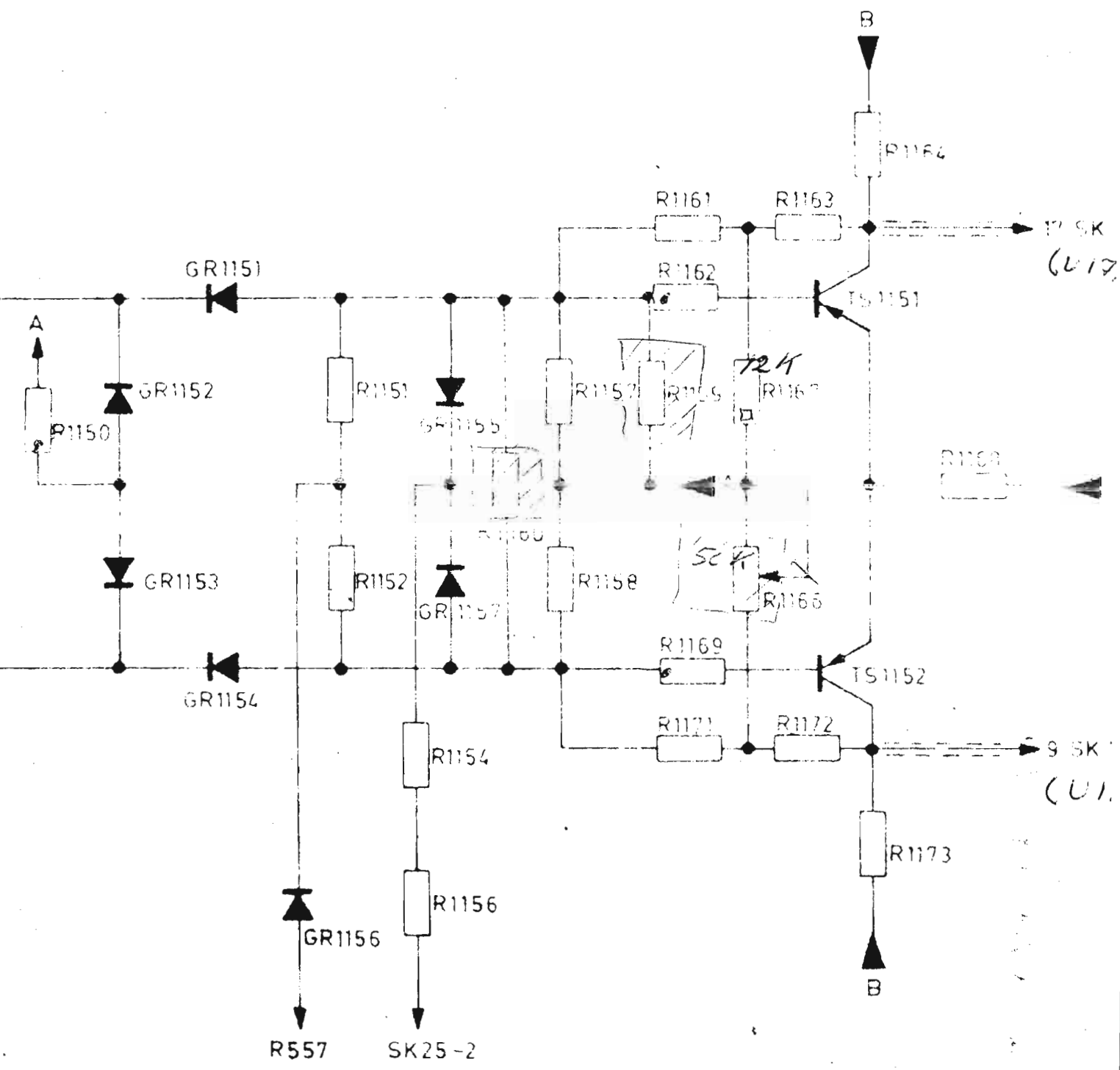
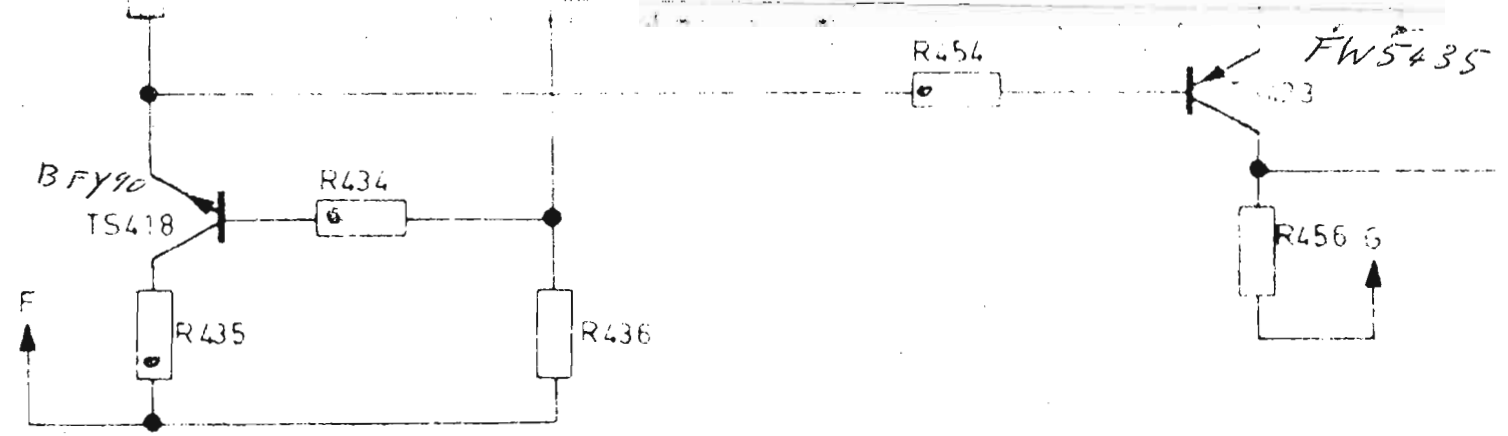
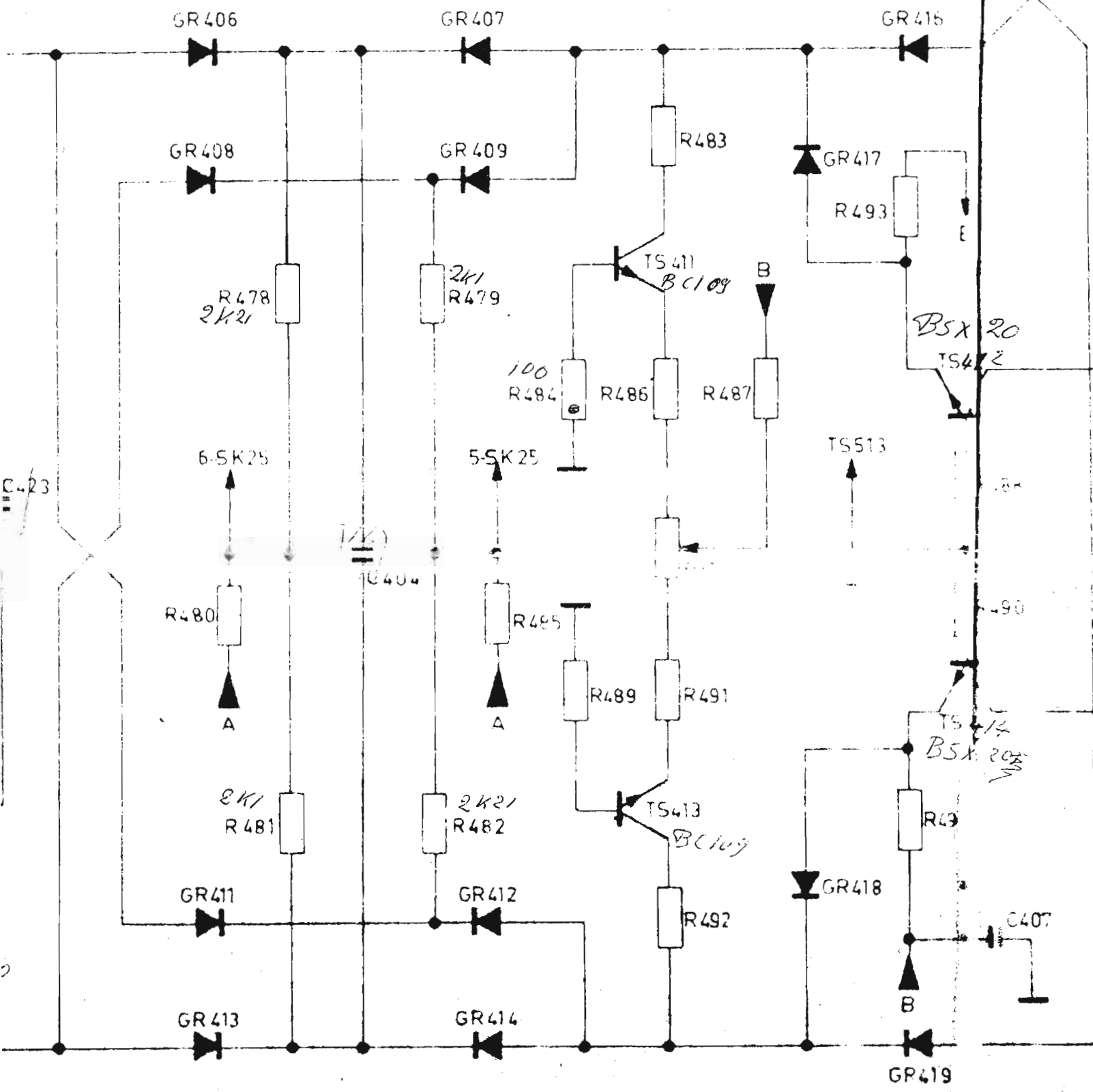

D